

coding  
lab

# RoboMaker<sup>®</sup>

výuková laboratoř robotiky

pro

X5•DROID

Konzultace  
vědeckého kódování  
a blokové  
programování: Prof.  
Alessandro Boqliolo



**PRODUCENT:**  
Clementoni S.p.A.  
Zona Industriale Fontenoce s.n.c.  
62019 Recanati (MC) - Italy Tel.:  
+39 071 75811  
[www.clementoni.com](http://www.clementoni.com)

advanced

Należy przeczytać Instrukcję i zachować ją do wglądu

**Clementoni**

Montáž

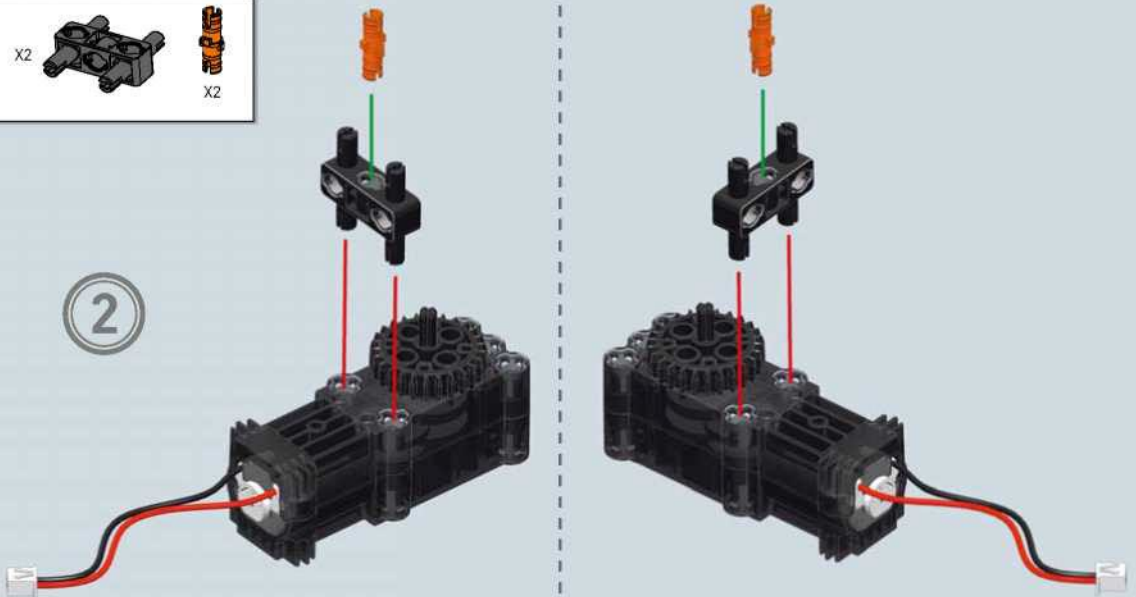
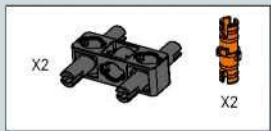
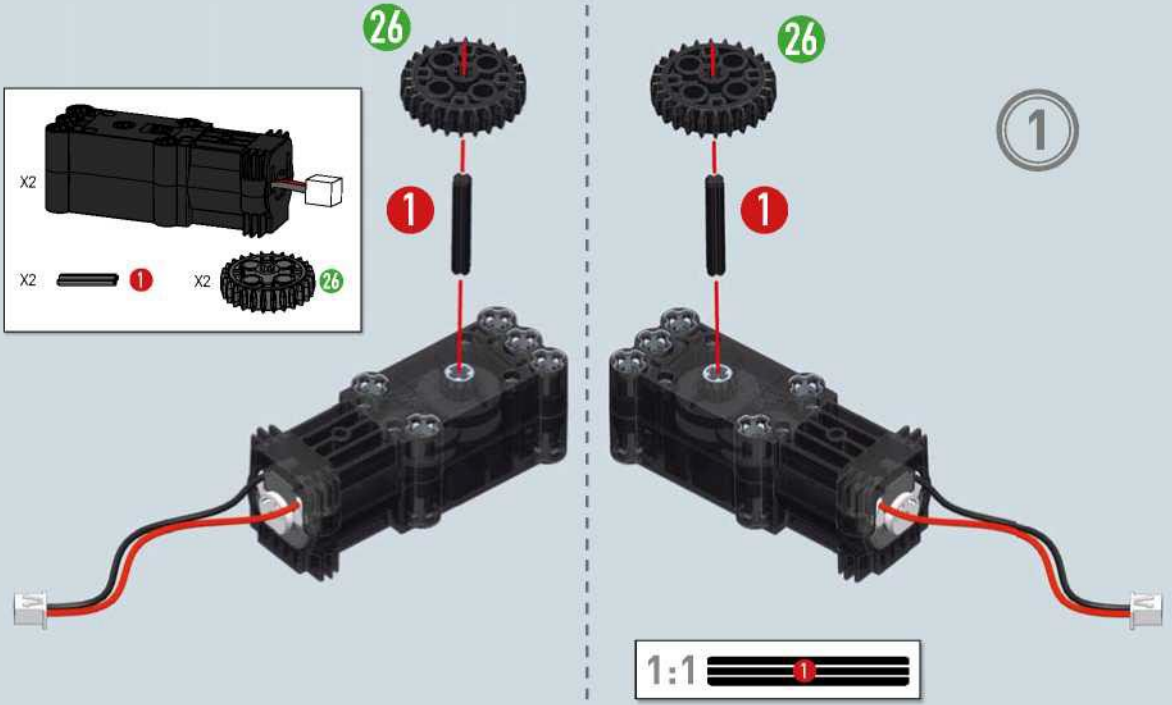

3



10

6

10

6

- X2 6
- X2 10

4

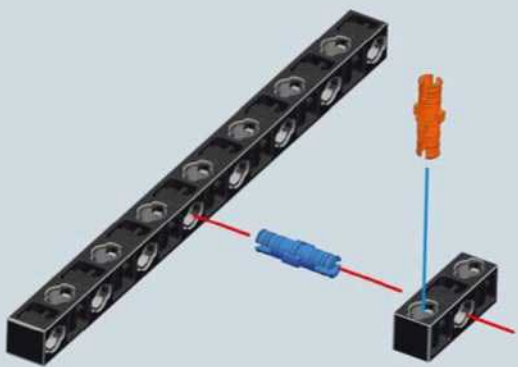
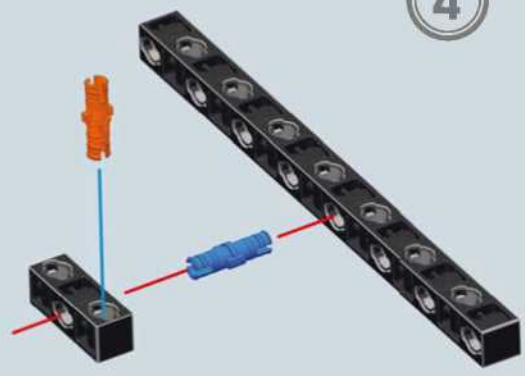

- X2 X2
- X2 6 X2 10 X2 X2



3

5

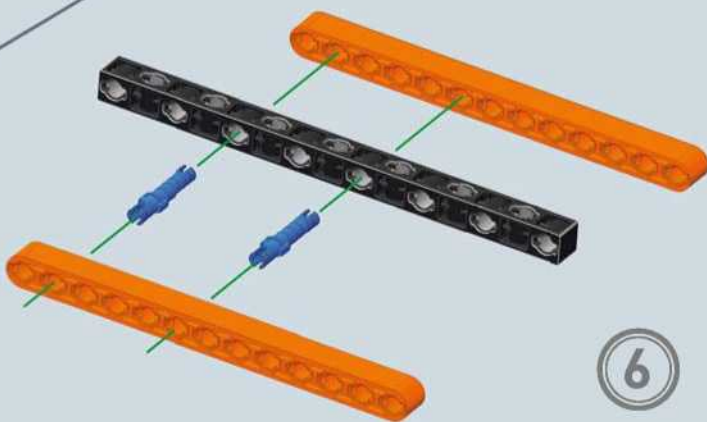
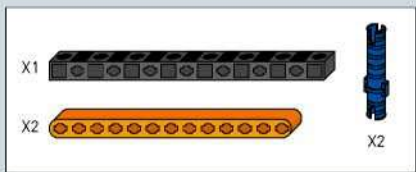

6

7

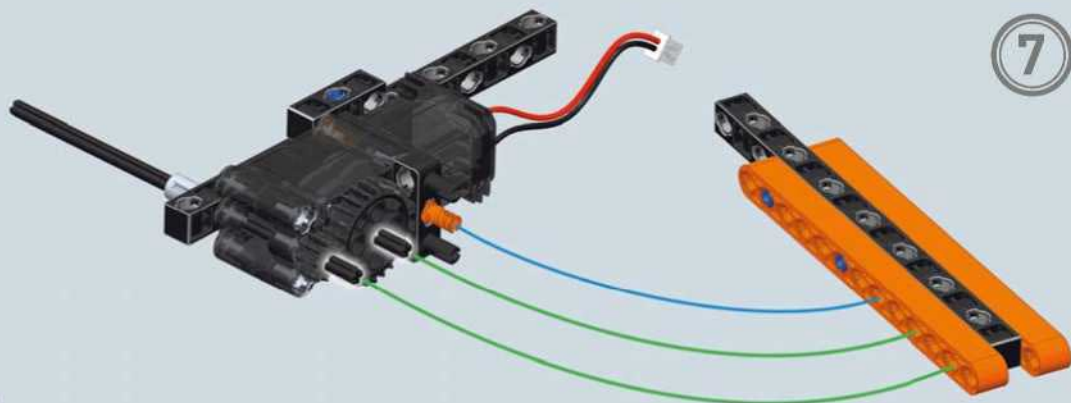

4

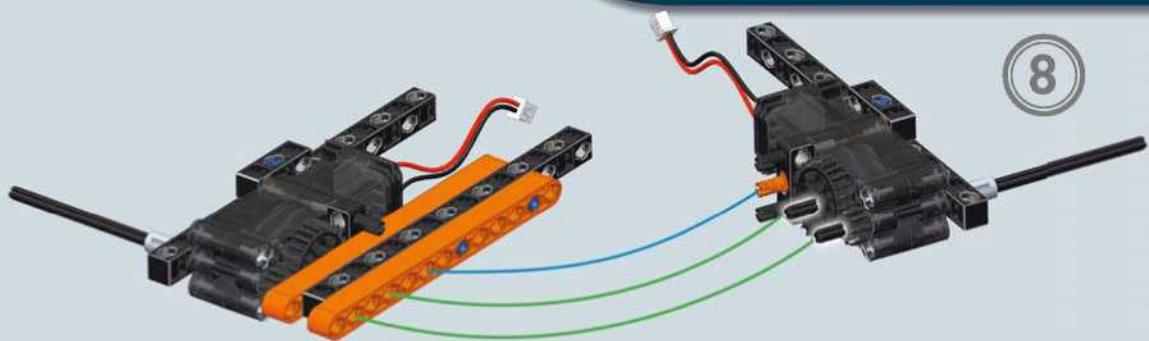

8

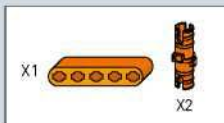
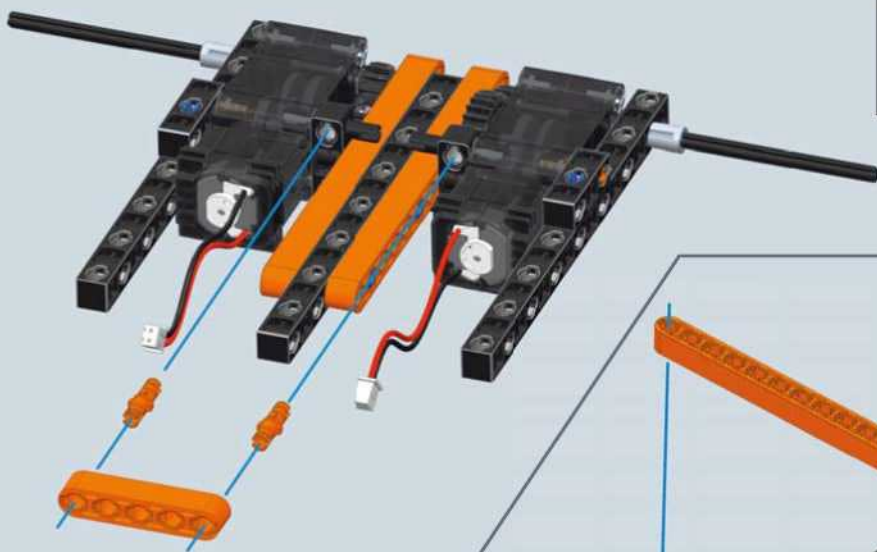

9

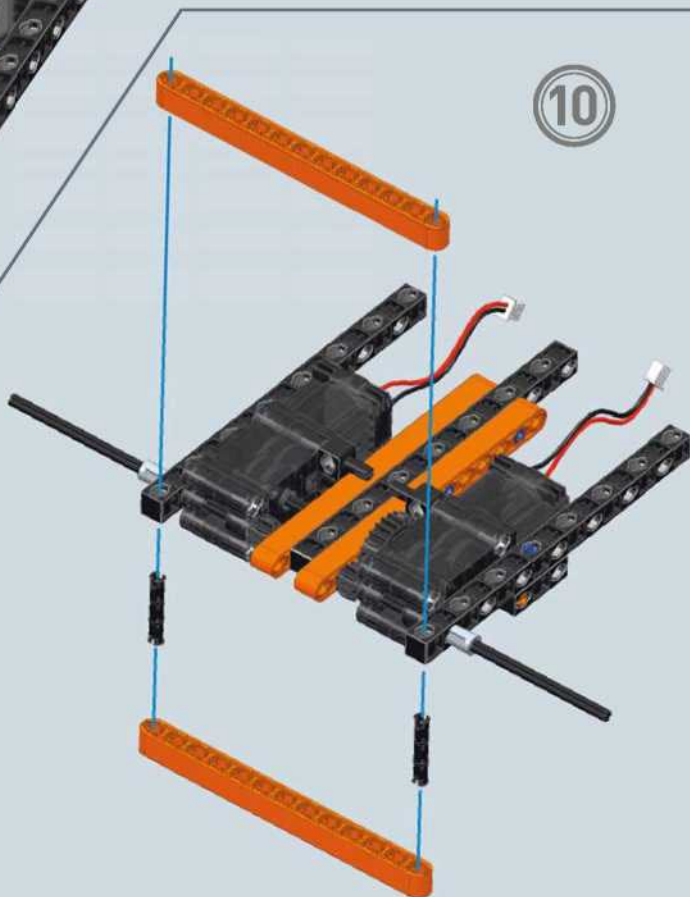

10



12

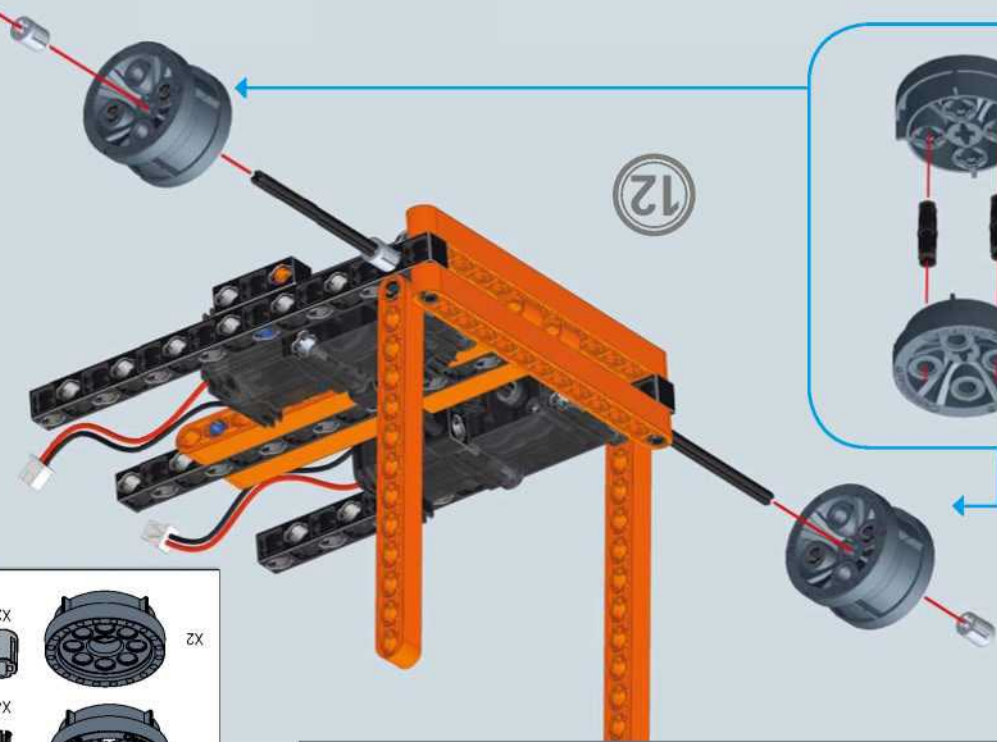
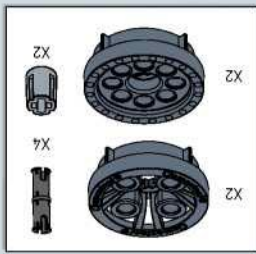
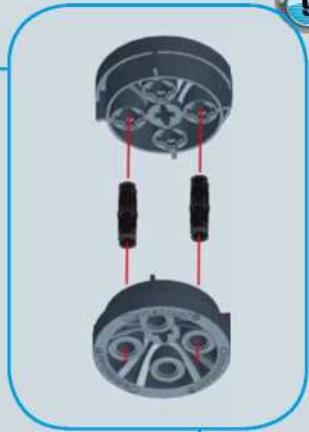

11

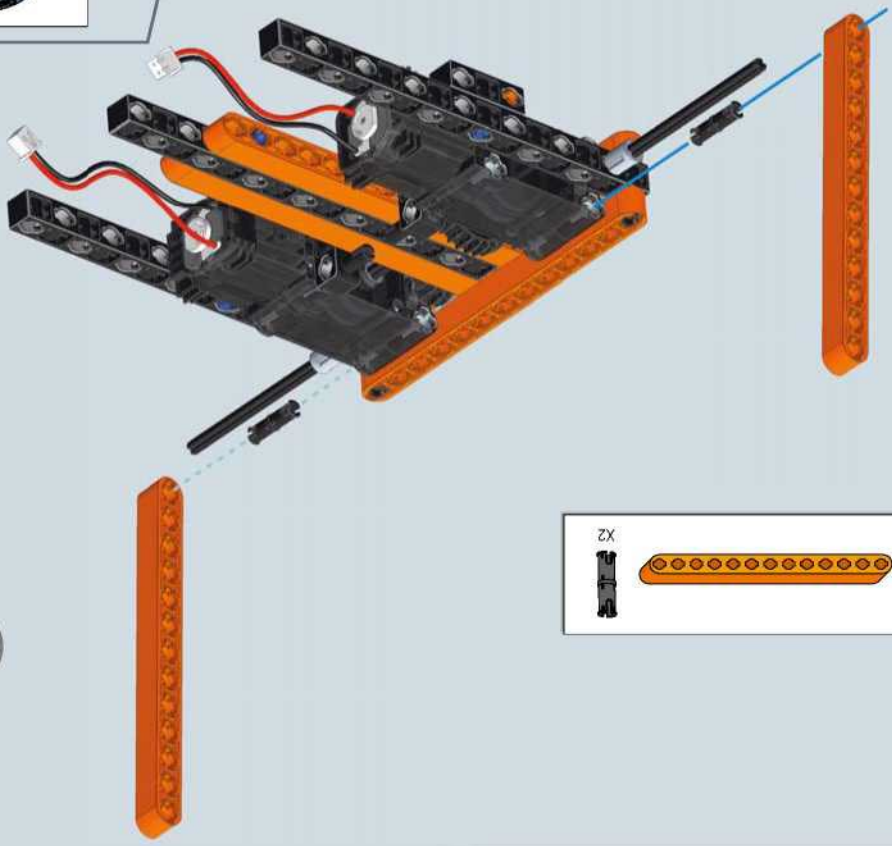

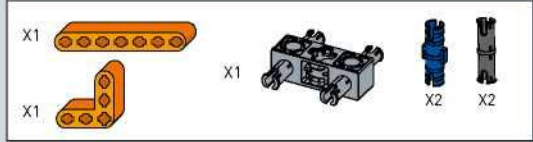
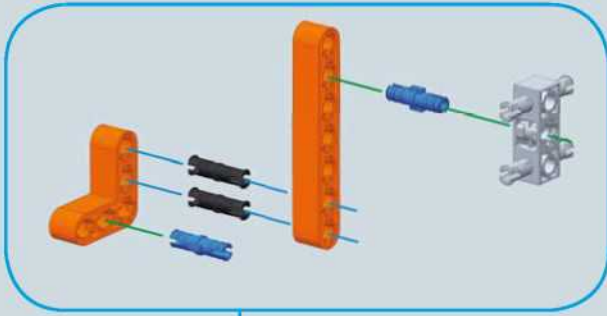

13

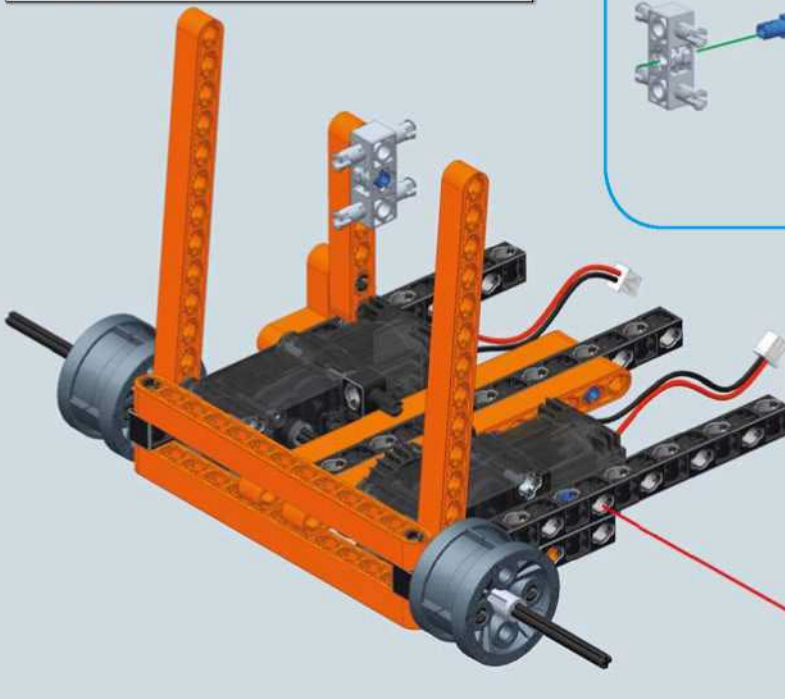
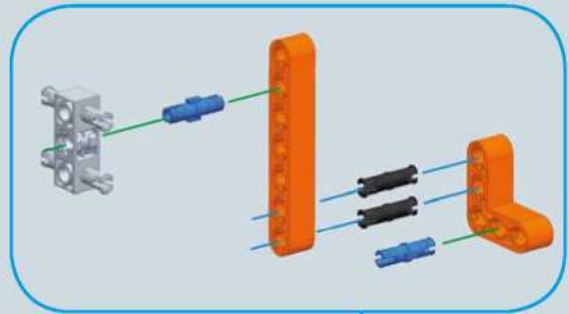
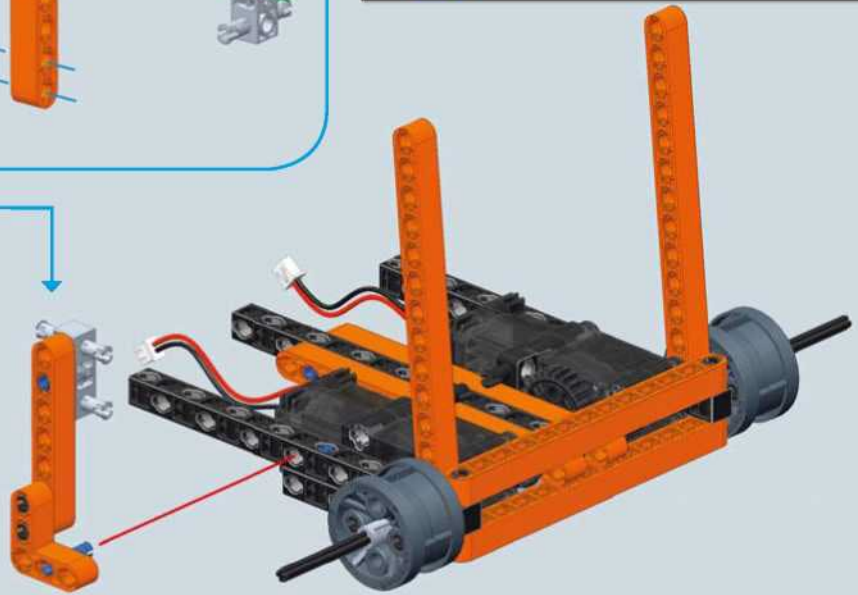

14

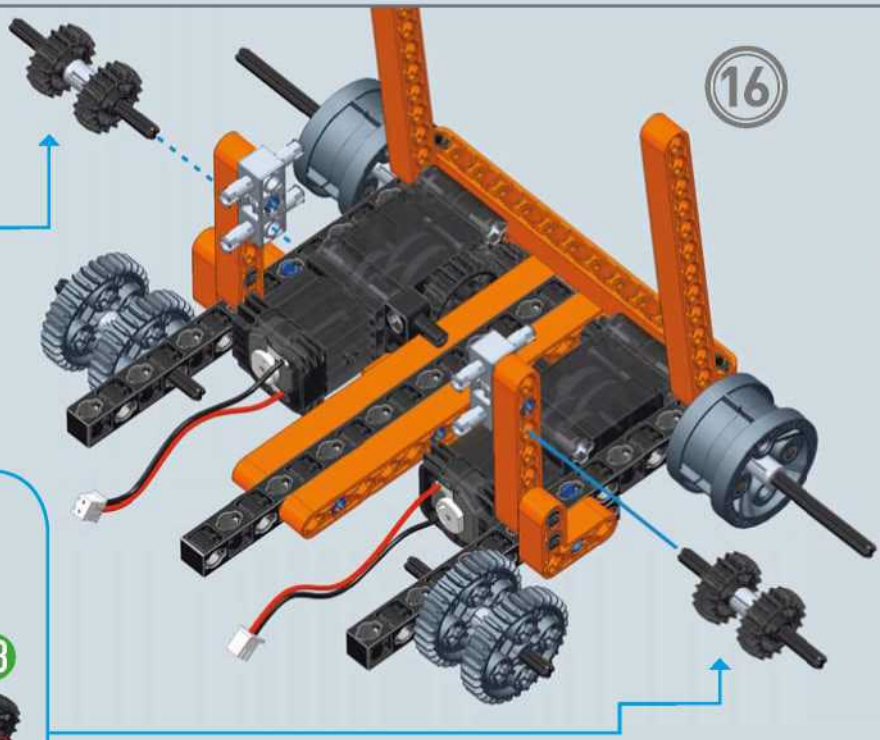
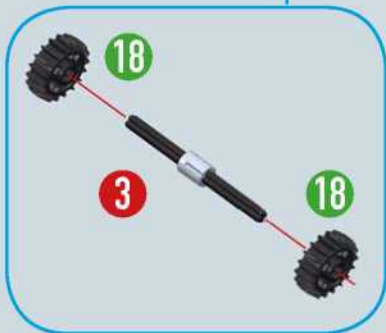
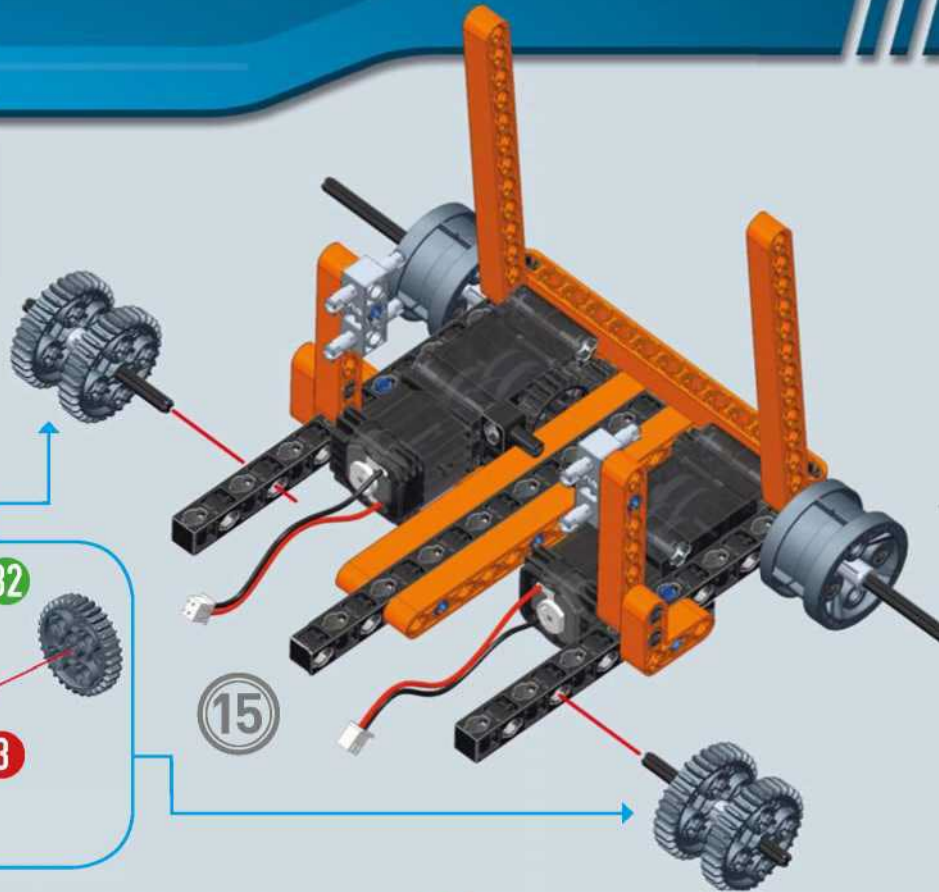
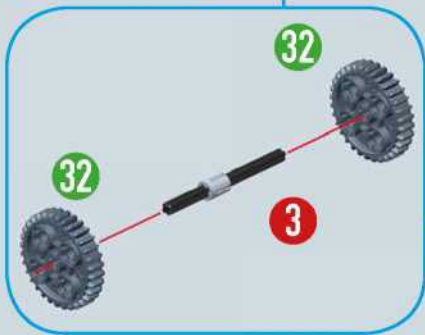



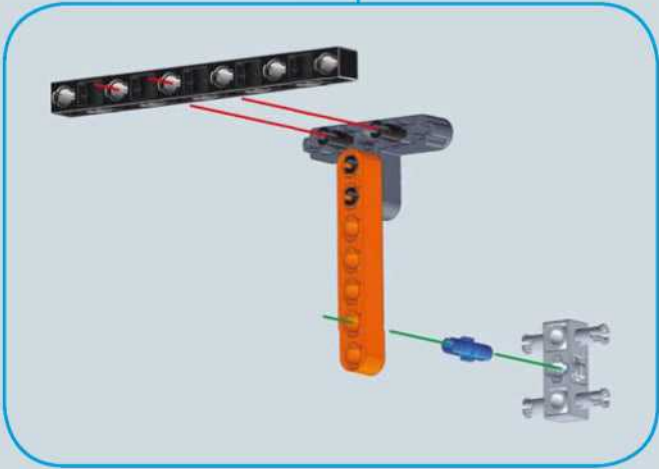
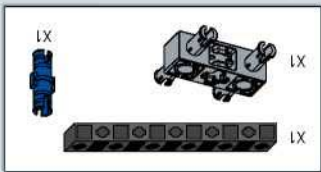
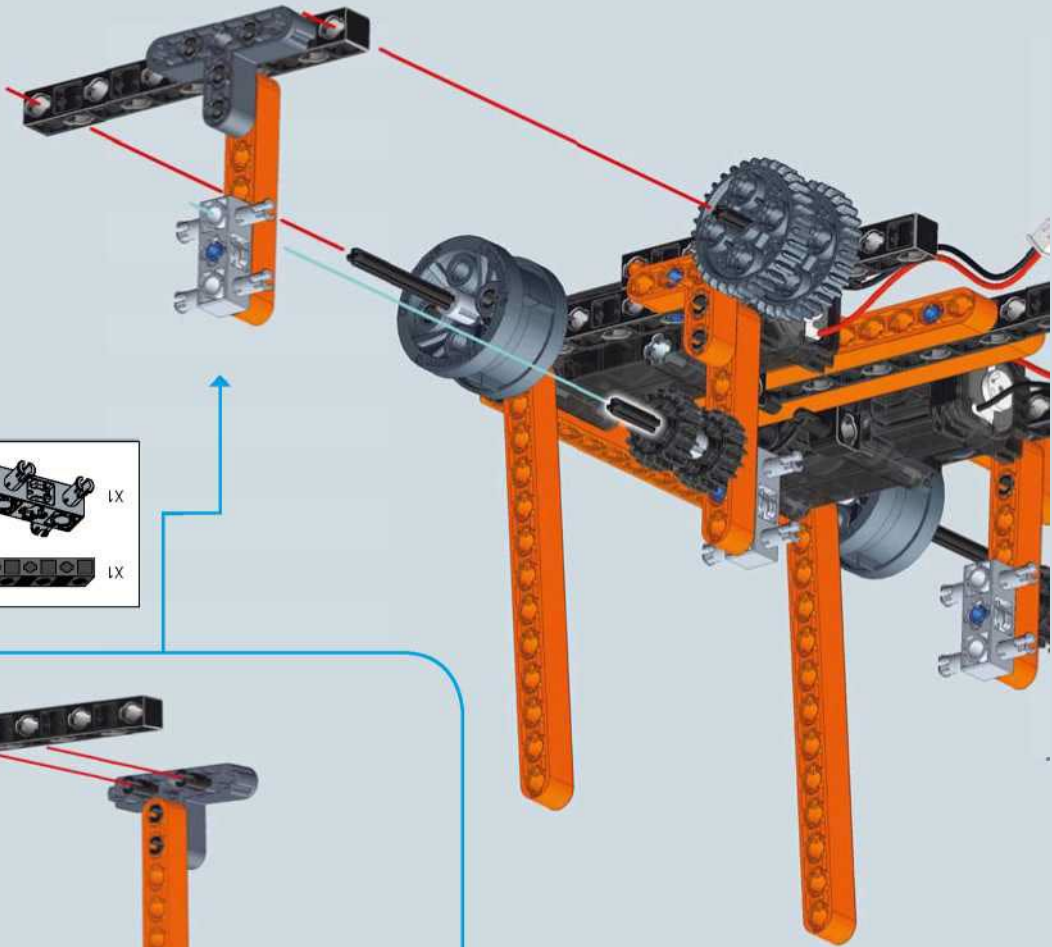

18

17

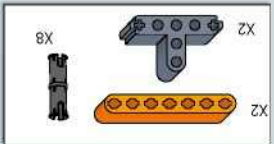
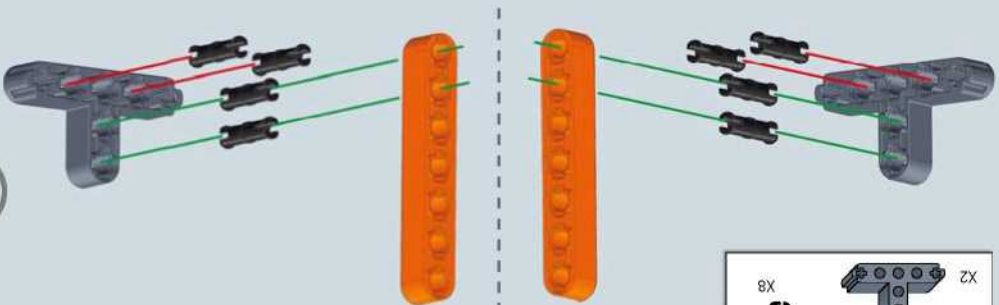

19

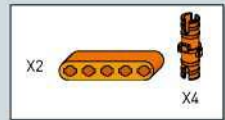
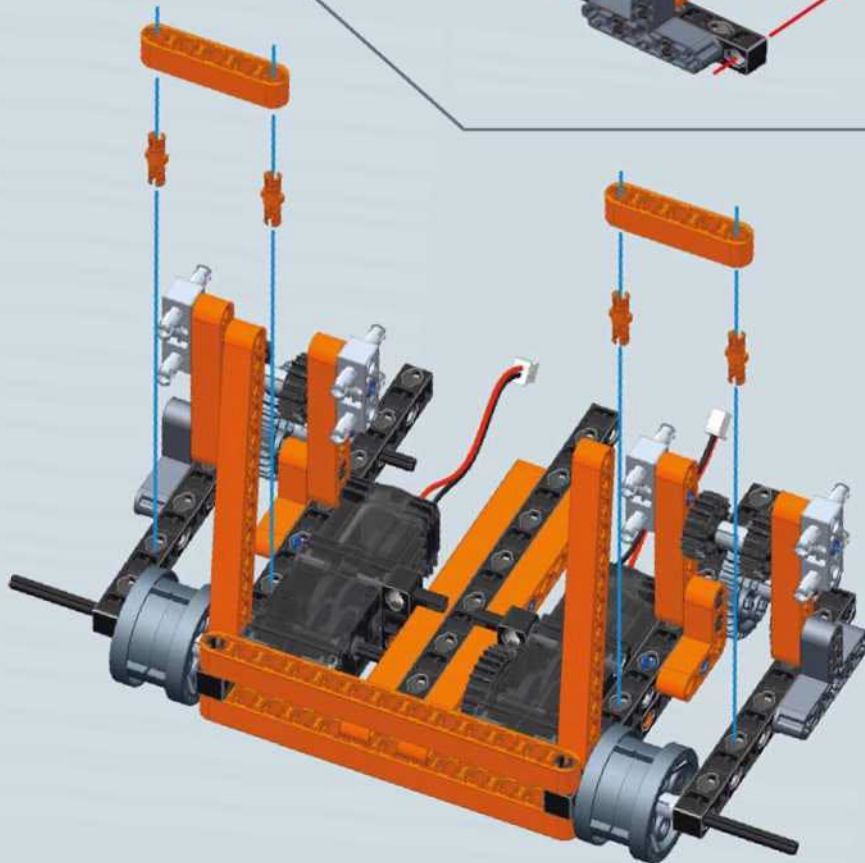
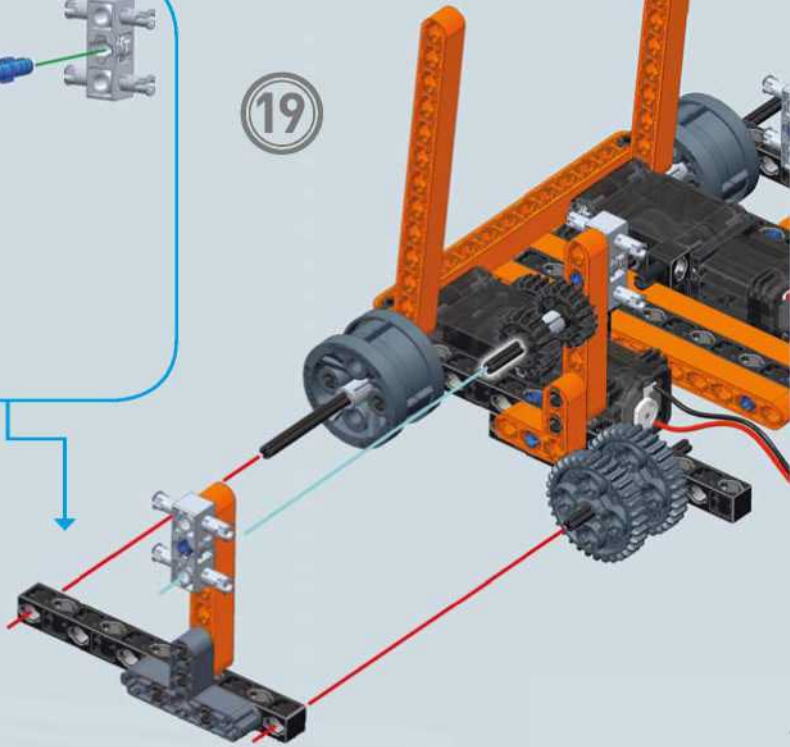
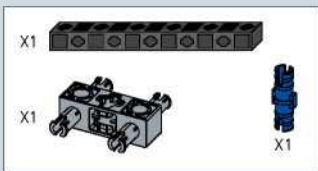
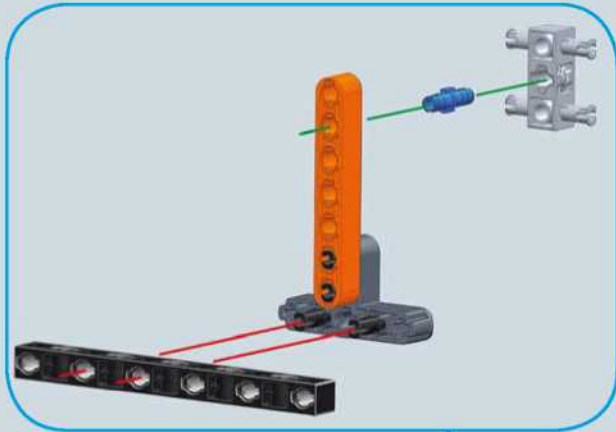

20

21

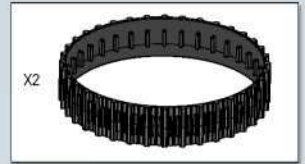
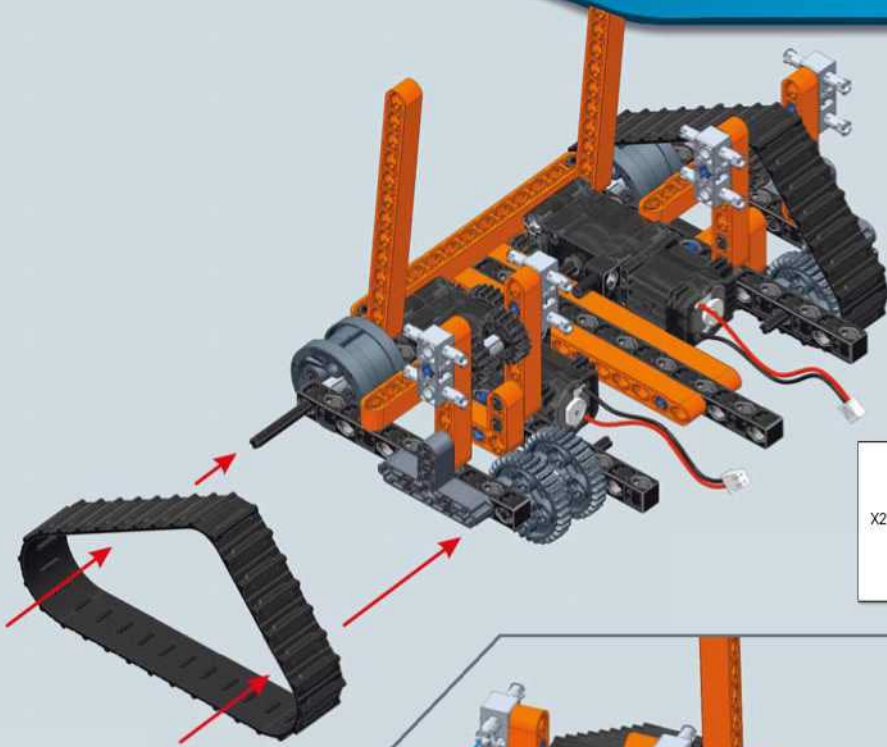

22

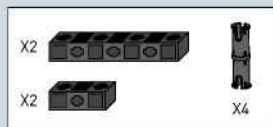
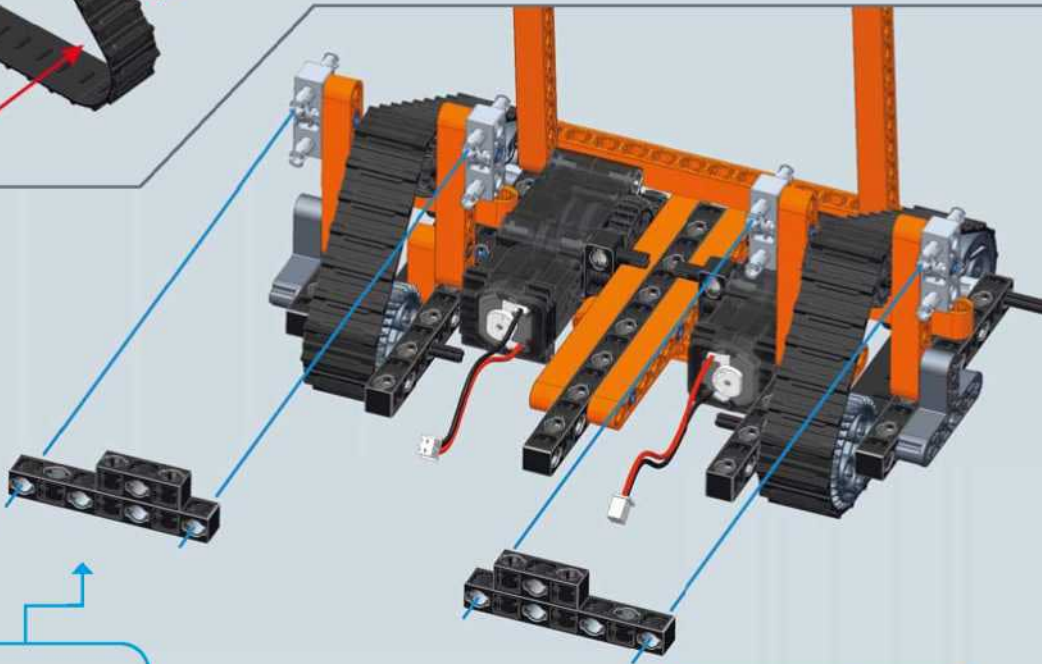



13

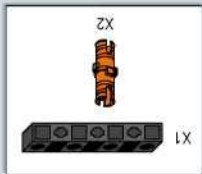
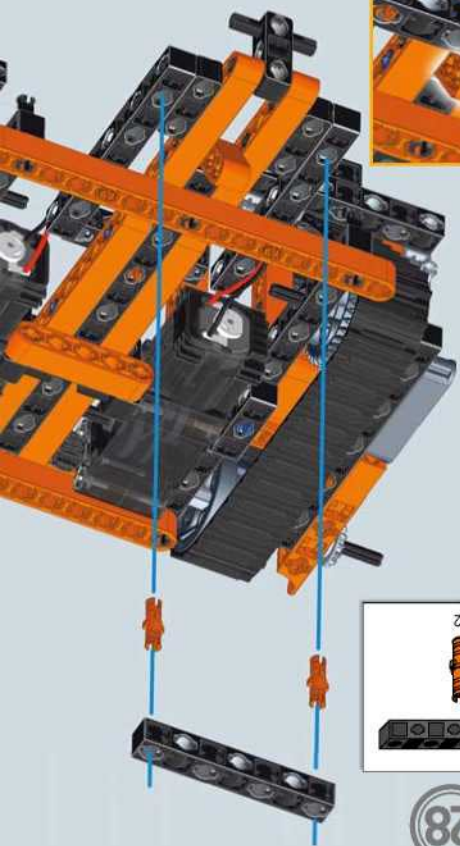
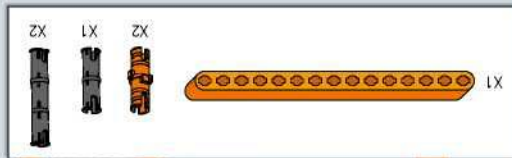

14

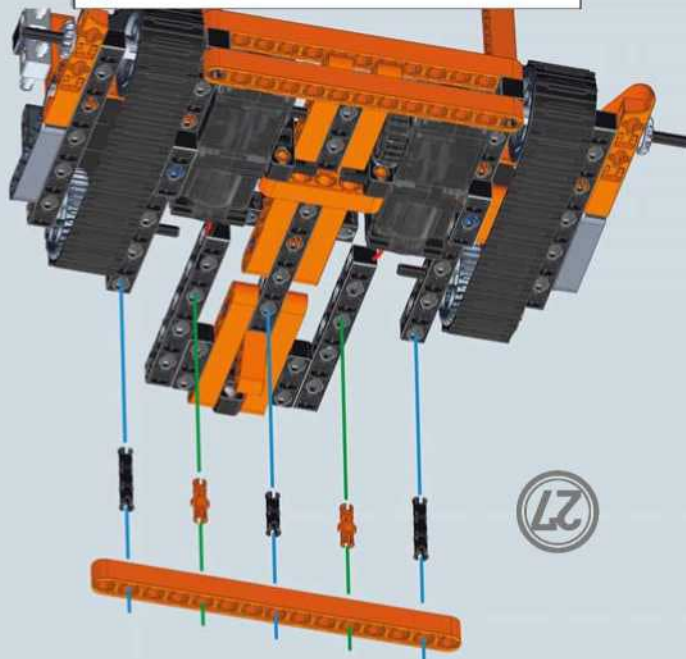

17



16

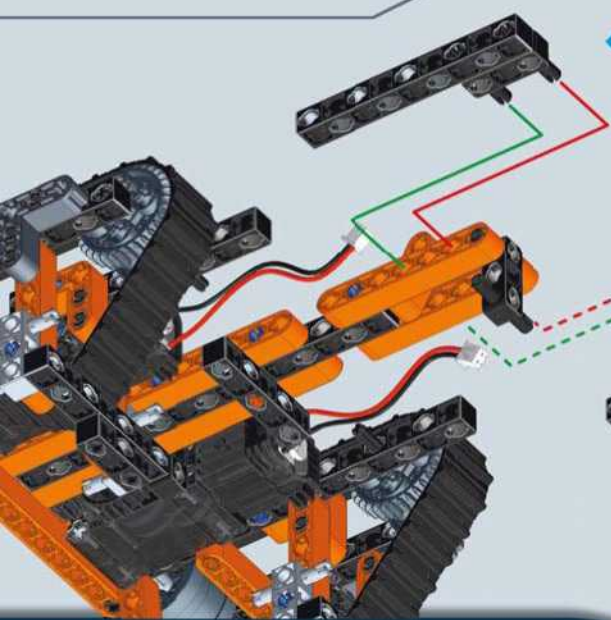
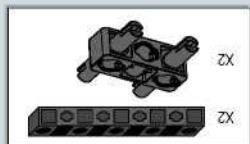



29

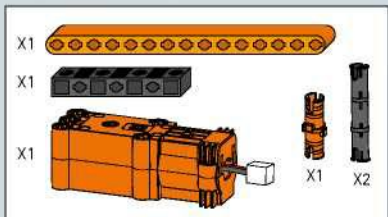

5

30

31

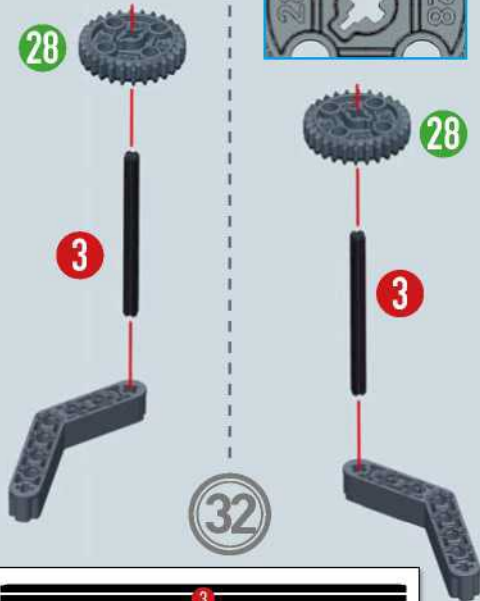
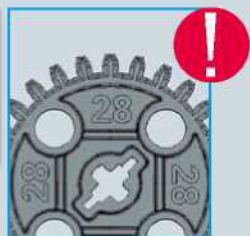
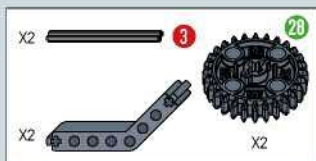
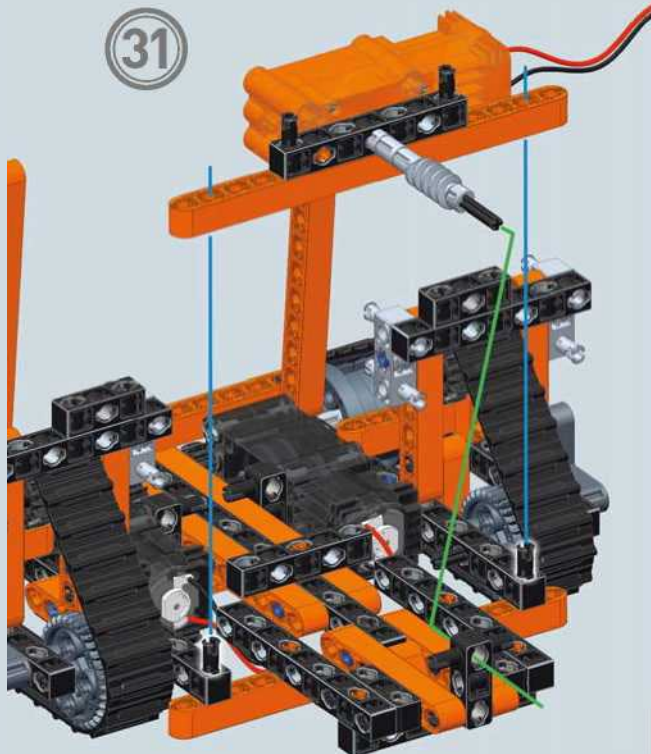

32



33

Zkontrolujte, zda jsou tyče správně umístěny

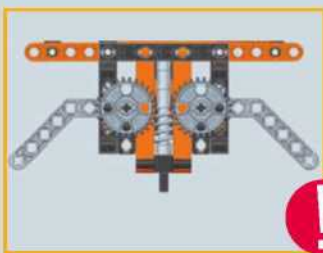

X2 

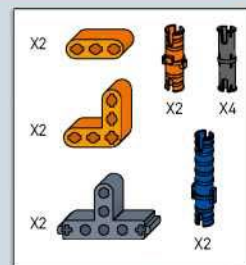
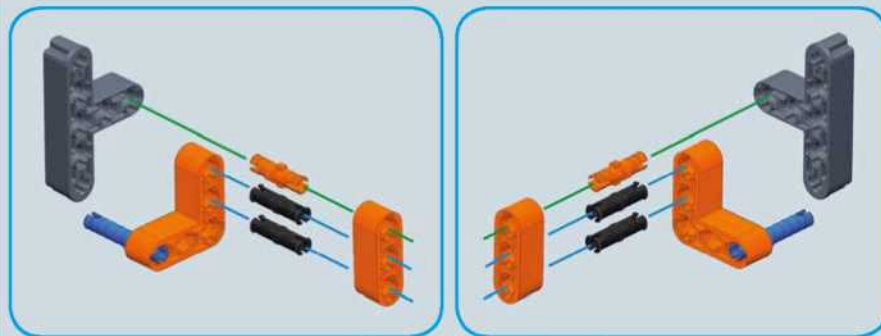

34

35



36

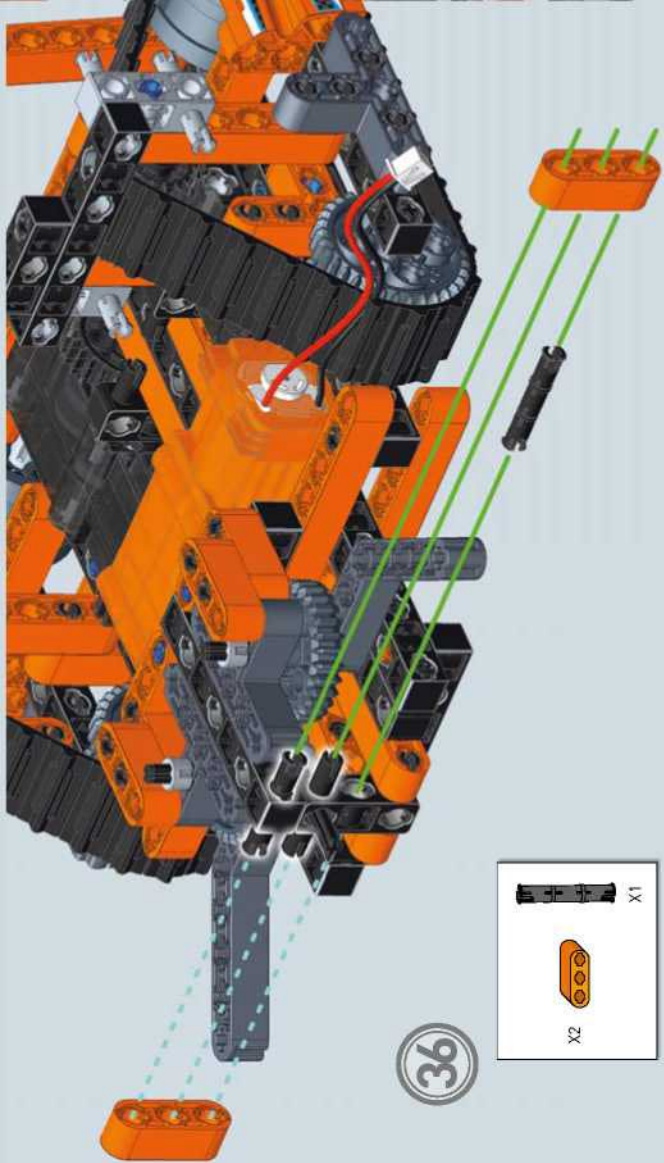
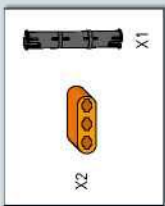



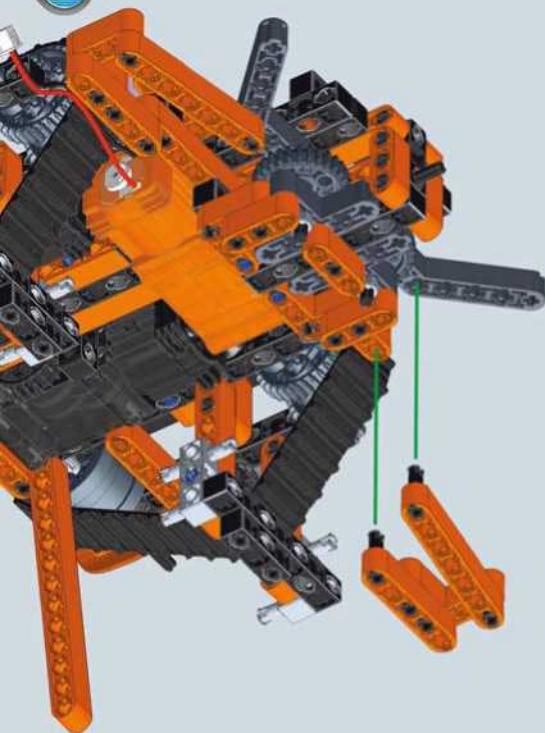

39

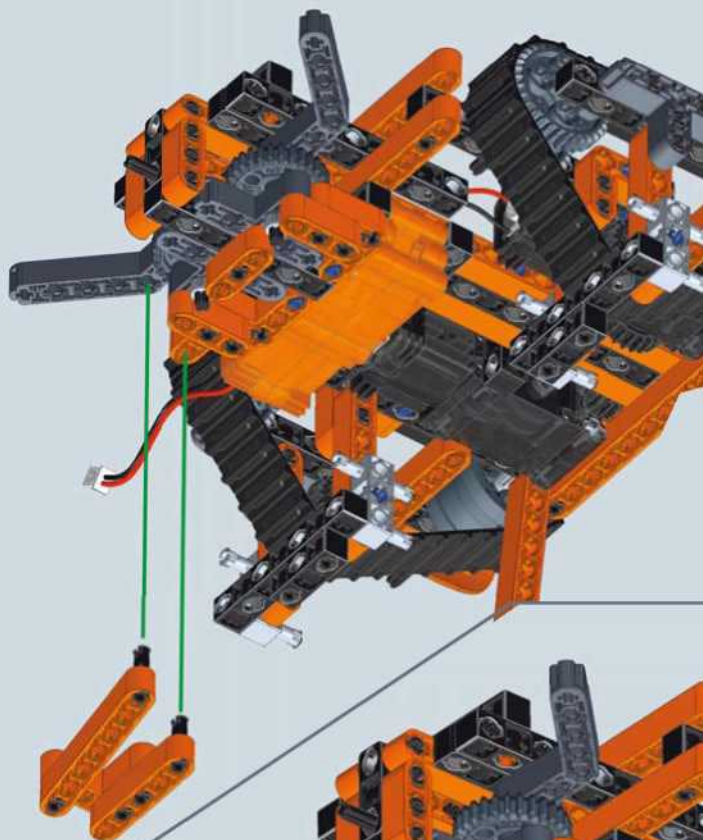

37

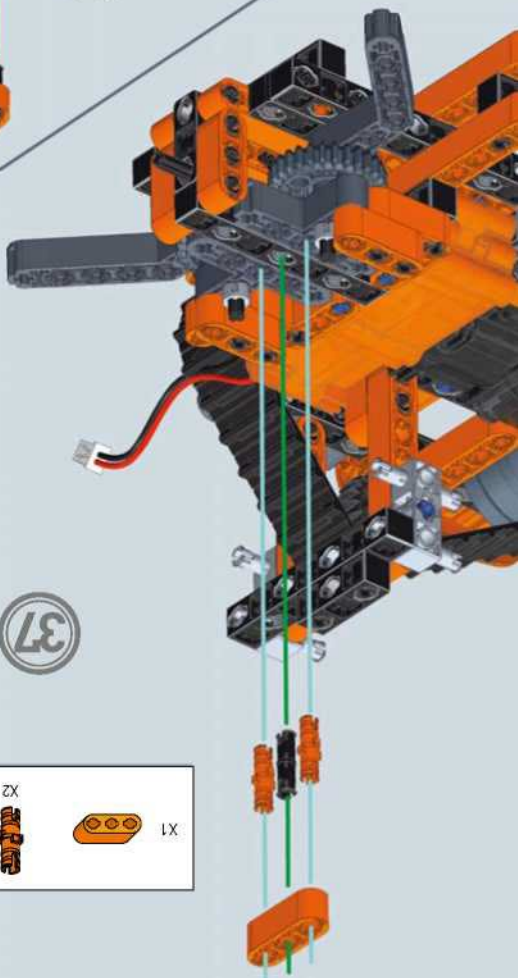

38

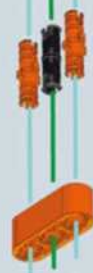
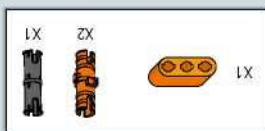
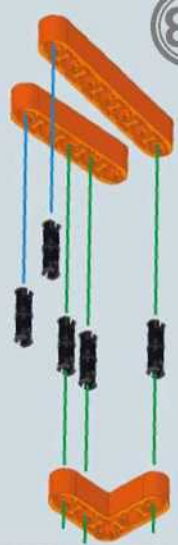
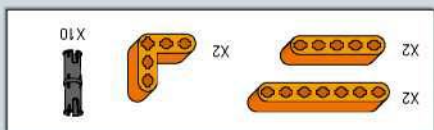

40

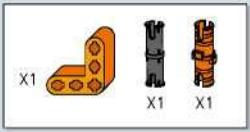
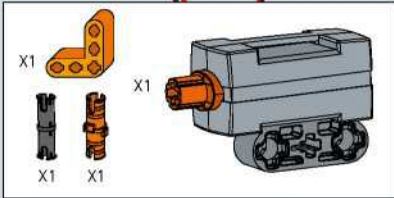
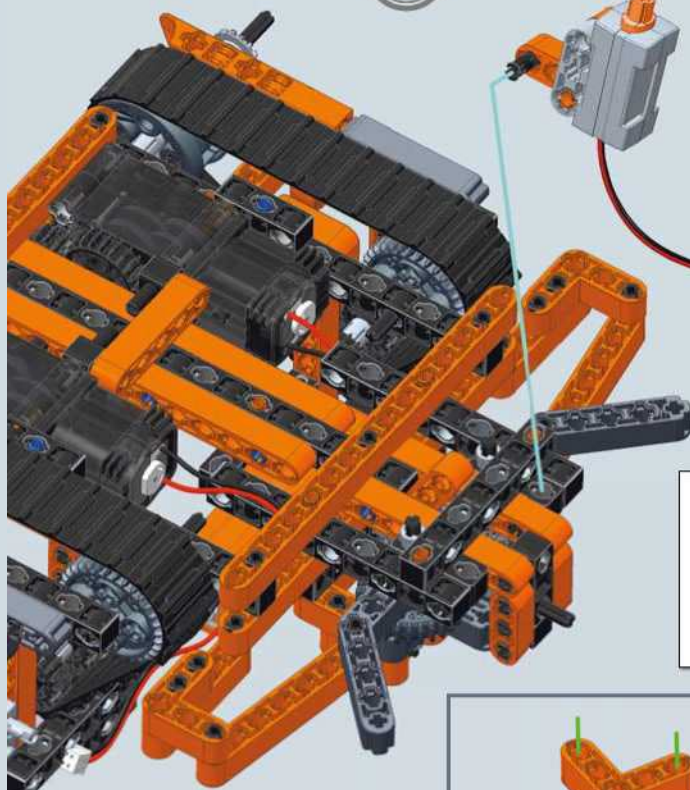
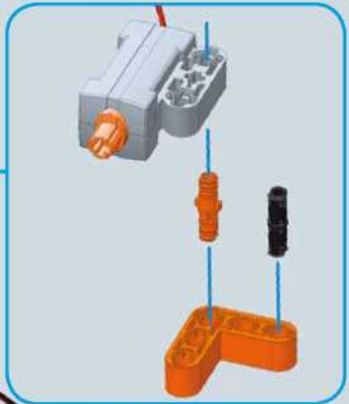

41

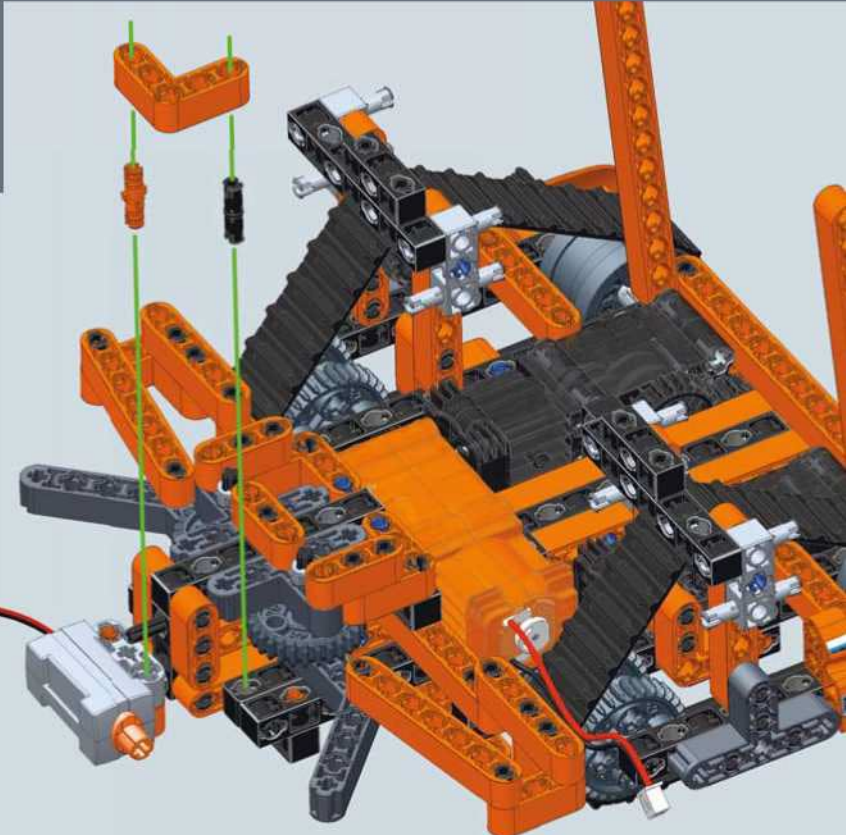

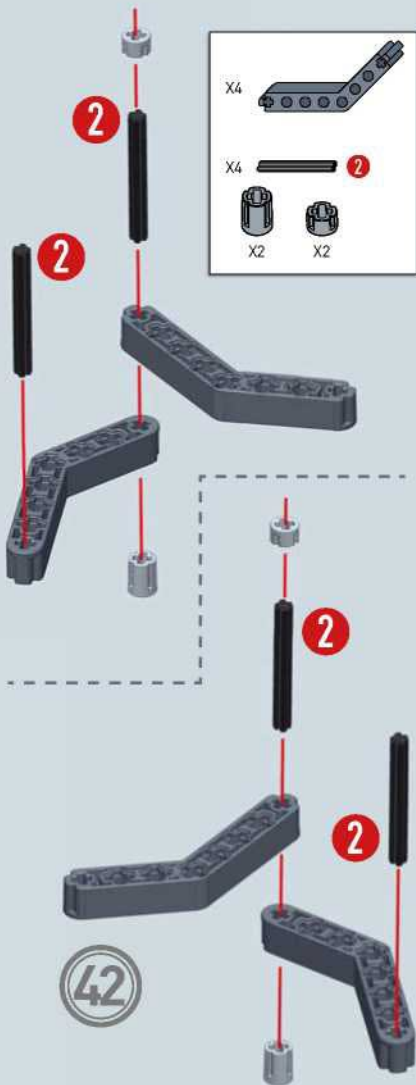

1:1    

42

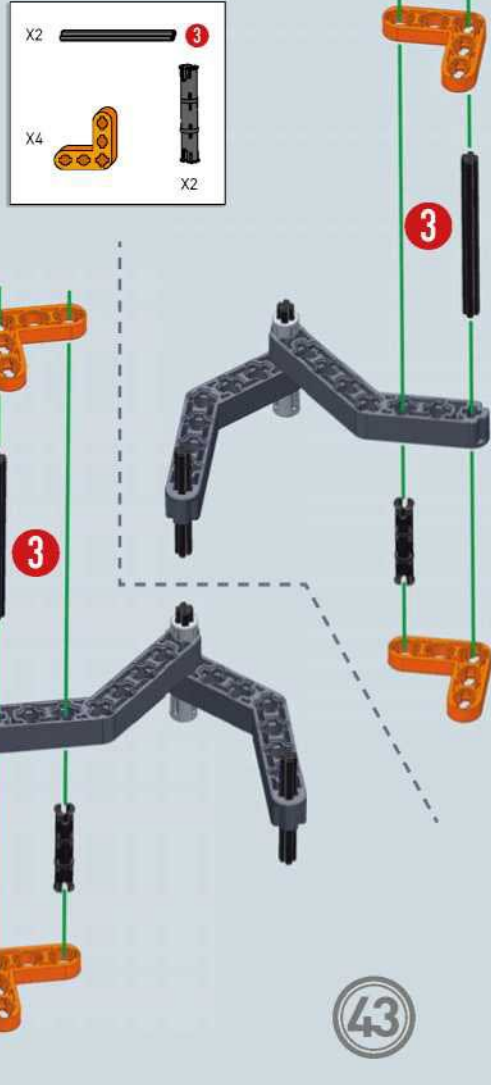

1:1    

43

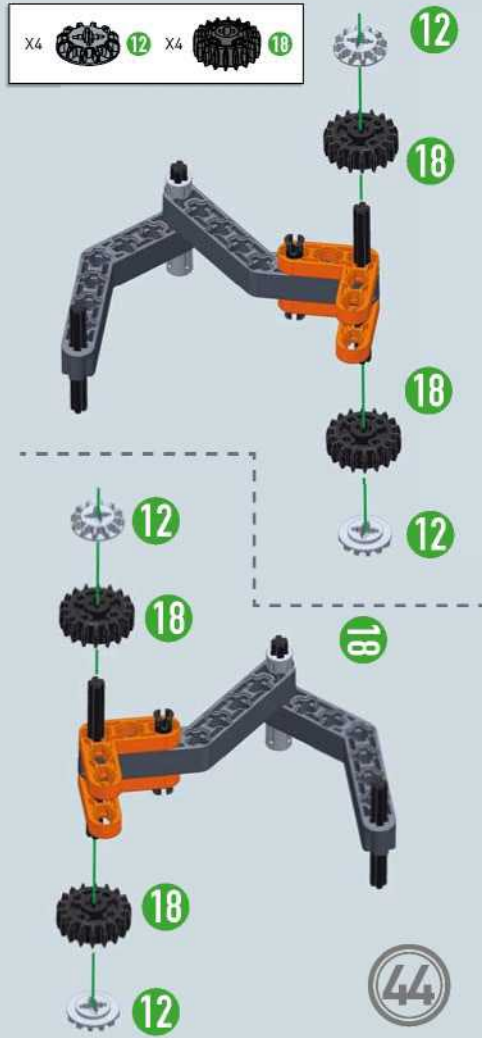

12

18

18

18

12

12

18

18

12

12

44



45

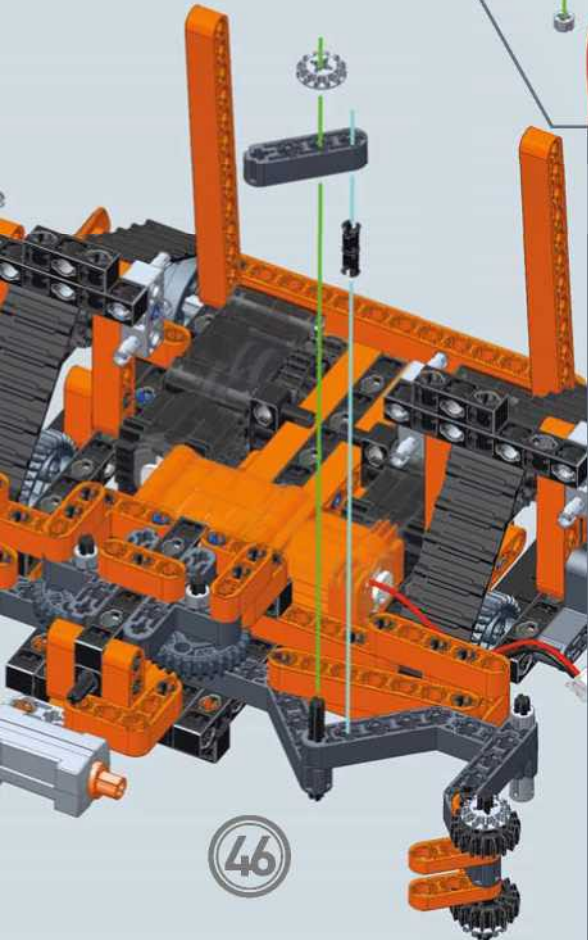
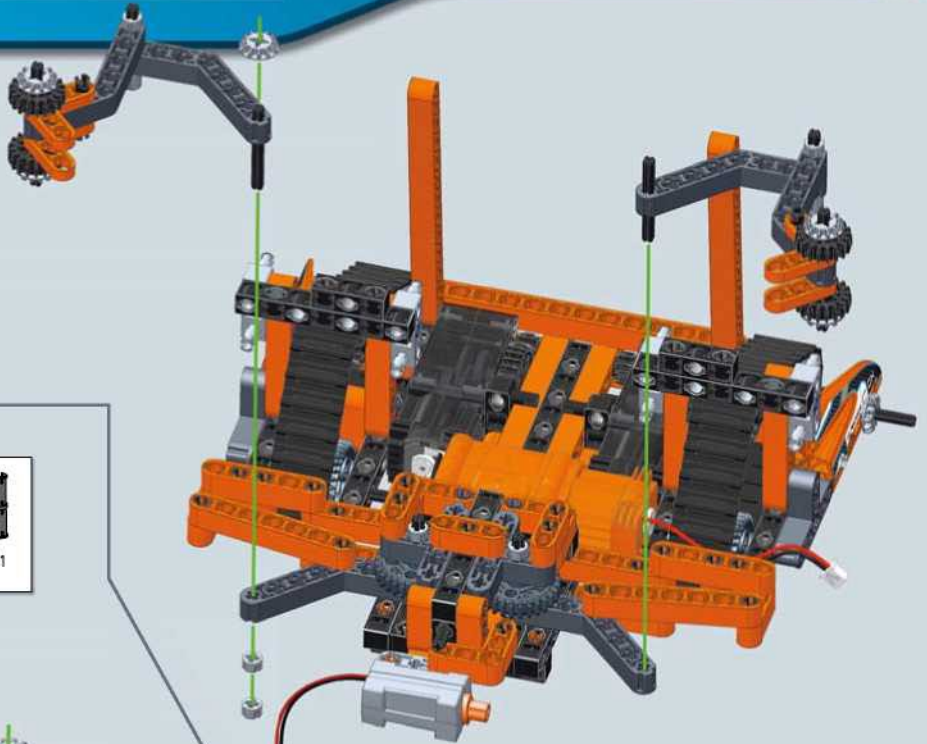
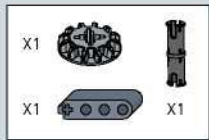

46

Otočte model vzhůru  
nohama vzhůru nohama

47

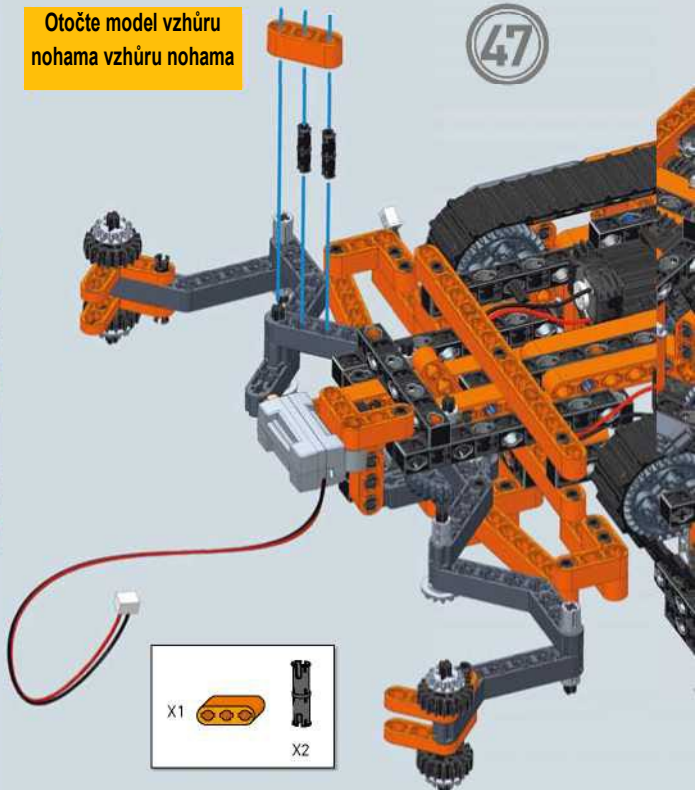

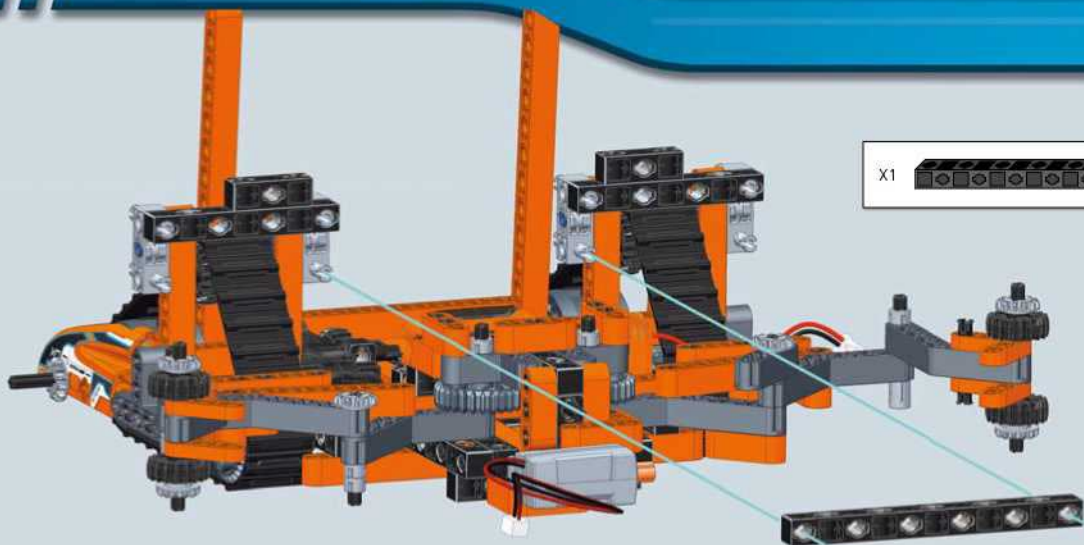

48

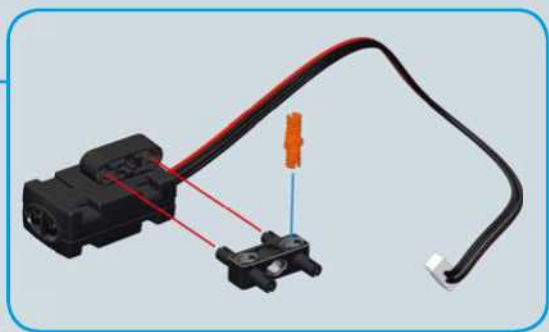
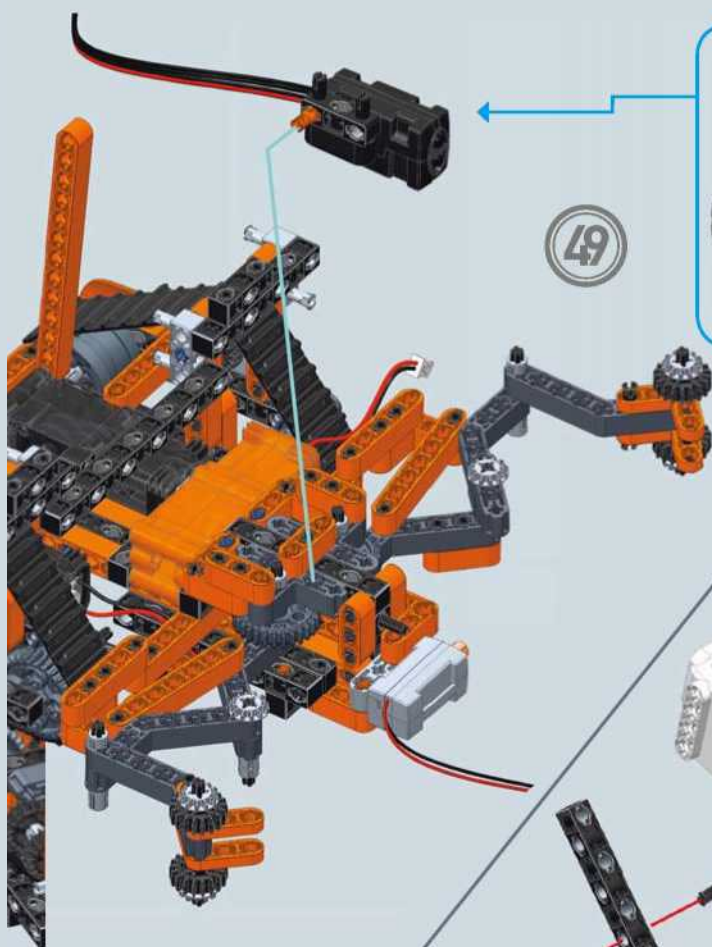

49

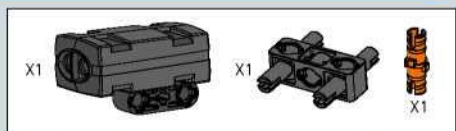

50

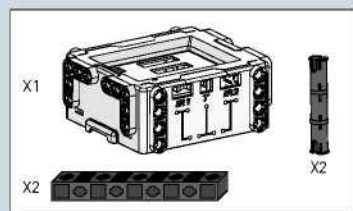
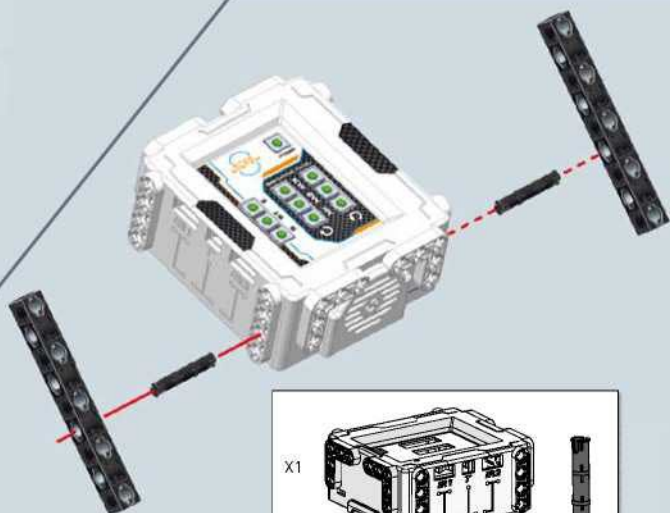

21

51

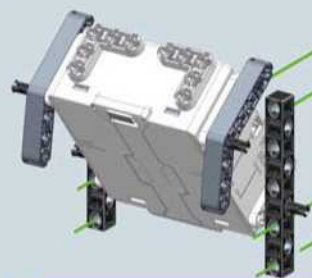
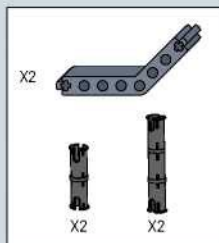
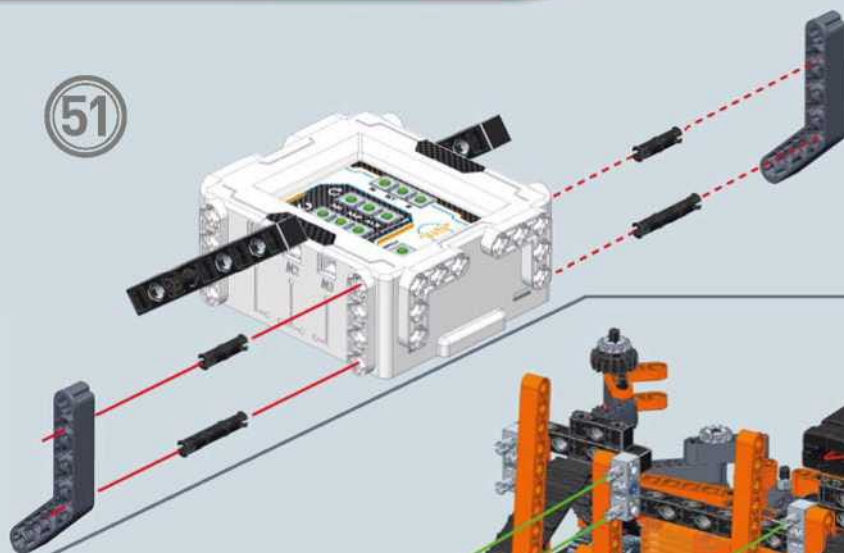

52

### PŘIPOJTE MOTORY K CENTRÁLNÍ MODUL

Umístěte model podle obrázku a připojte černý motor vlevo k portu M1 a černý motor vpravo k portu M2. Připojte oranžový motor k portu M3

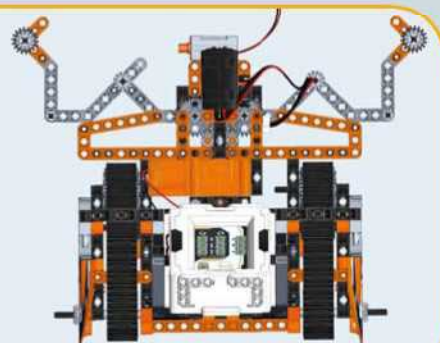
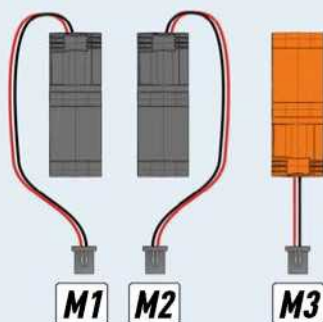

### PŘIPOJENÍ SENZORŮ NA CENTRAL

Připojte IR senzor k portu IR2. Připojte dotykový senzor k portu T.

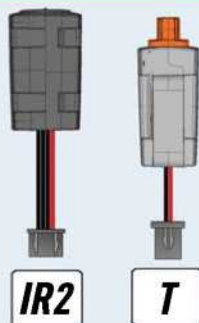

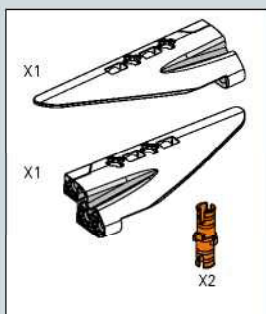

53

Připevněte modul ke dvěma oranžovým tyčím.

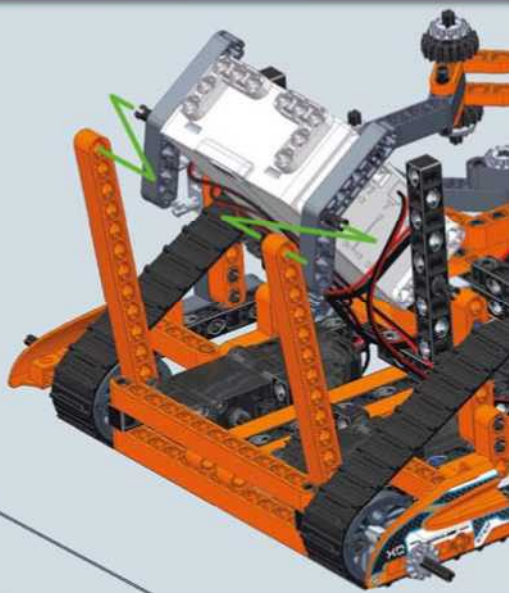

54

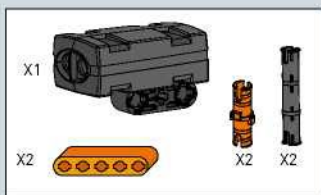
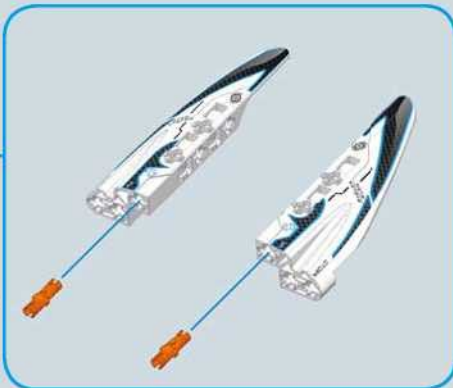

55

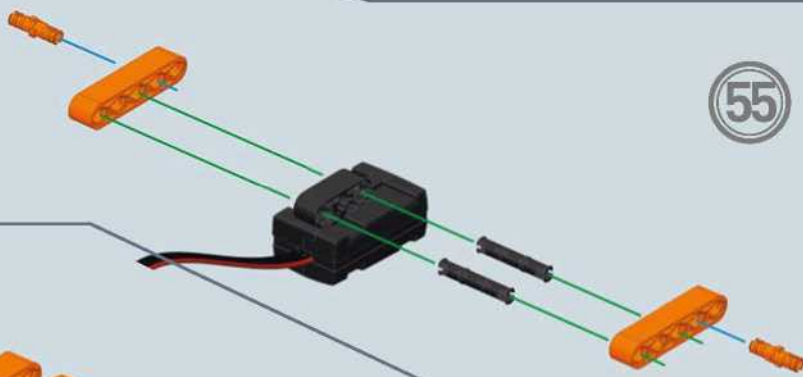

56

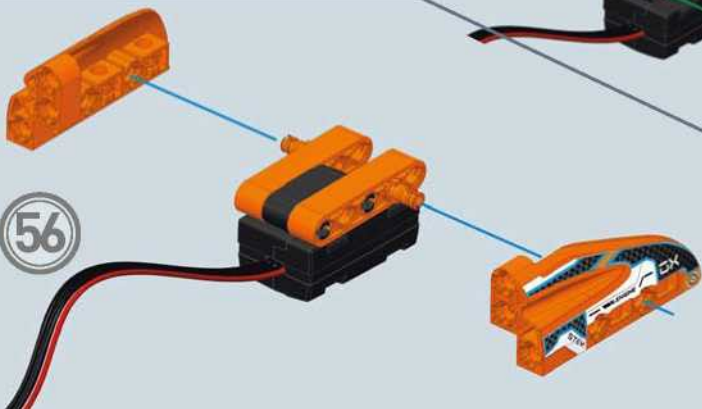
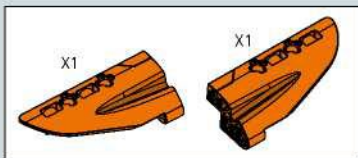

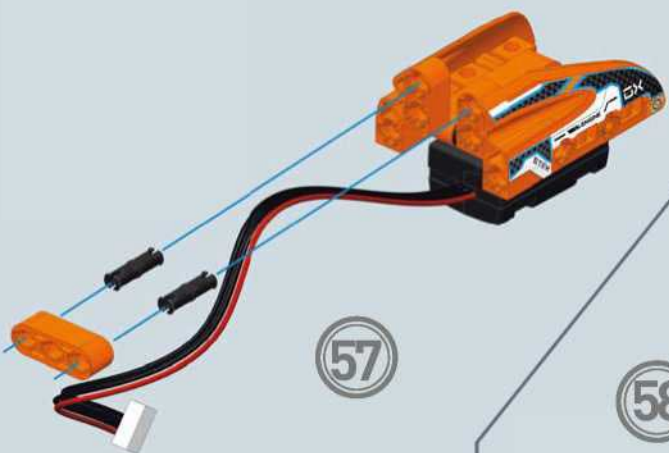

57

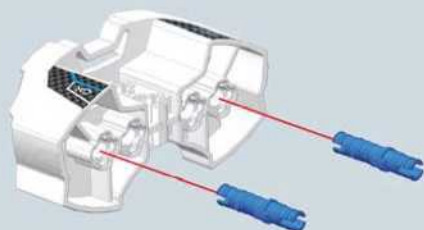
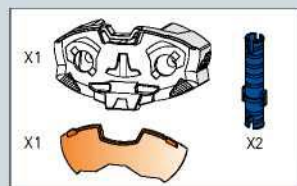

58

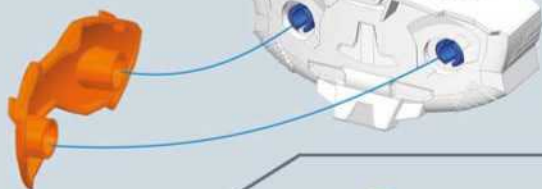

59

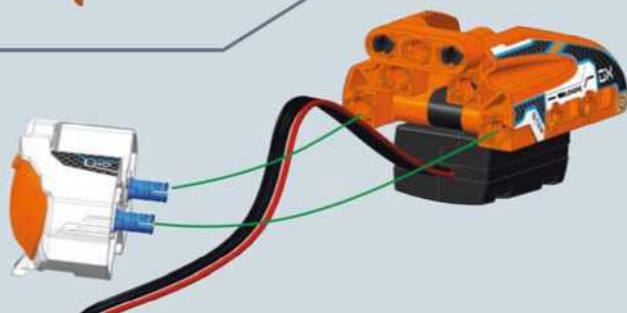

60

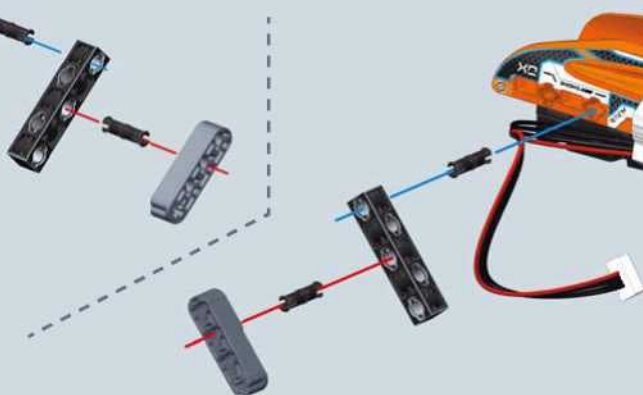
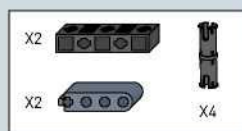



61

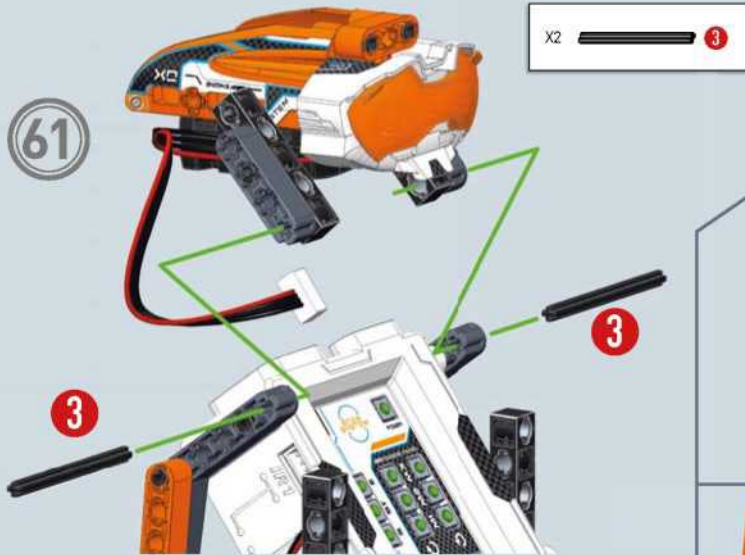

1:1 

### PŘIPOJENÍ SENZORU K CENTRÁLNÍ JEDNOTCE

Připojte IR senzor k portu IR1.



IR1



X1



X1

X2



62

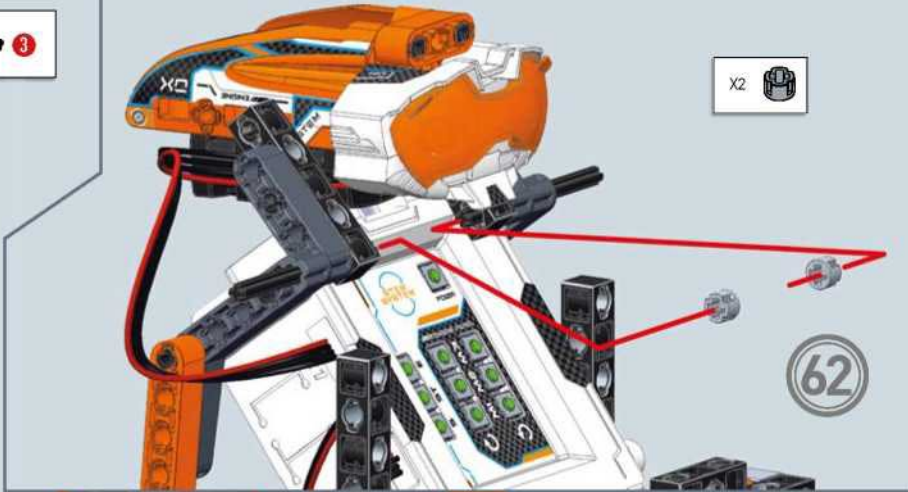

63

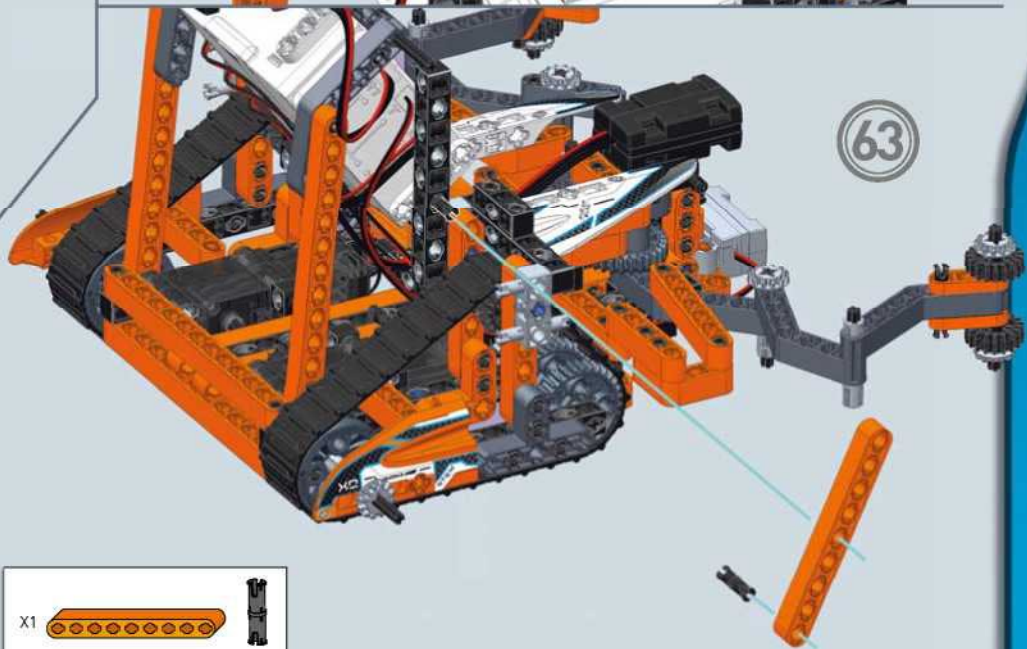

65

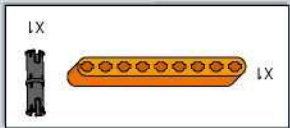
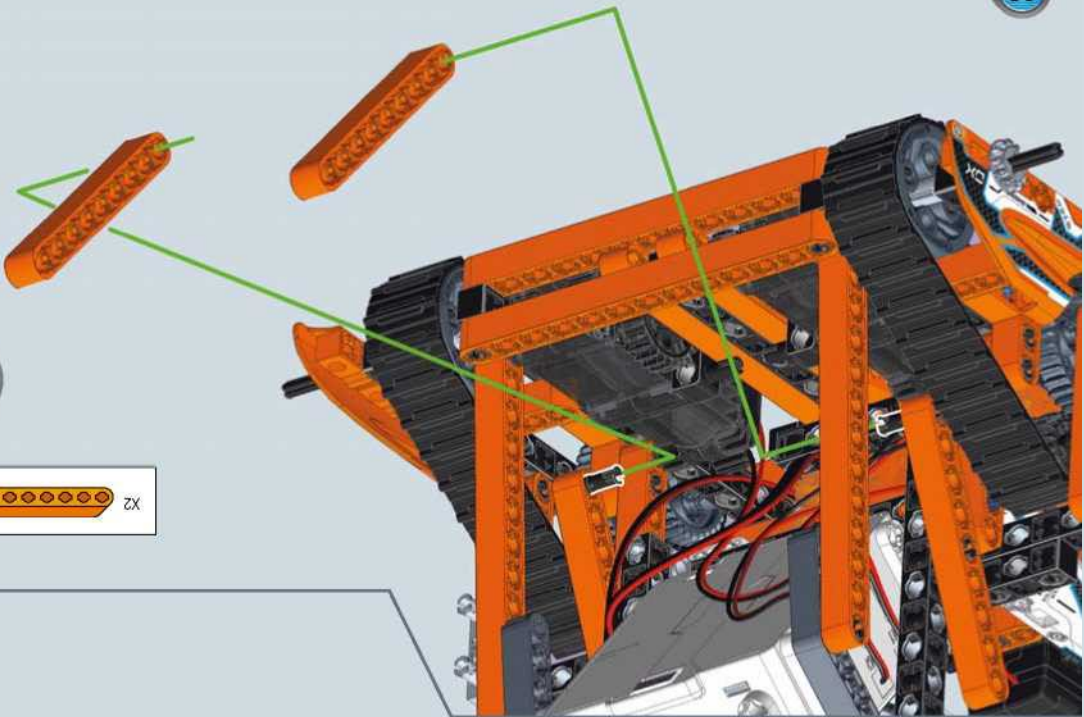

79

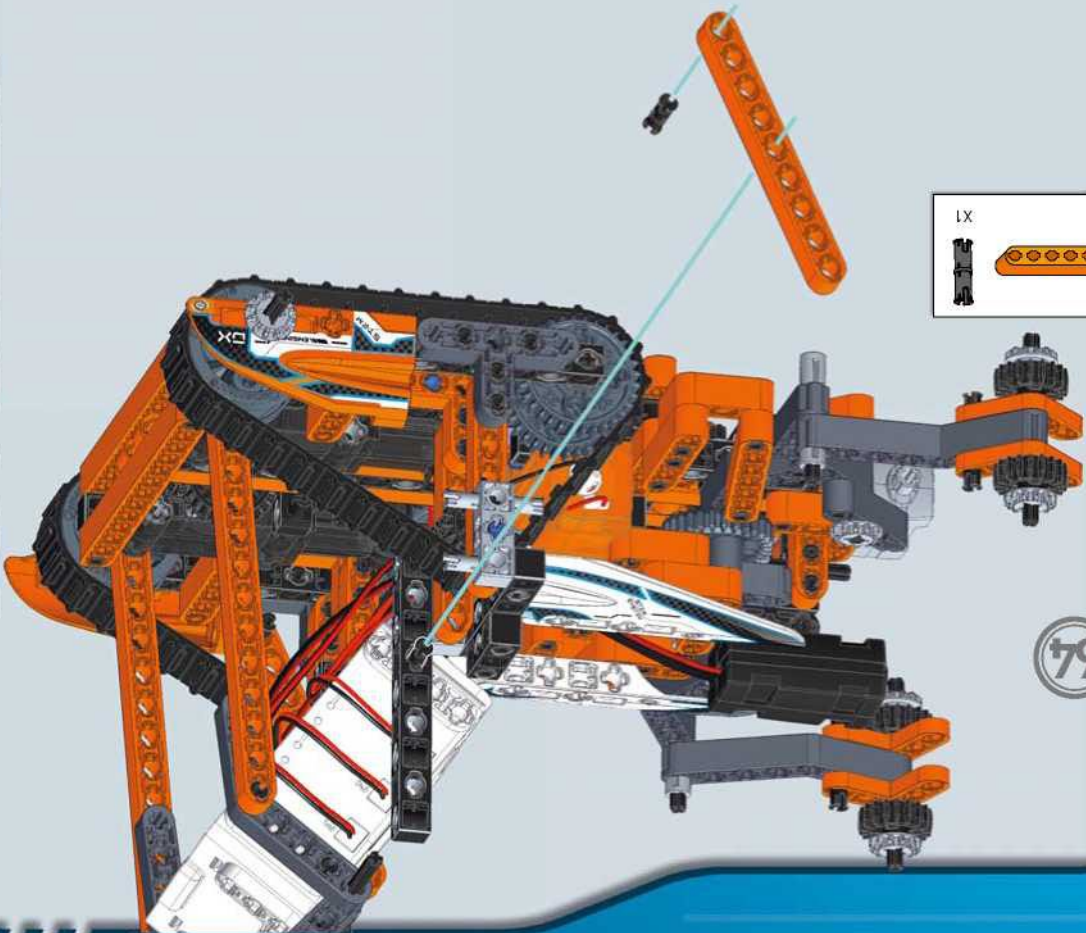

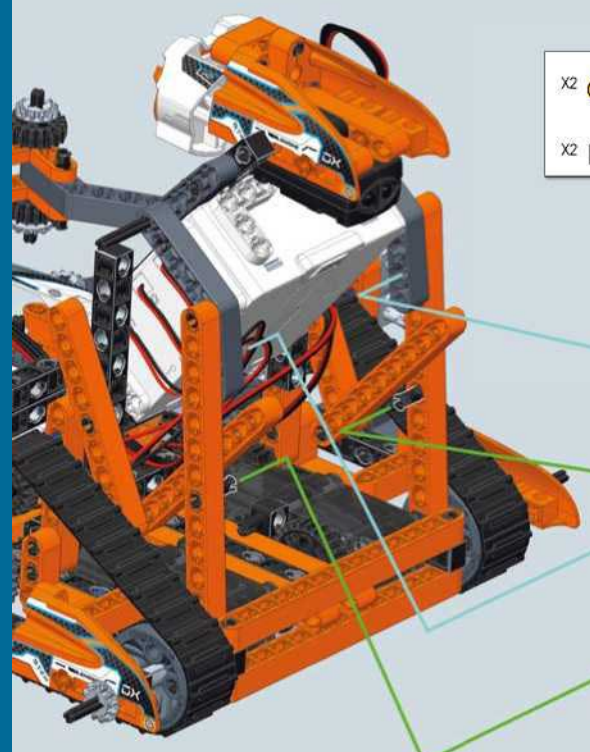

- X2
- X2
- X6

66

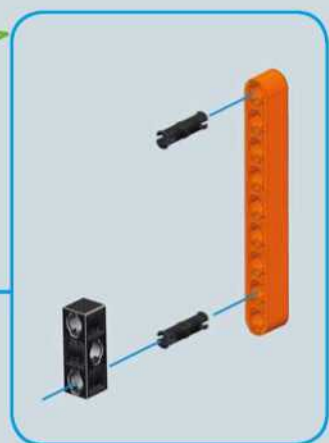
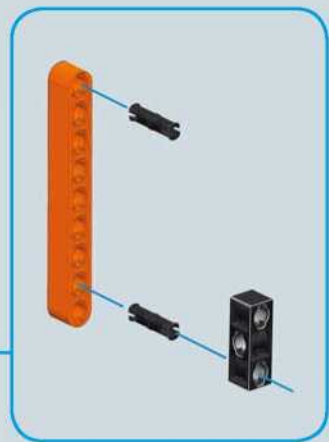

67

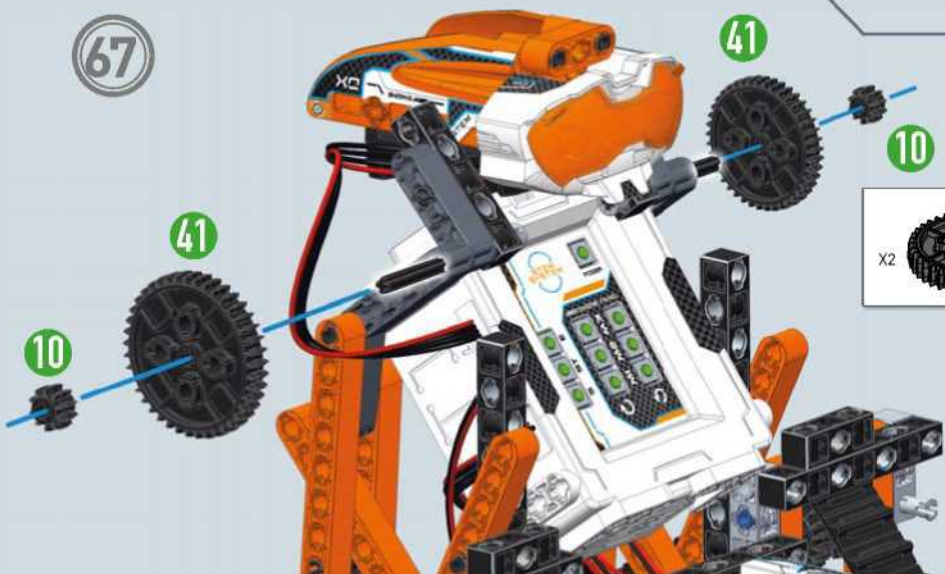

- X2
- X2

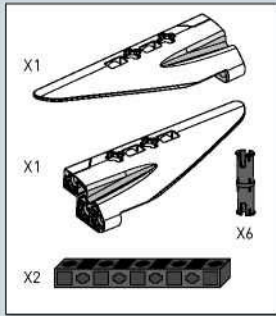

68

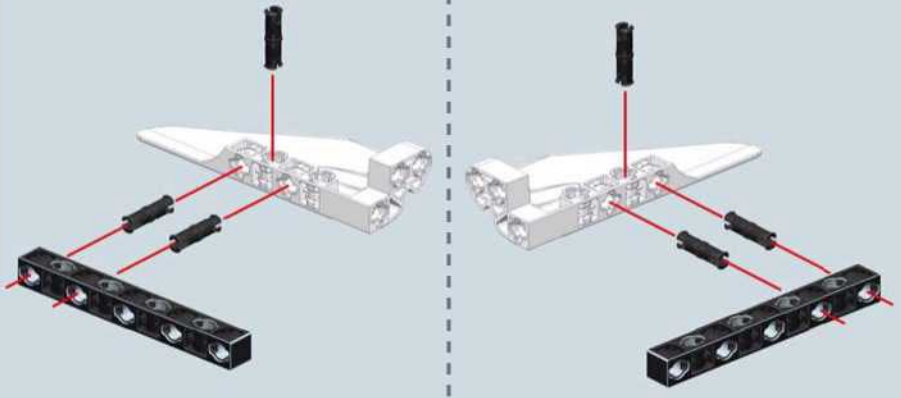

69

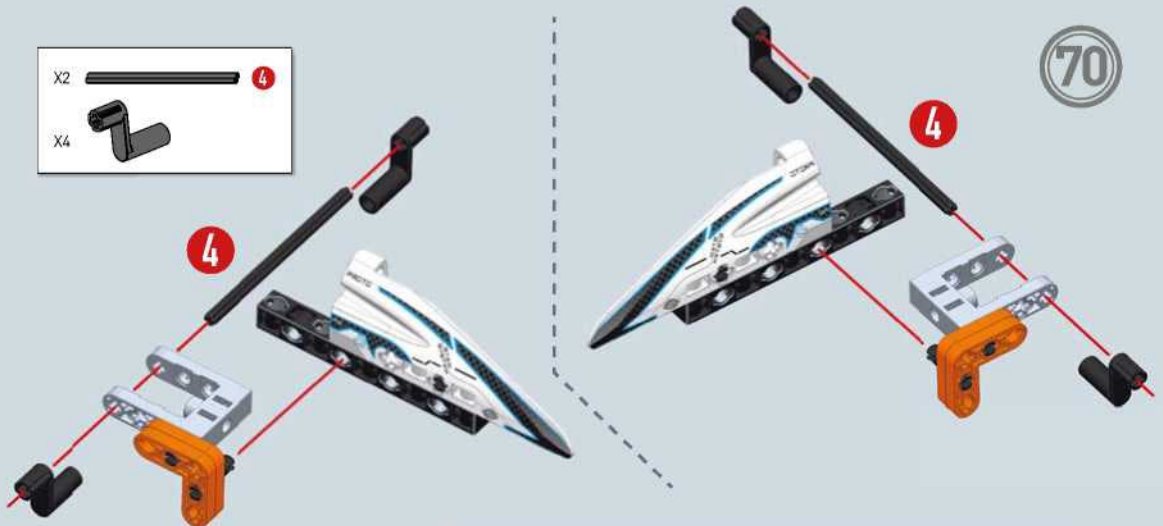
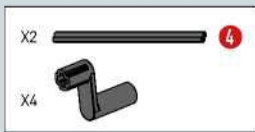
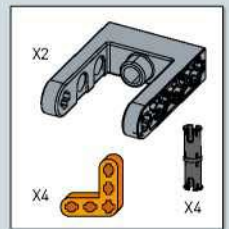
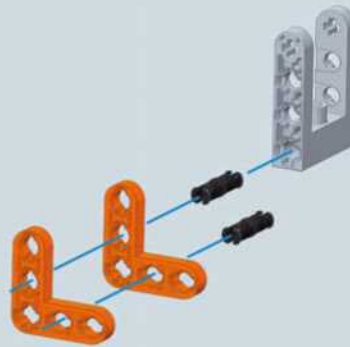
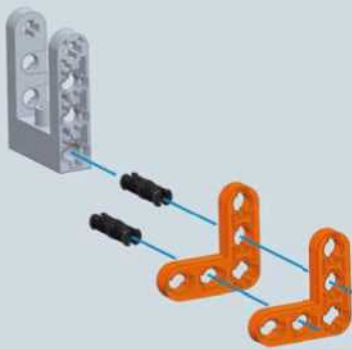

70



71



72



DOKONČENÝ MODEL

