

coding
lab

RoboMaker[®]

výuková laboratoř robotiky

pro

X4 • GUARDIAN

LEGO® MINDSPRINGER™ 11330

Vědecké poradenství
v oblasti kódování a
blokové
programování: Prof.
Alessandro Bogliolo

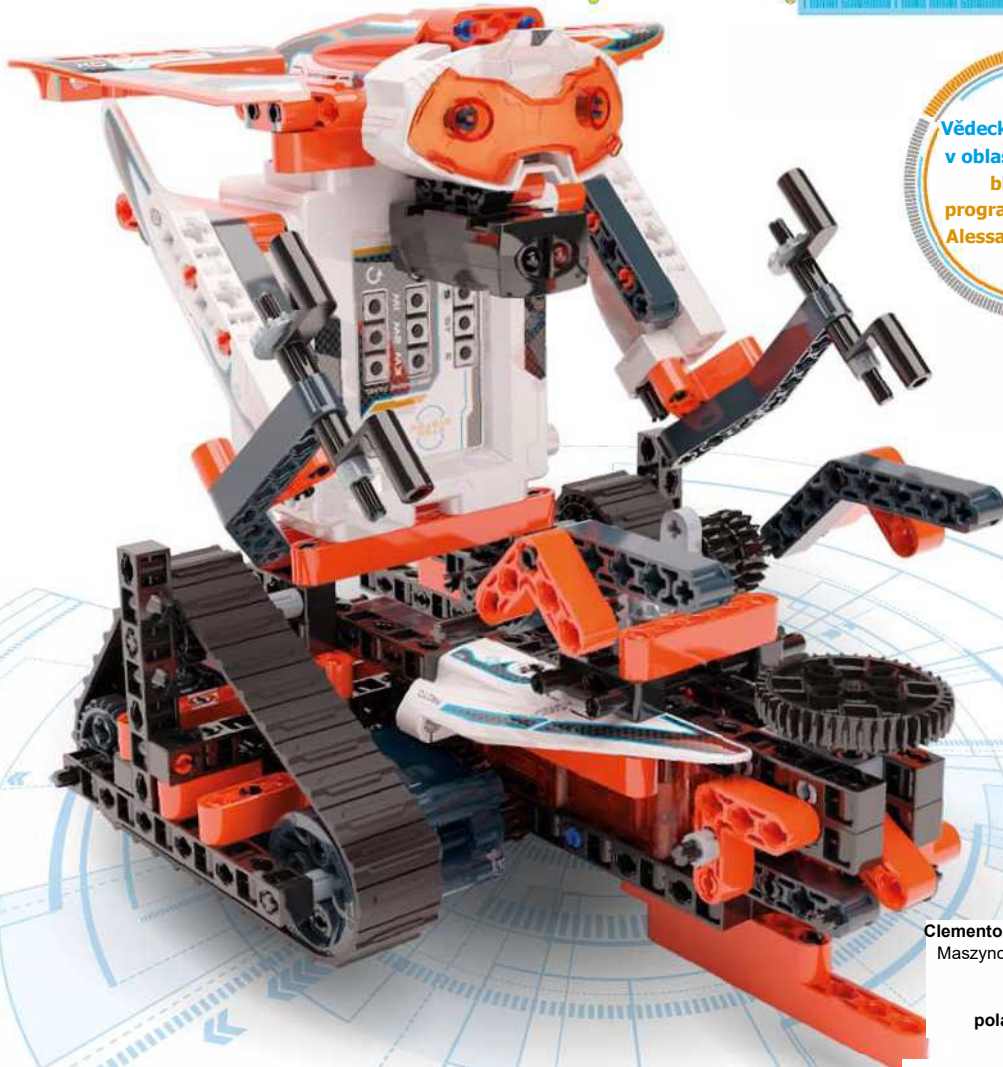

Clementoni Polska Sp. z o.o.
Maszynowa 32, 80-298
Gdansk, Polska
Tel.: +48 58 3432882
poland@clementoni.com

PRODUCENT:
Clementoni S.p.A. Zona Industriale
Fontenoce s.n.c.
62019 Recanati (MC) - Italy Tel.:
+39 071 75811
www.clementoni.com

advanced

Přečtěte si pokyny a uschovejte si je pro případnou potřebu

Clementoni

Strážci a zloději

Montáž

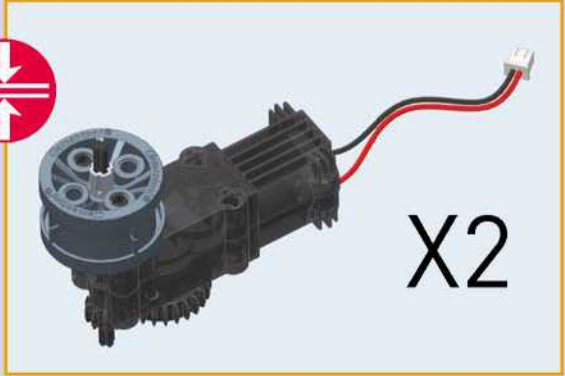
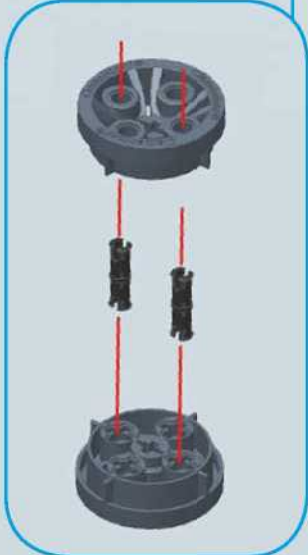
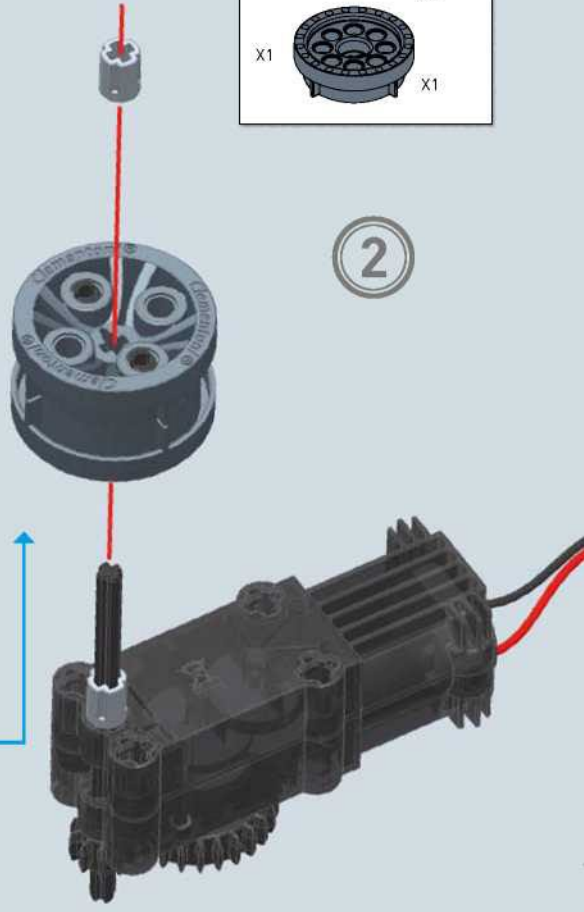
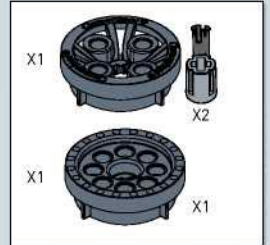
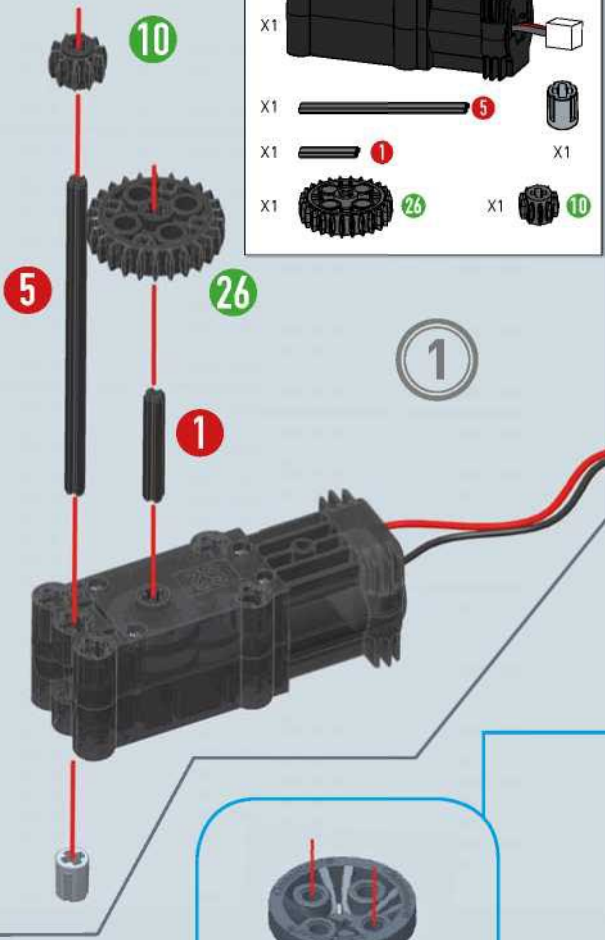
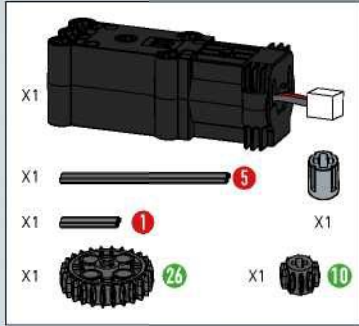

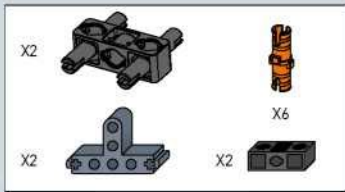

3

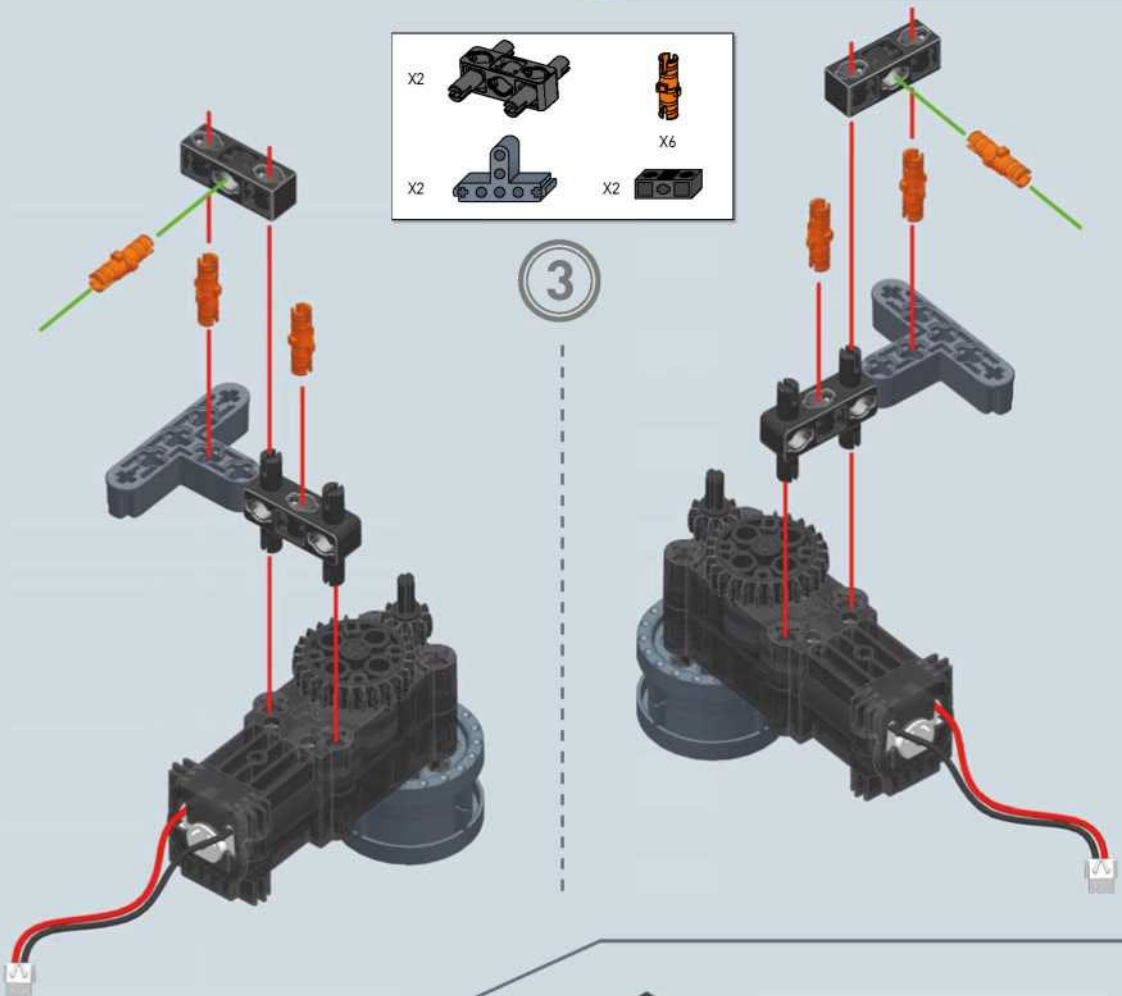

4

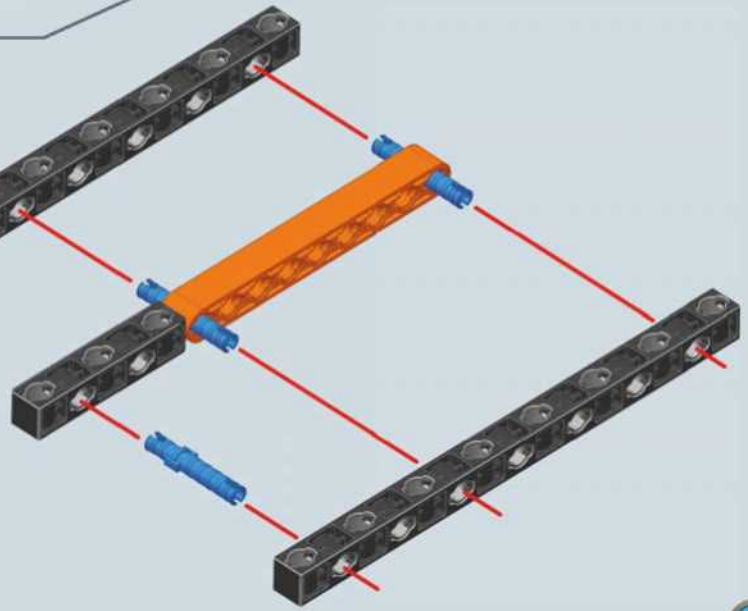
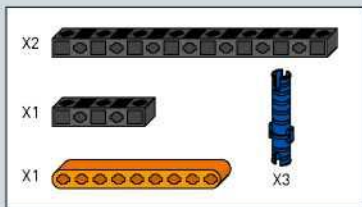

3

8

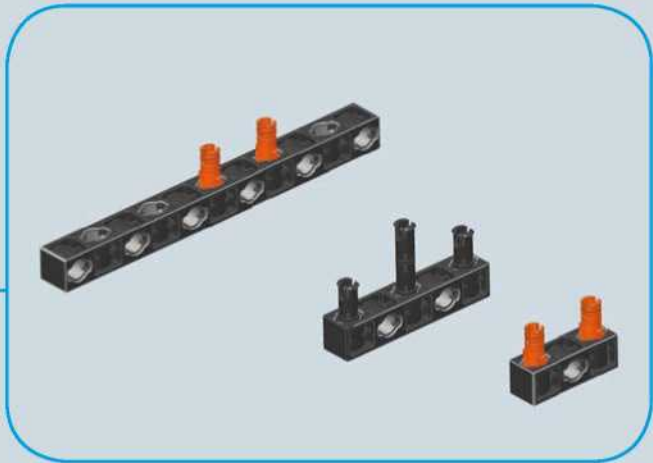
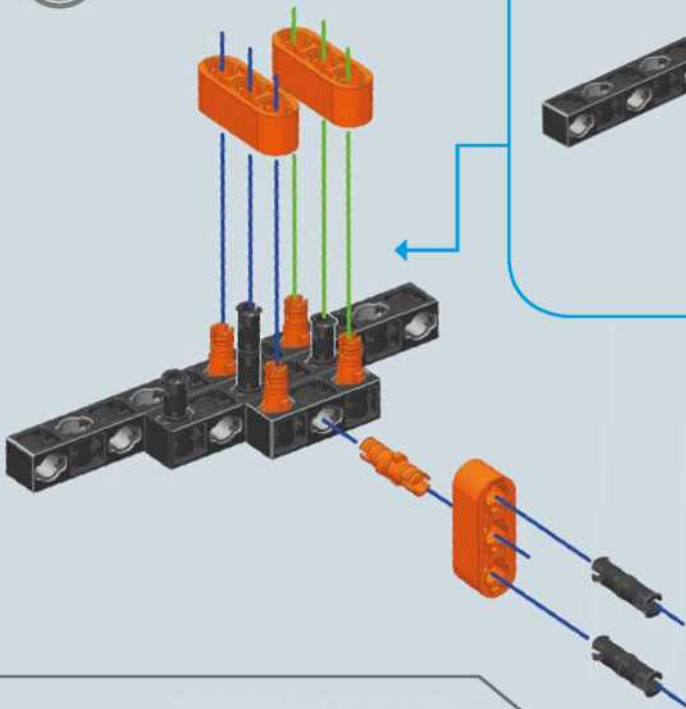

- X1
- X1
- X1
- X3
- X5
- X4
- X1

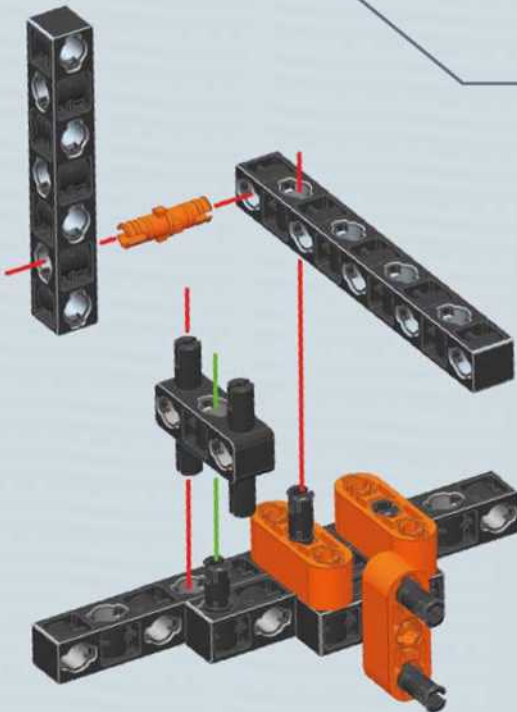

9

- X1
- X1
- X1
- X1

10

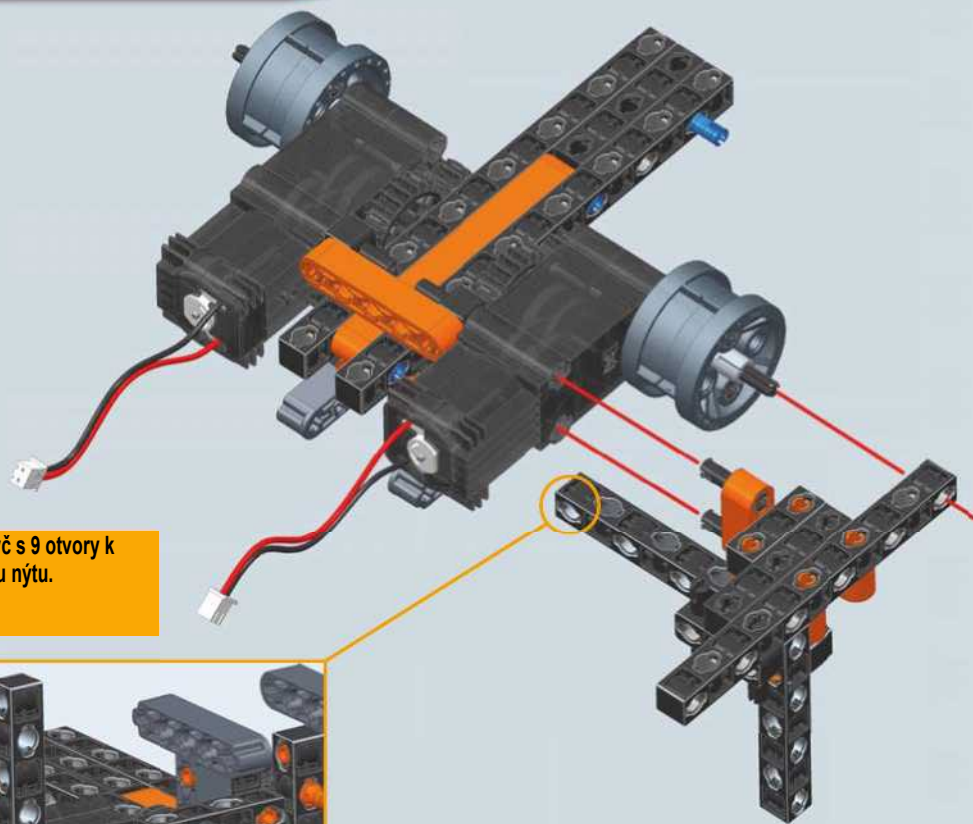



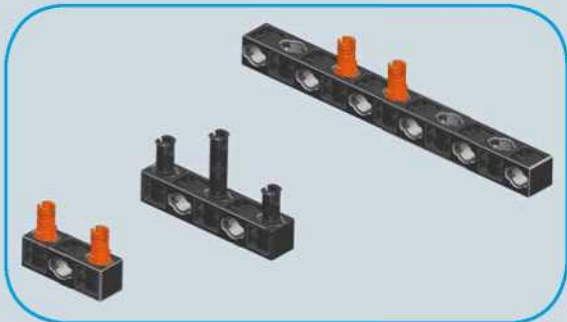
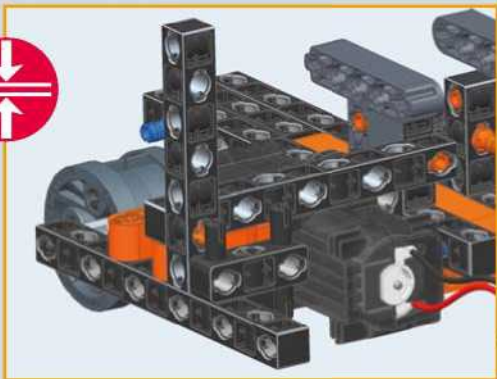

Připojte dvojitou tyč s 9 otvory k oranžovému nýtu.

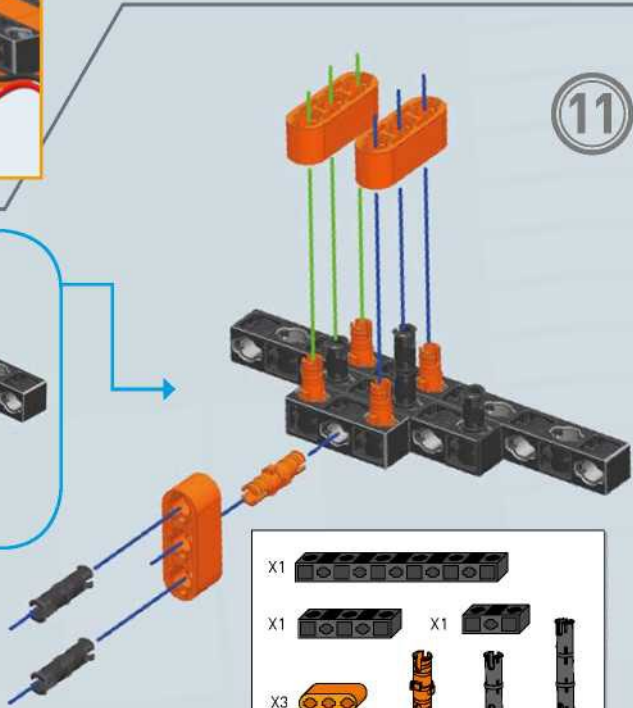

11



- | | | | | | |
|----|--|----|--|----|--|
| X1 | | X1 | | X1 | |
| X1 | | X1 | | X1 | |
| X3 | | X5 | | X4 | |
| | | X1 | | | |

- X1 
- X1 
- X1  X1 

12

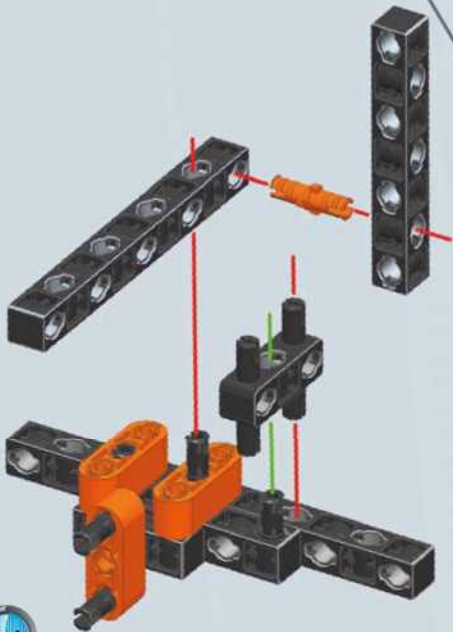

13

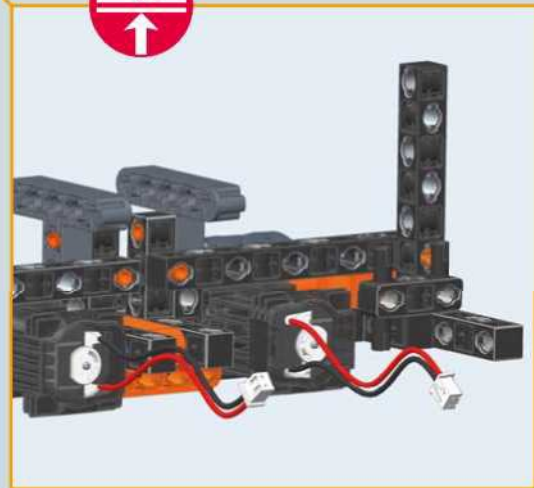
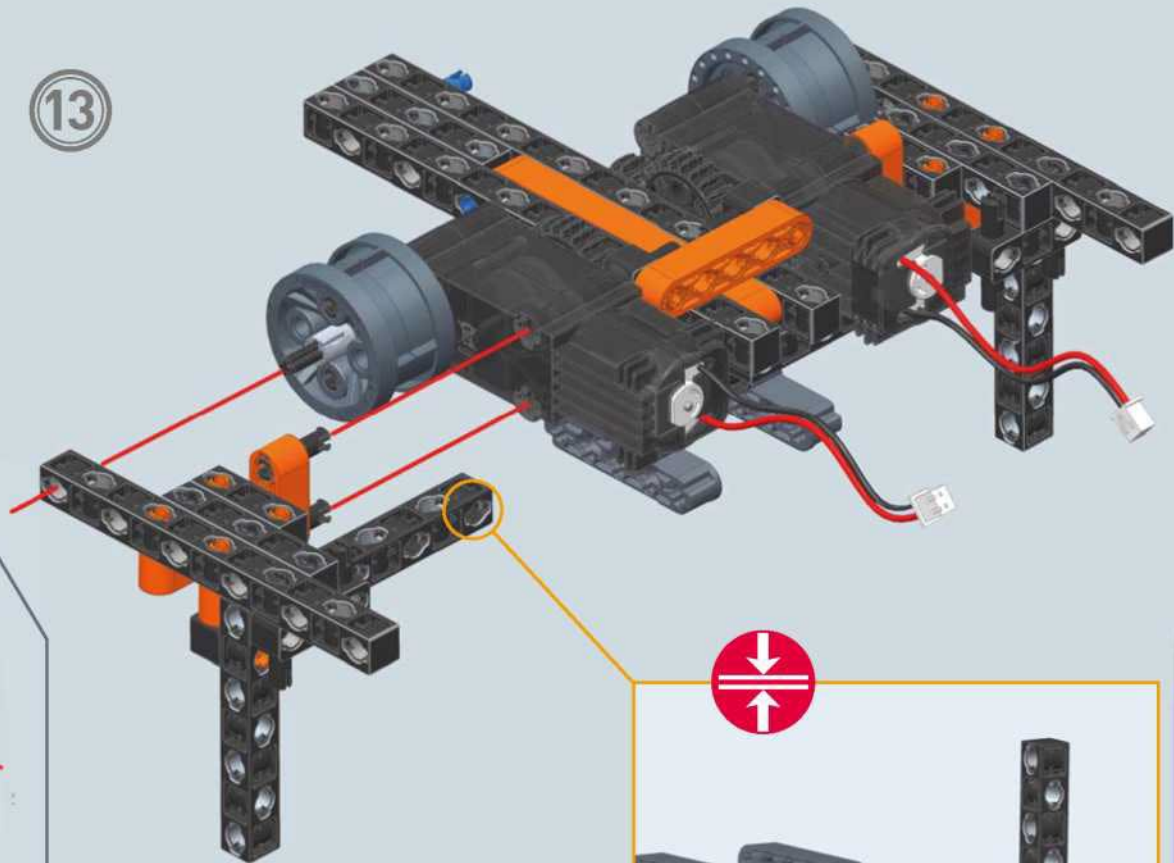

Připojte dvojitou tyč pomocí 9
otvory na oranžový nýt.

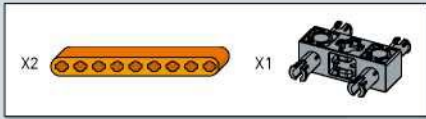

14

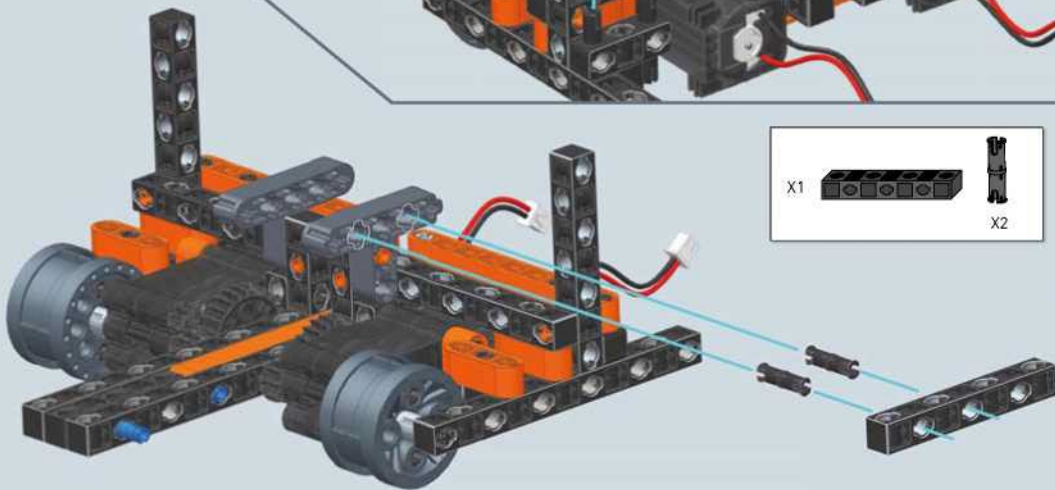
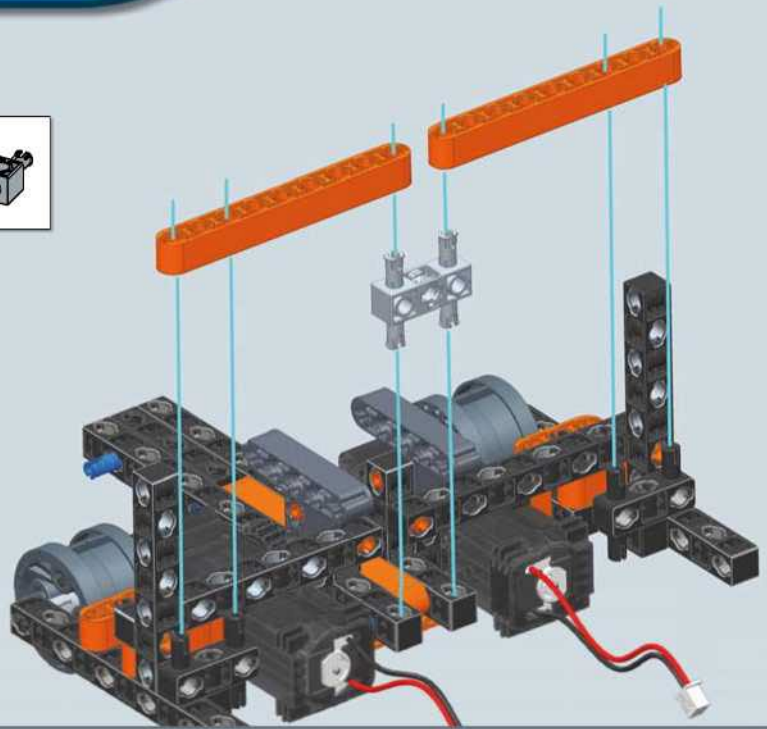

15

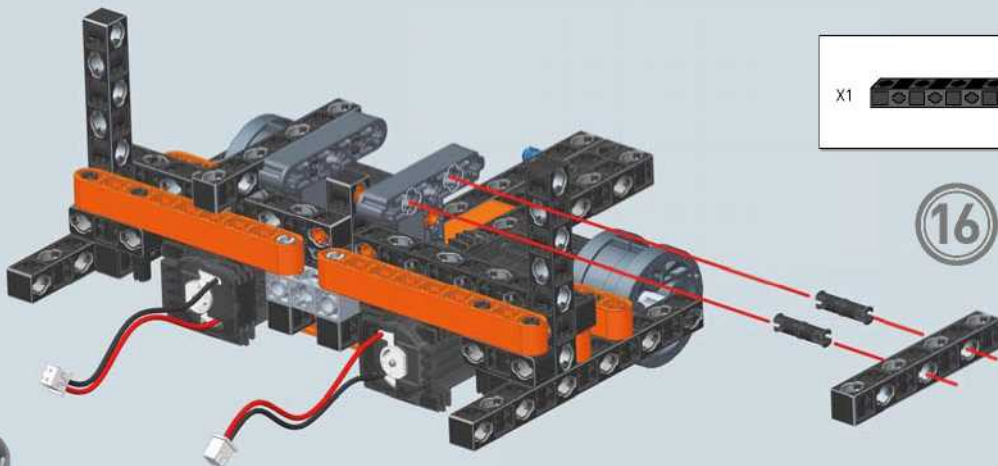

16

17

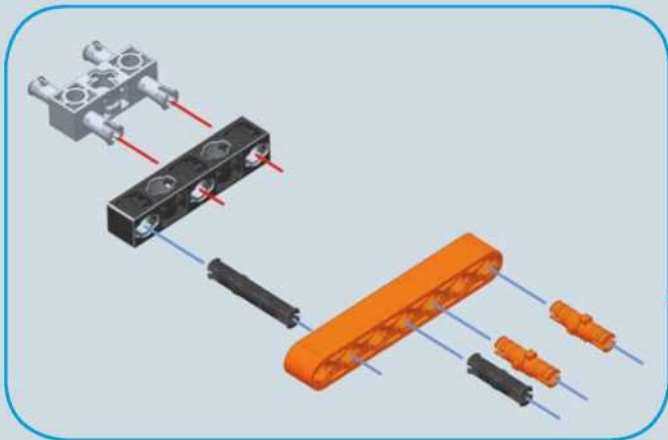
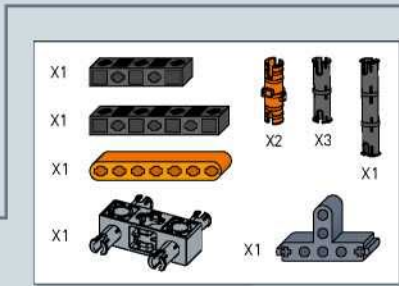
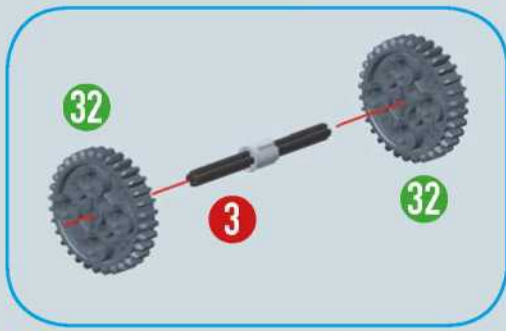
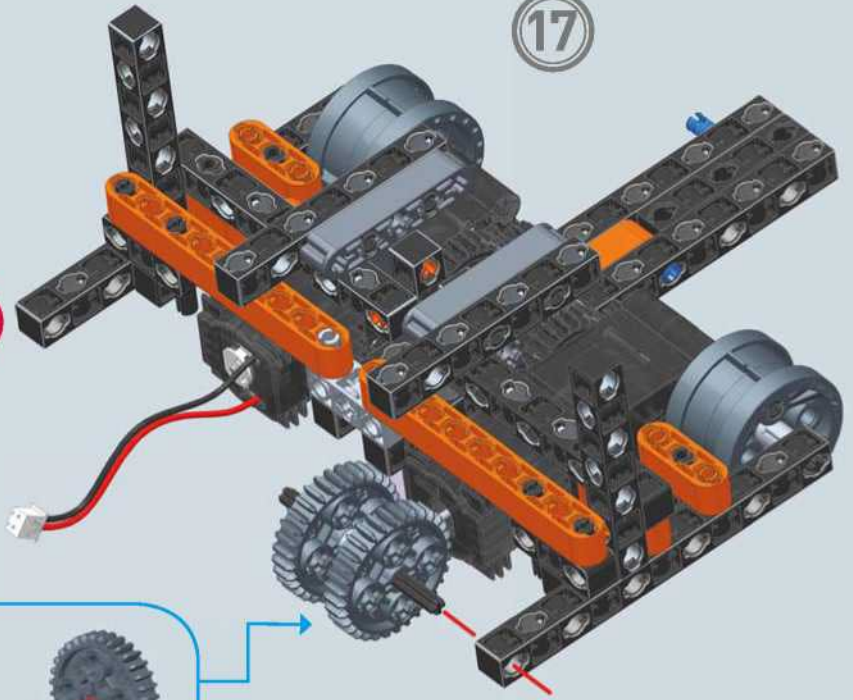

18

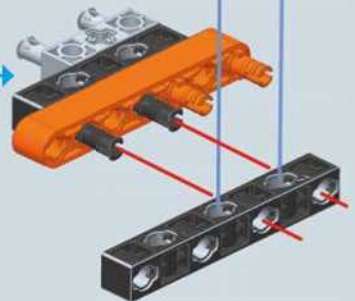

19

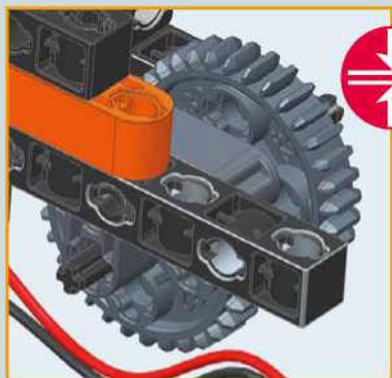

Vložte tyč 3 do nejvzdálenějšího otvoru ve tvaru T na tyči.

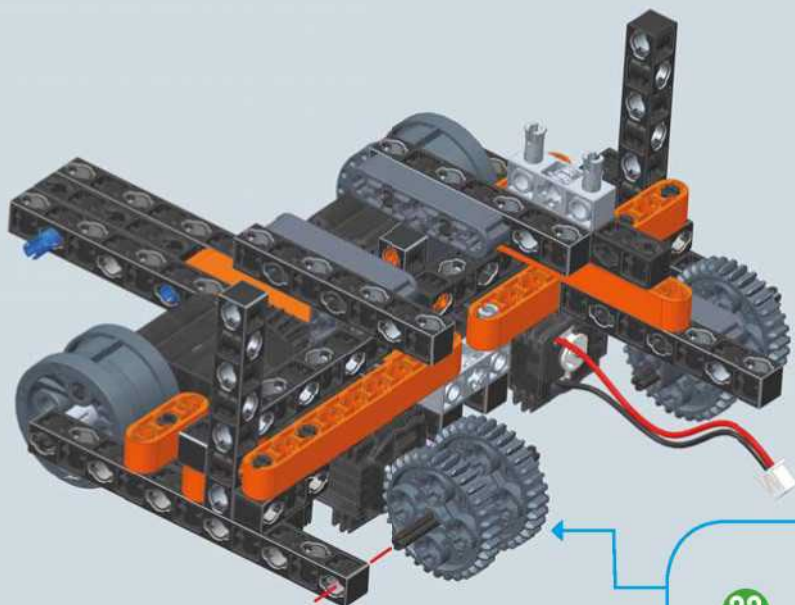
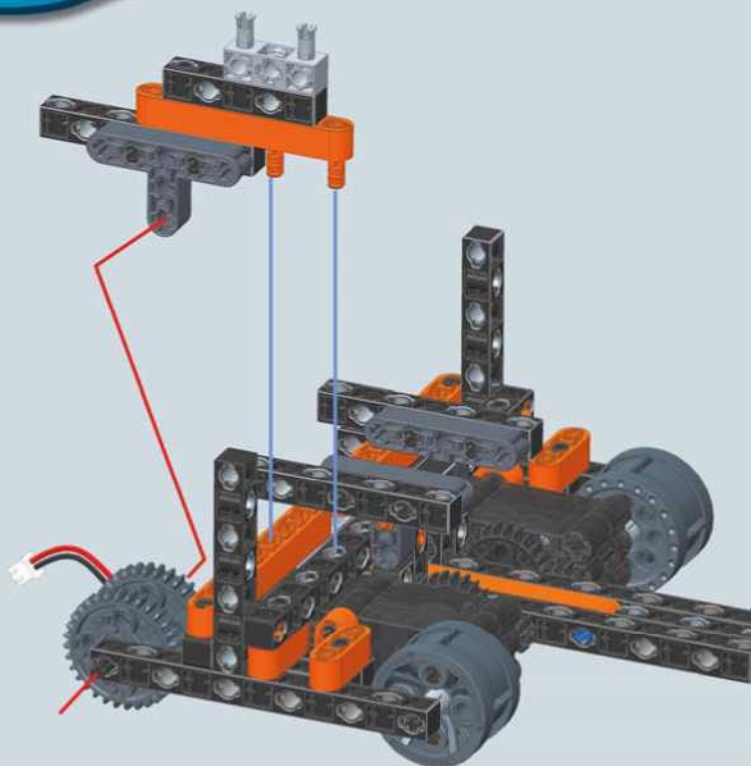

20

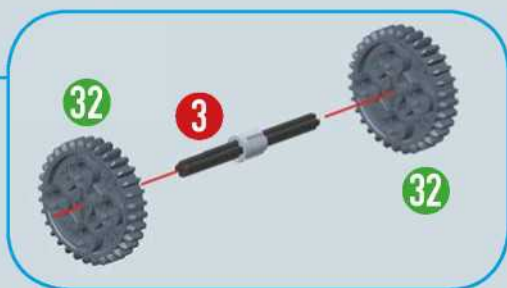

21

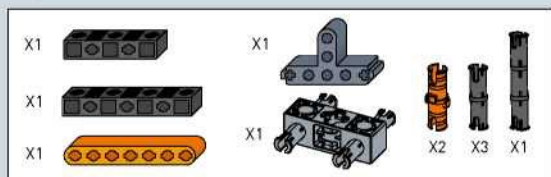
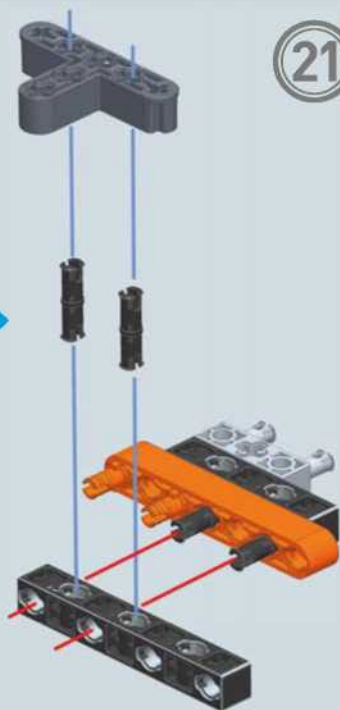
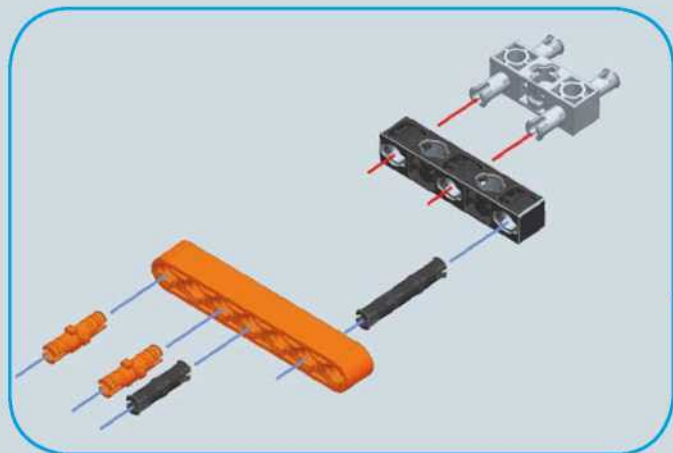

22

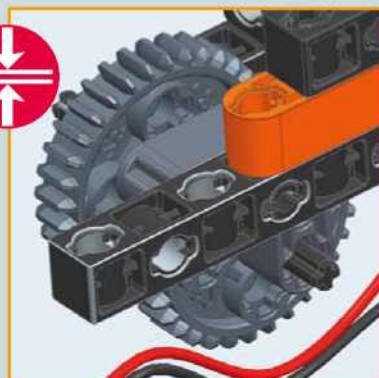
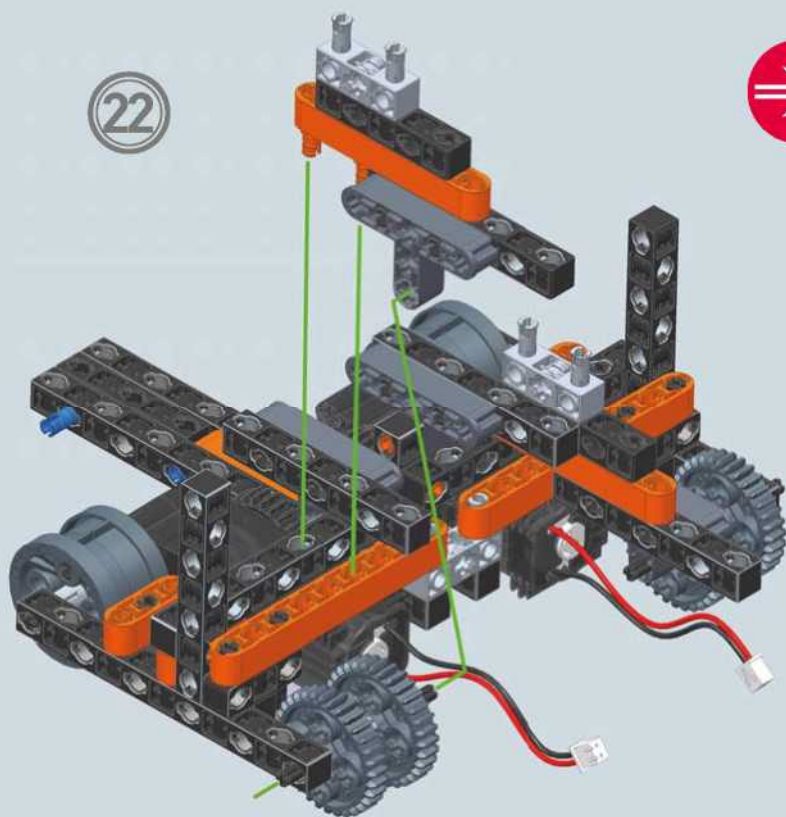

Vložte tyč **M** do nejbližšího otvoru tyče **T**.

11



Zatlačte nýty tak daleko, aby ste spojili obe čierne tyče.

23

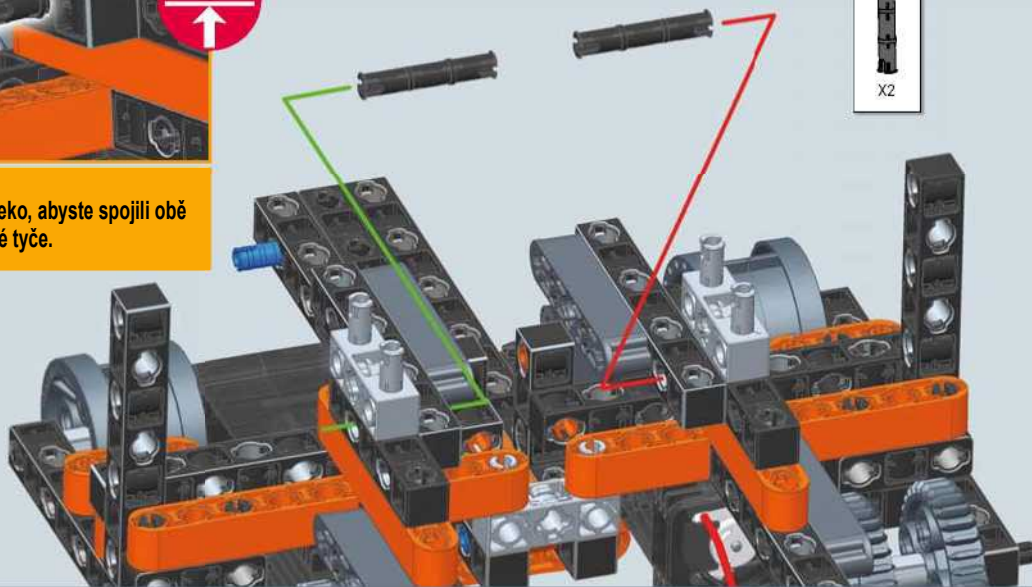

18

18



3

X2

24

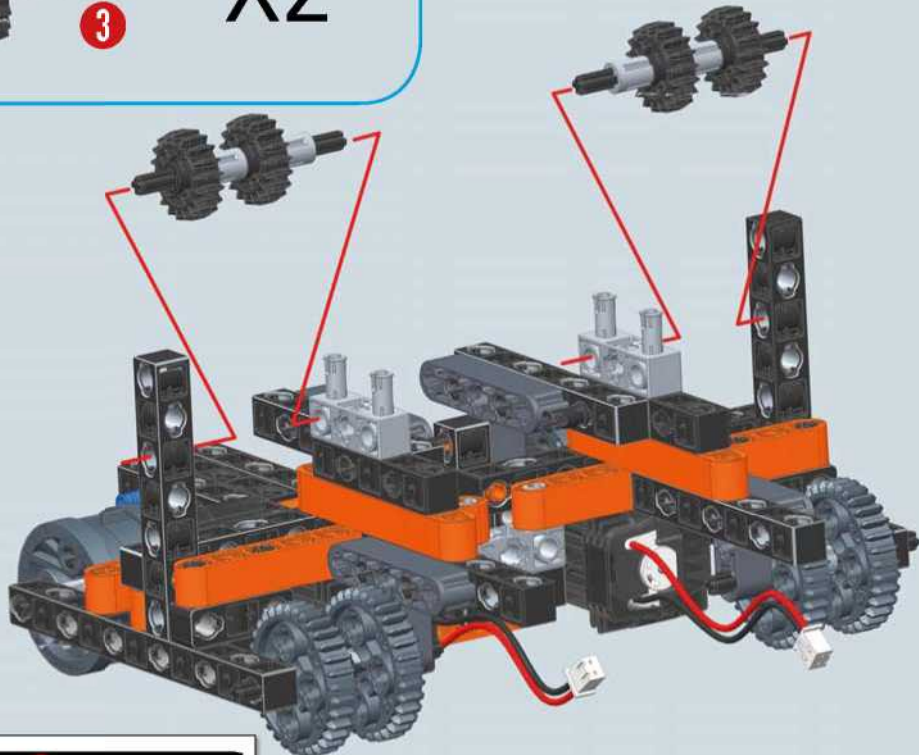

12

1:1



13

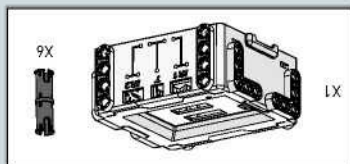

26

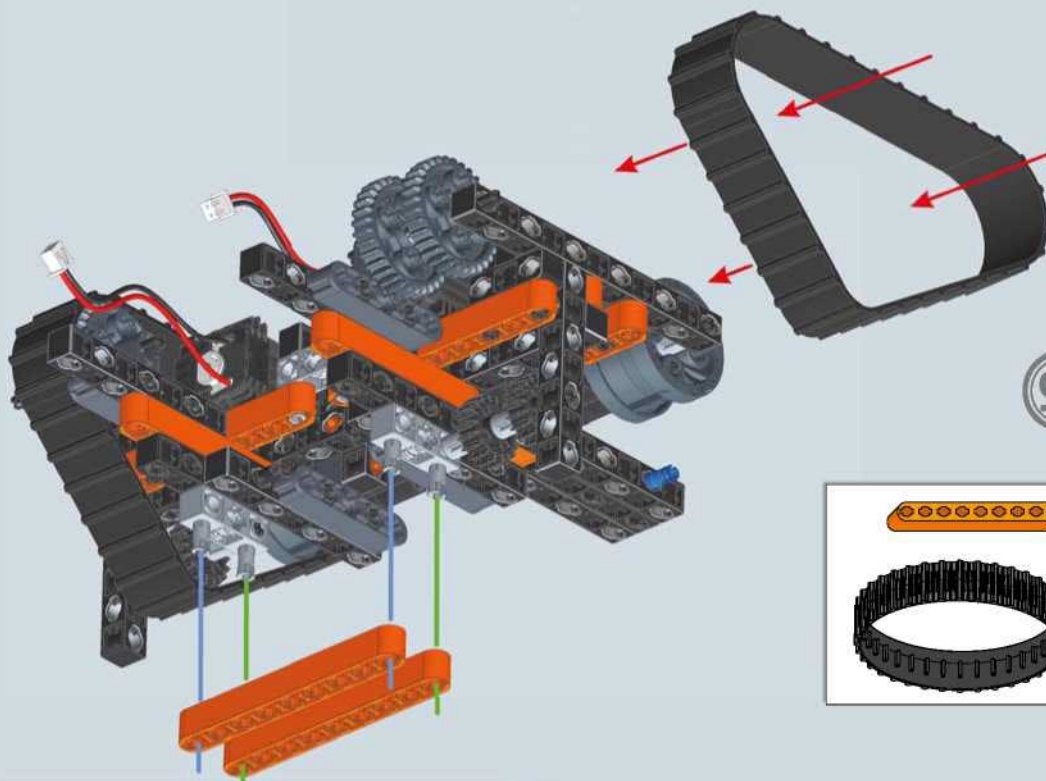
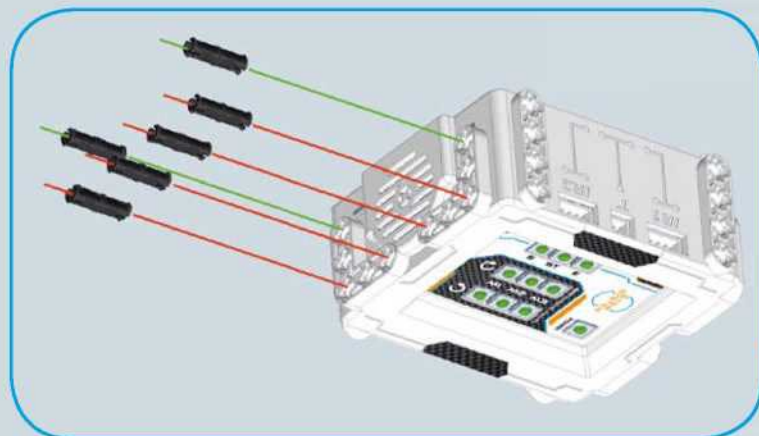

25



PŘIPOJENÍ MOTORŮ NA CENTRAL

Umístěte model podle obrázku
a připojte motor vlevo k portu
M1 a motor vpravo k portu M2.

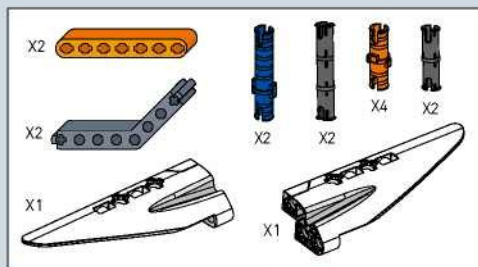
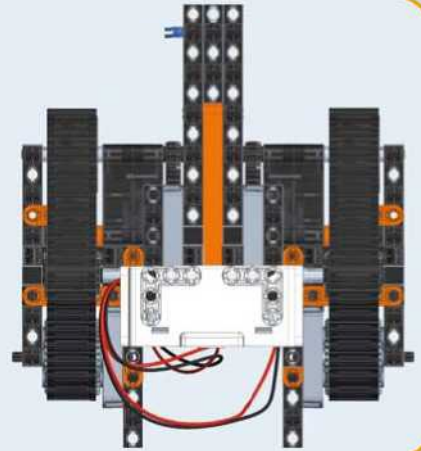
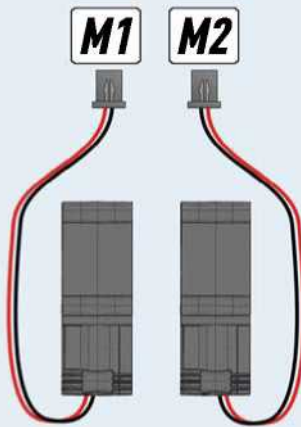

27

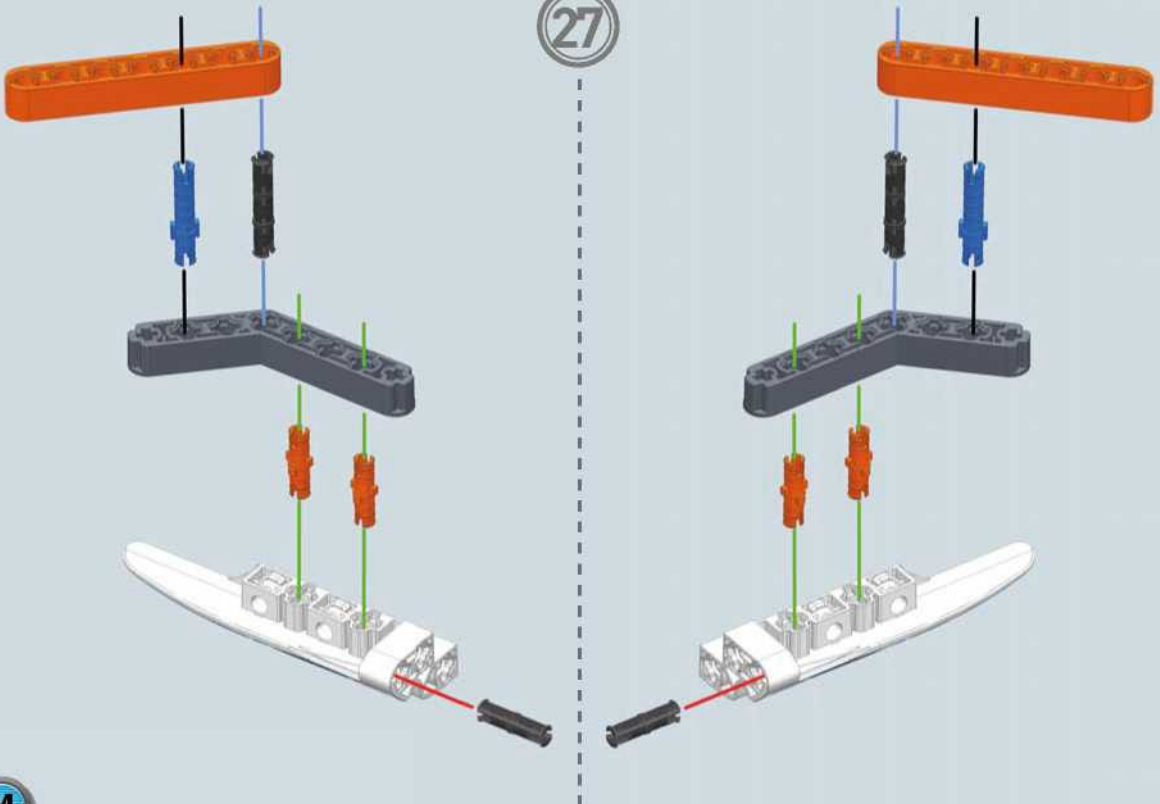

28

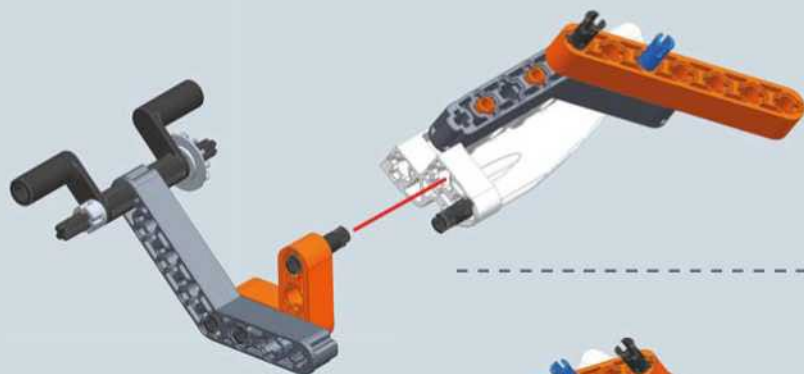
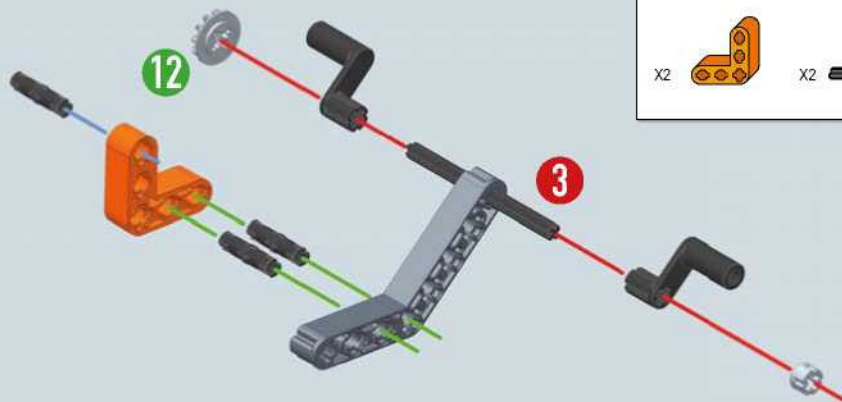
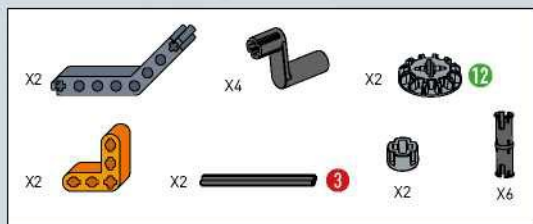
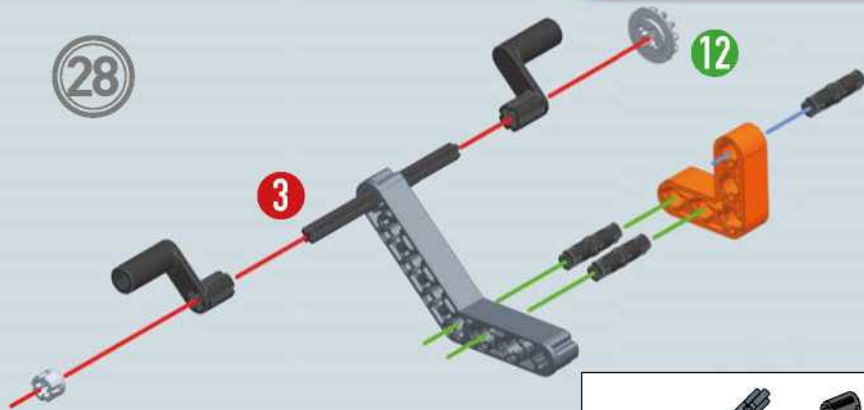

29

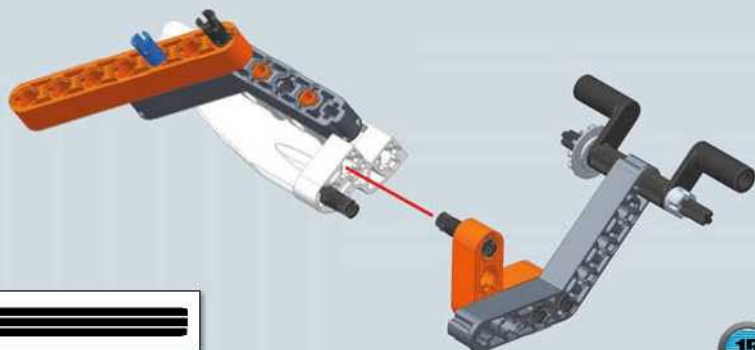

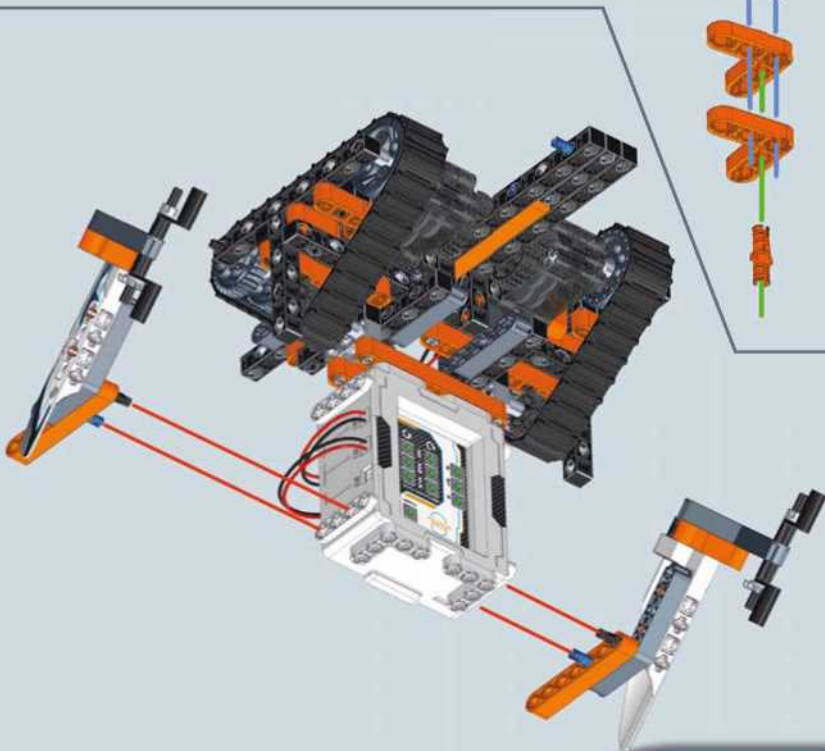
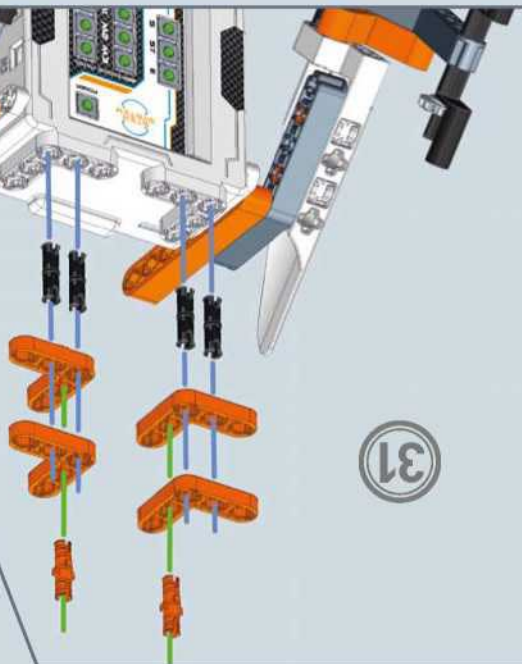
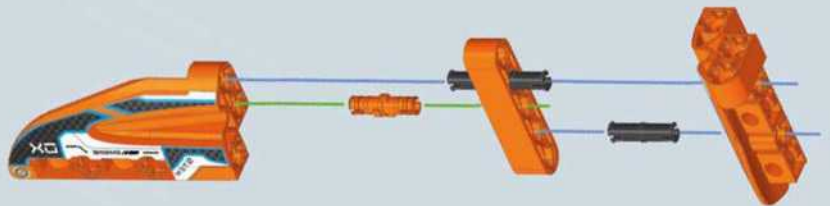
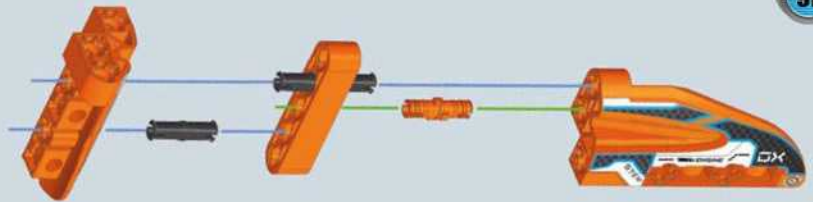
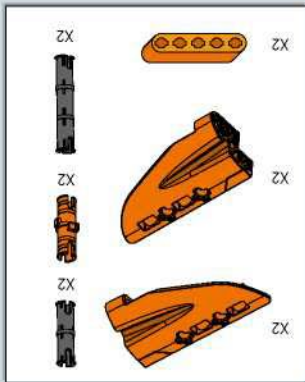

33

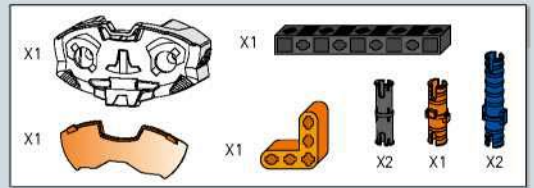
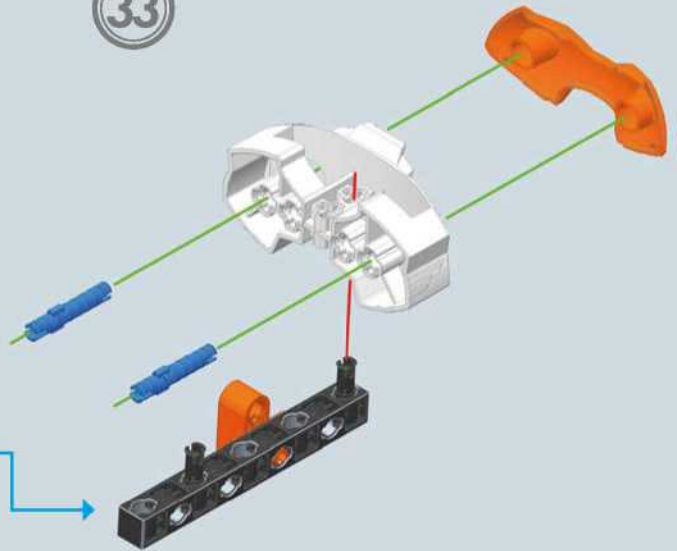
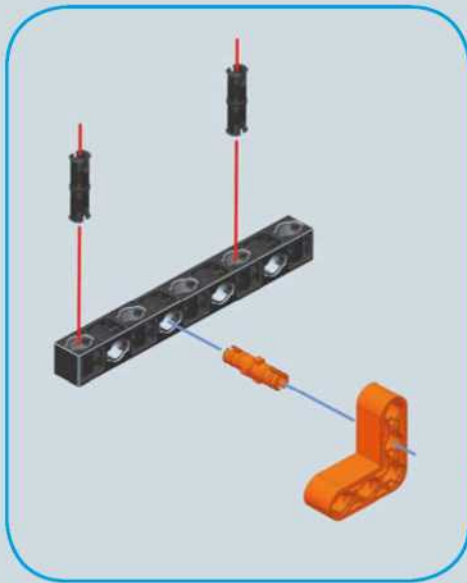

34

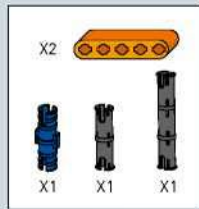
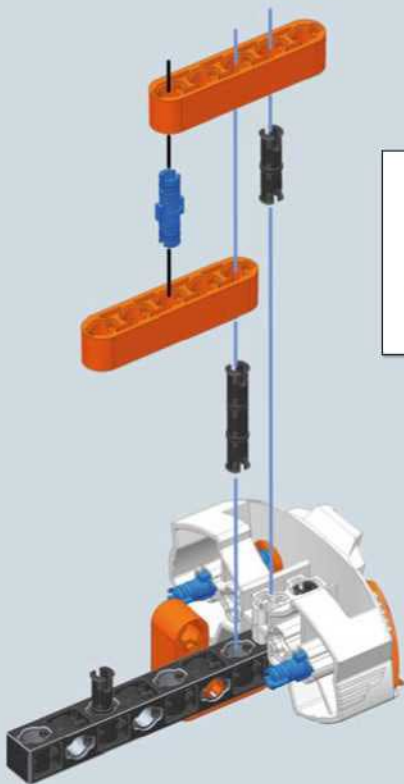

35

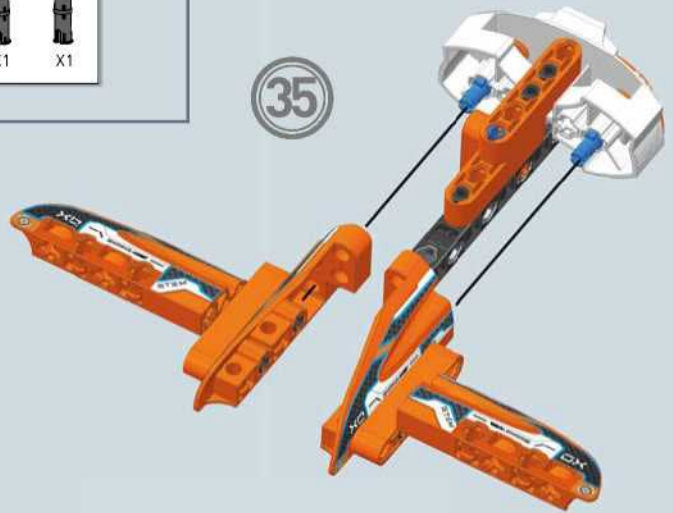

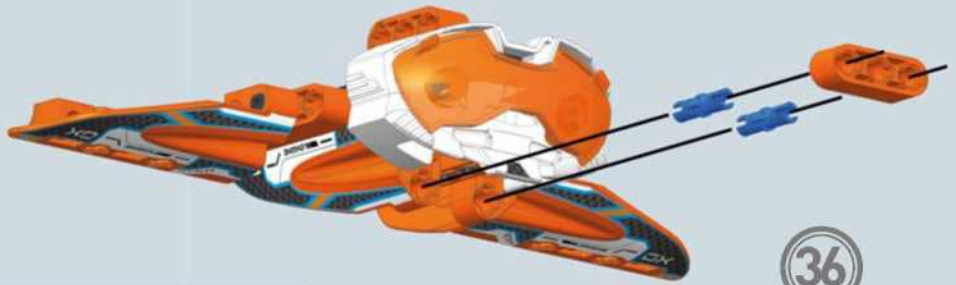
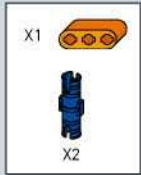

36

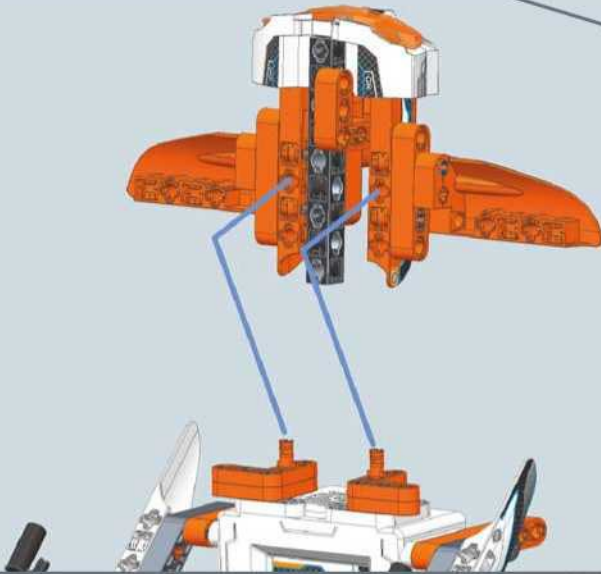

37

38

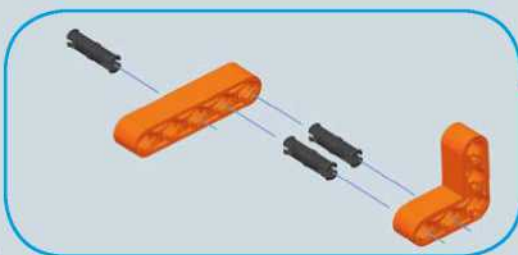
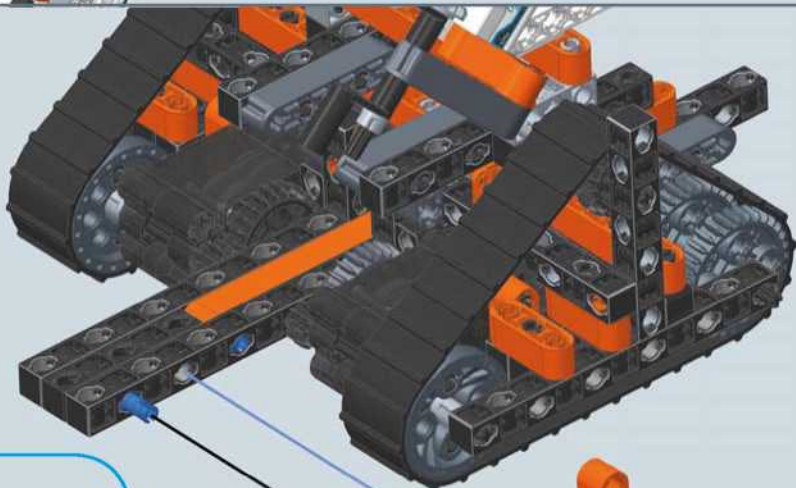
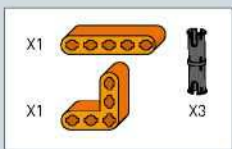

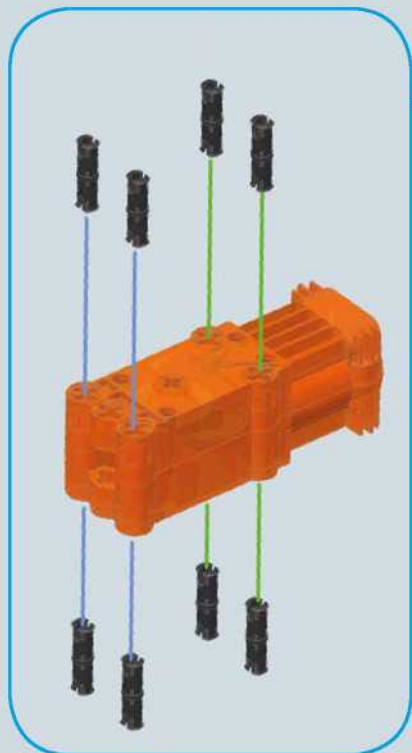

39

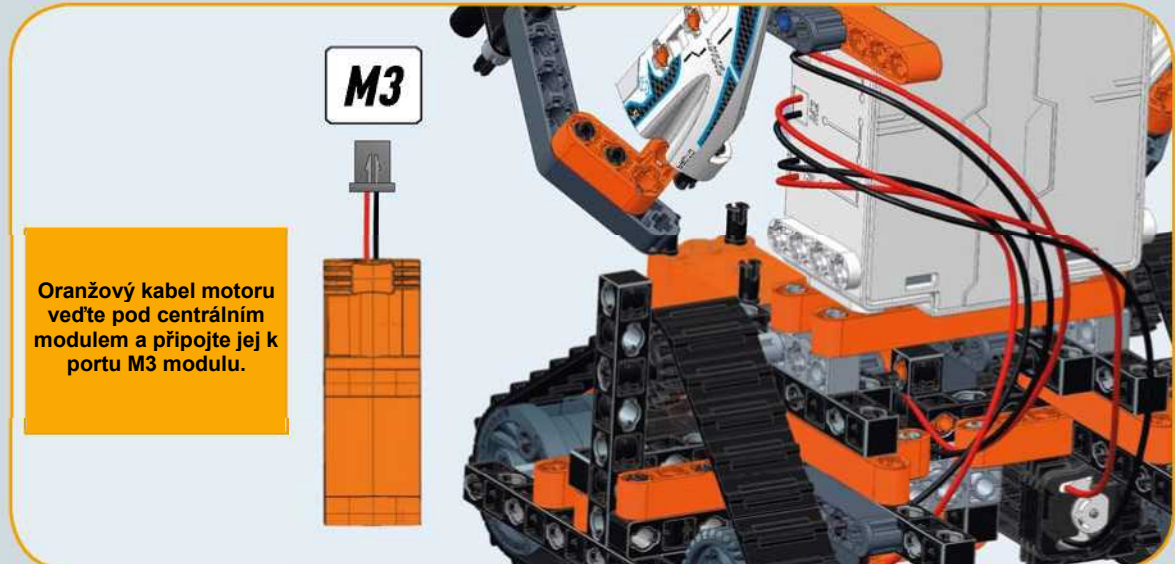
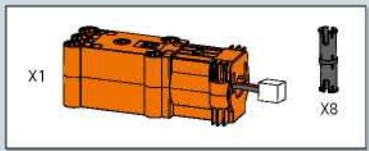
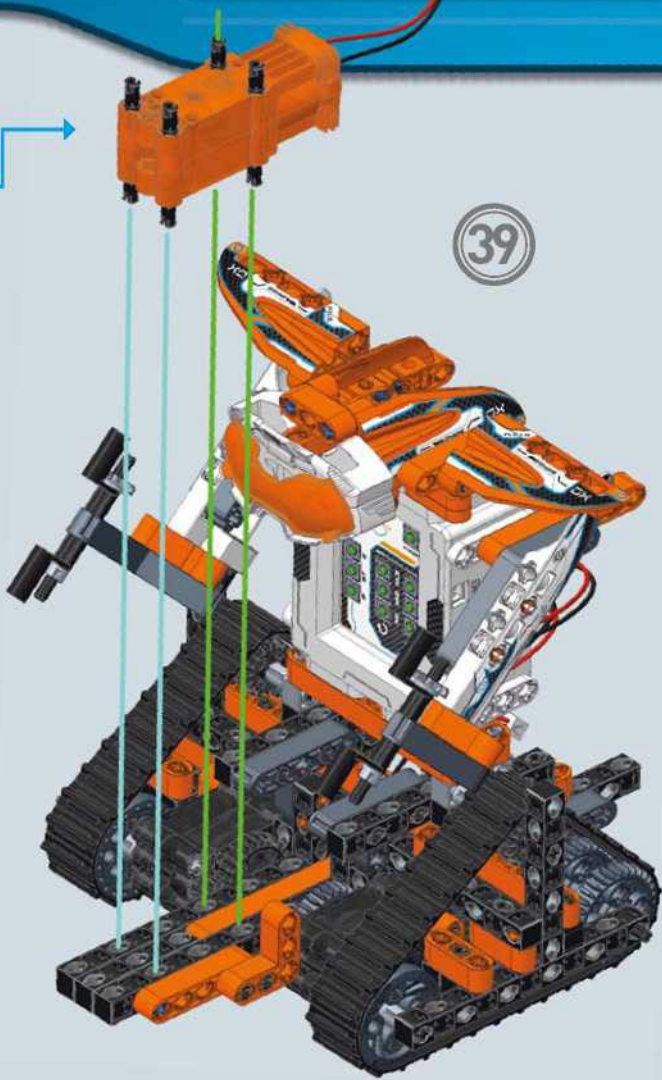

M3

Oranžový kabel motoru ved'te pod centrálním modulem a připojte jej k portu M3 modulu.

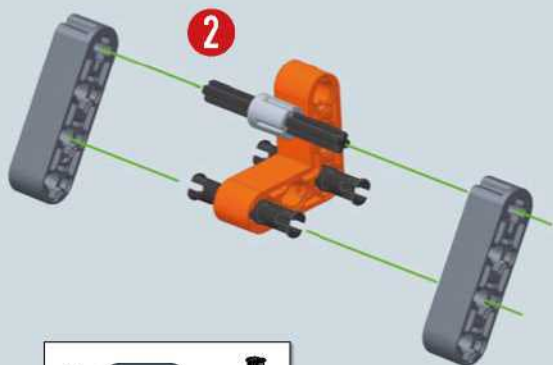

2

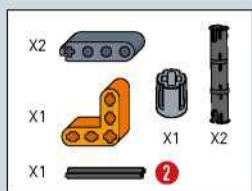

40

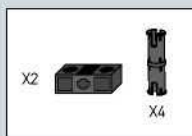

41

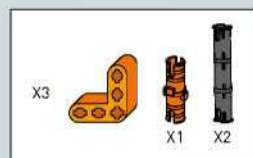
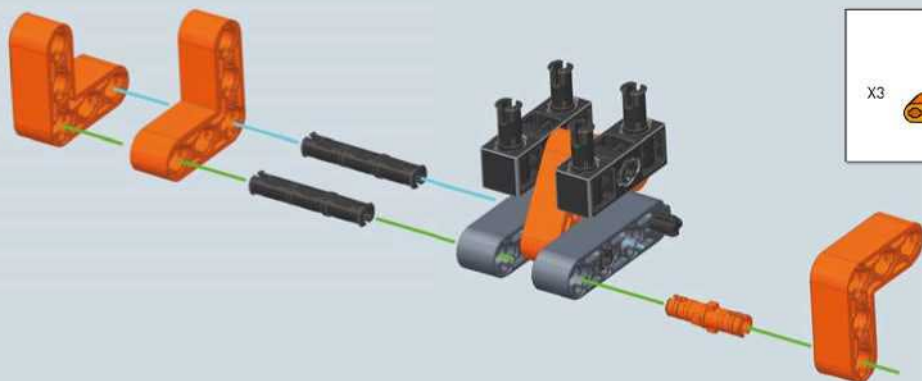
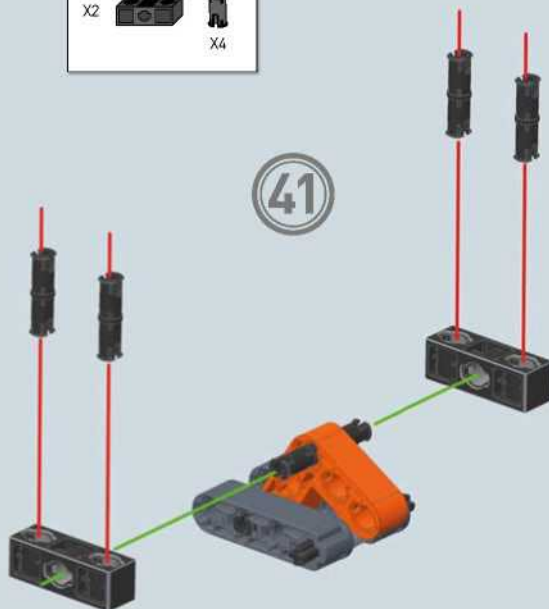

42

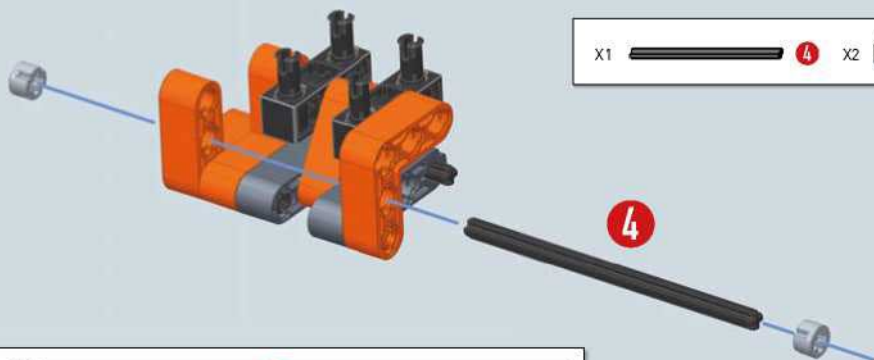

43

4



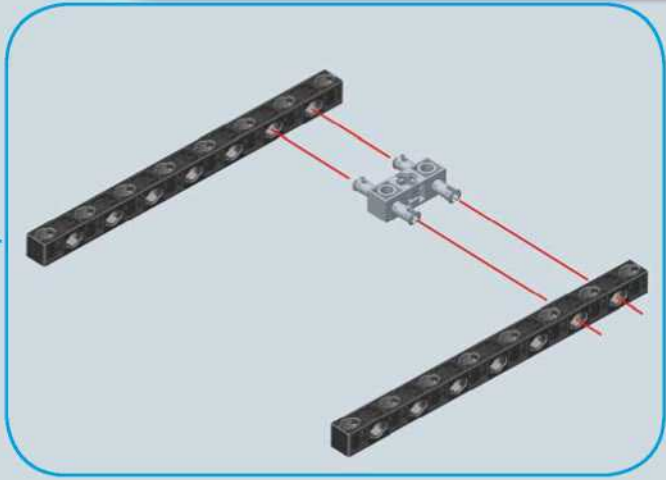
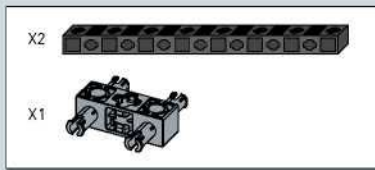

44

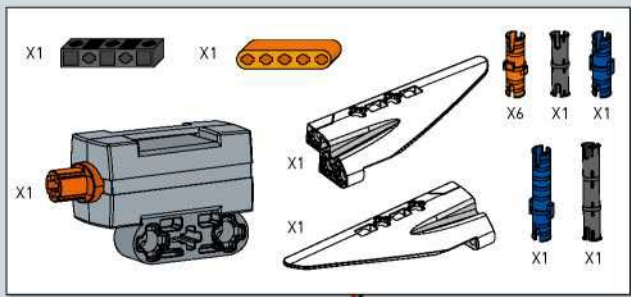
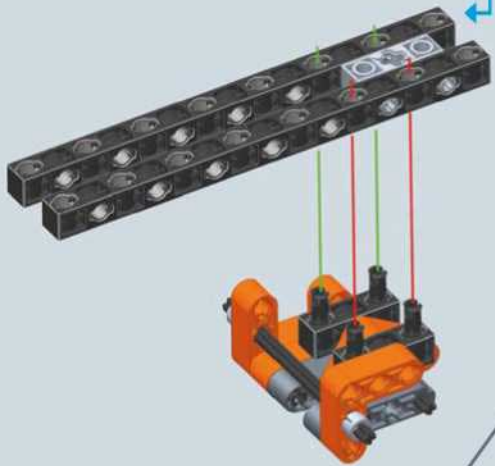

45

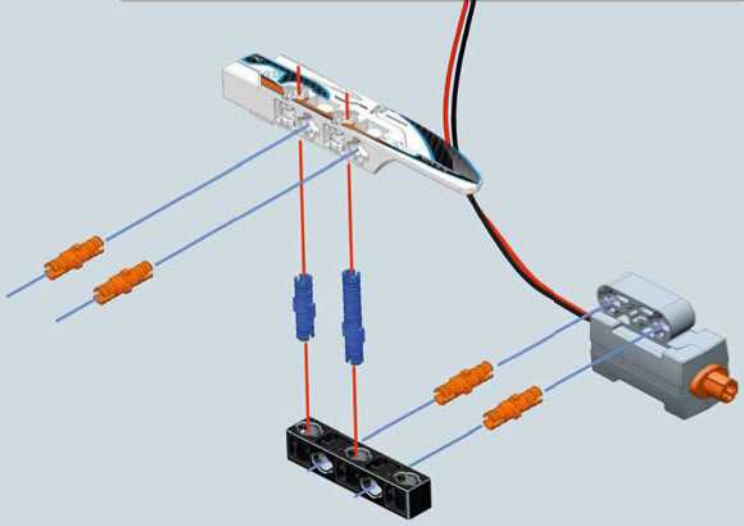
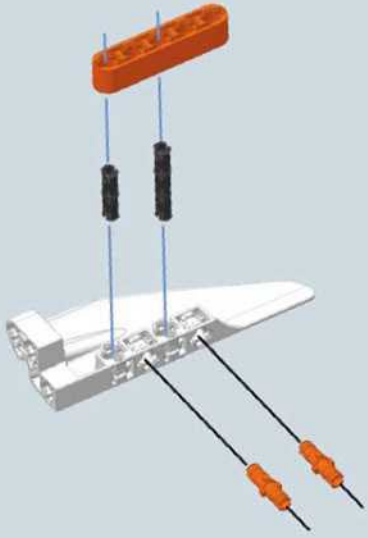

21

46

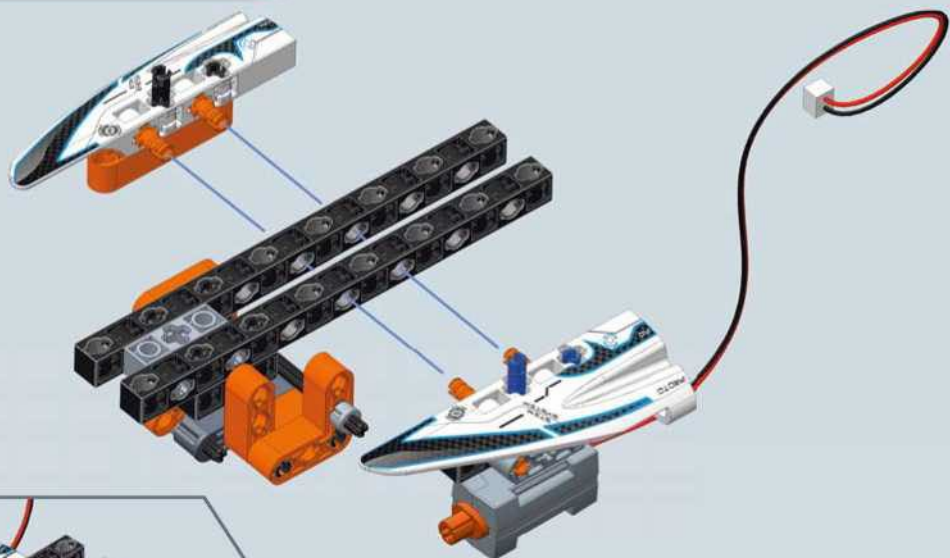

47

Zkontrolujte, zda jsou oba bloky správně připojeny.

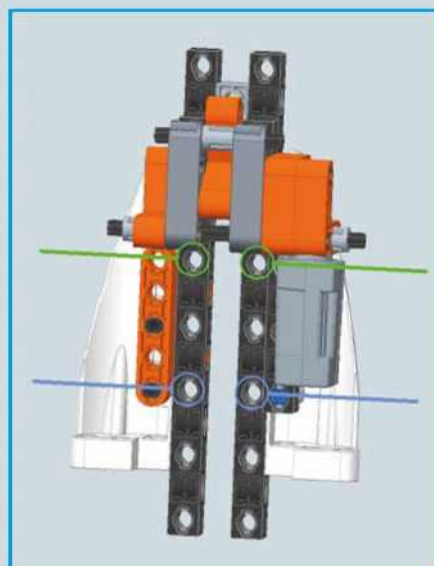

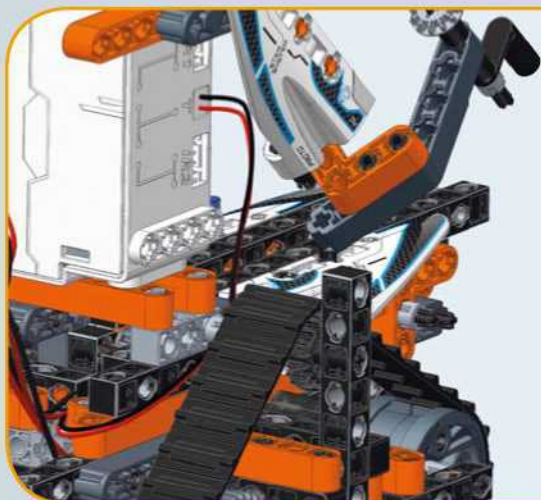

T

**PŘIPOJENÍ SENZORU NA
CENTRÁLNÍ MODUL**

Protáhněte kabel dotykového
senzoru pod centrální
jednotkou a připojte jej k
portu T.

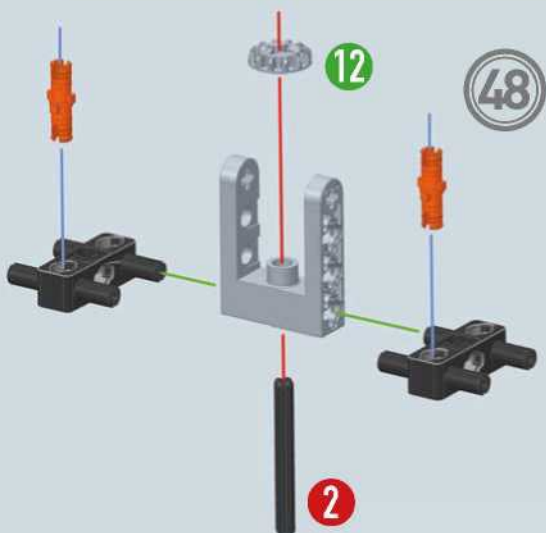

48

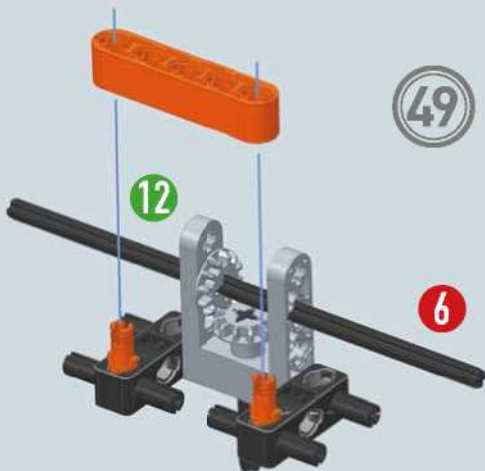
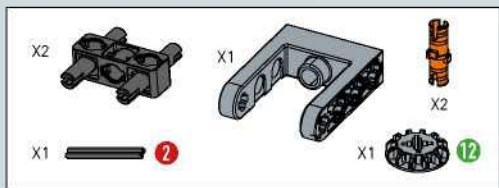

49

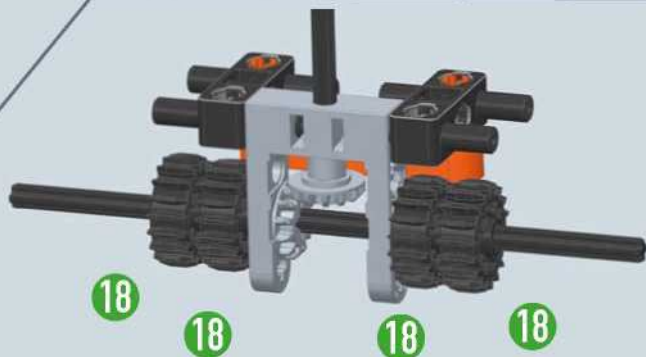

50



24

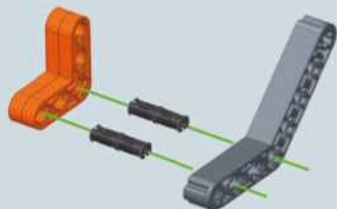

51

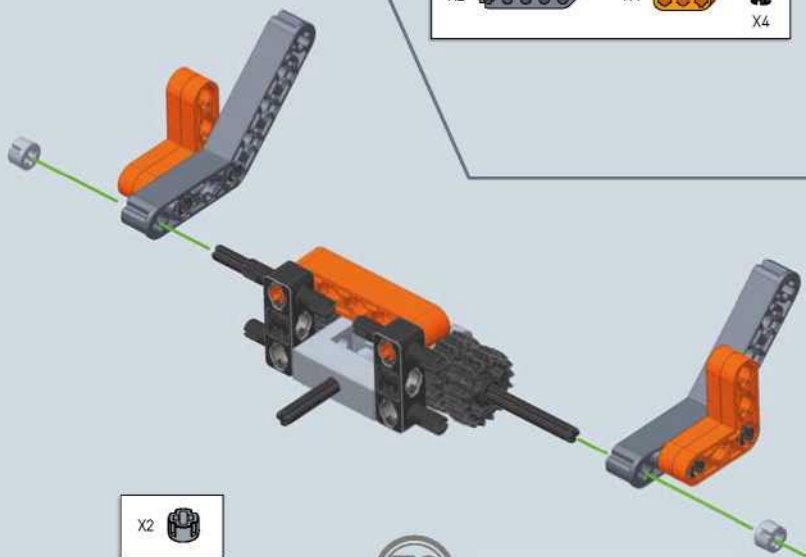
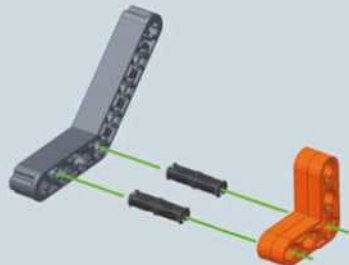





52

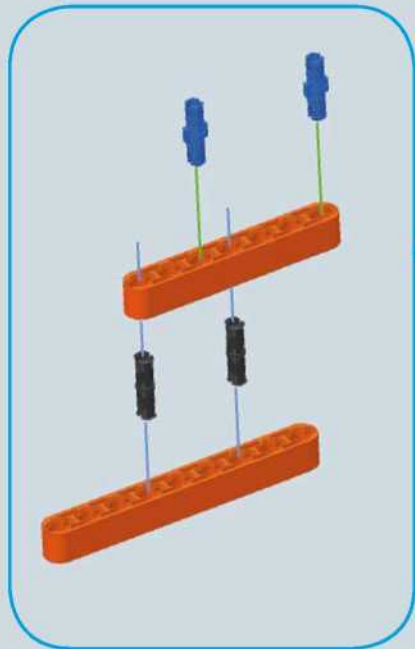

53



Vložení tyče 2 do křížového otvoru motoru S1.

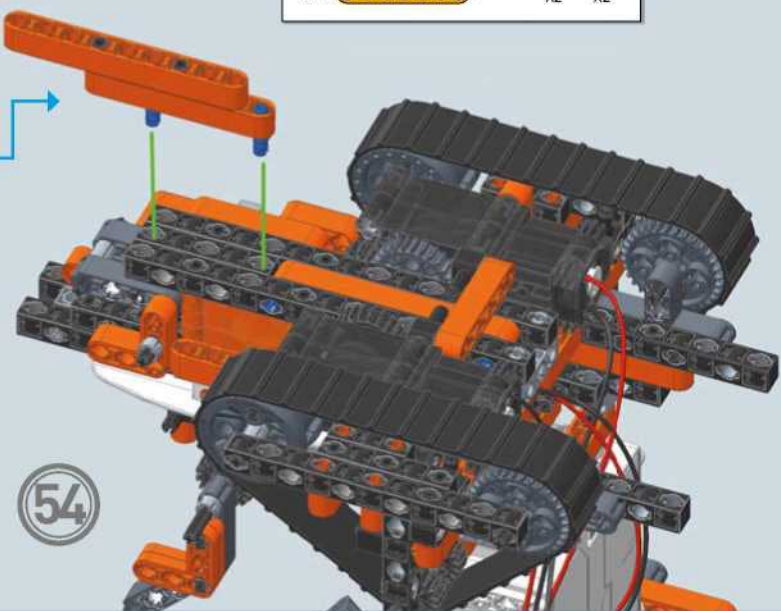

- X1 
- X1 
- X2 
- X2 

54

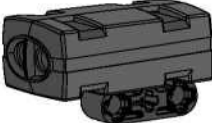

- X1 
- X2 

55

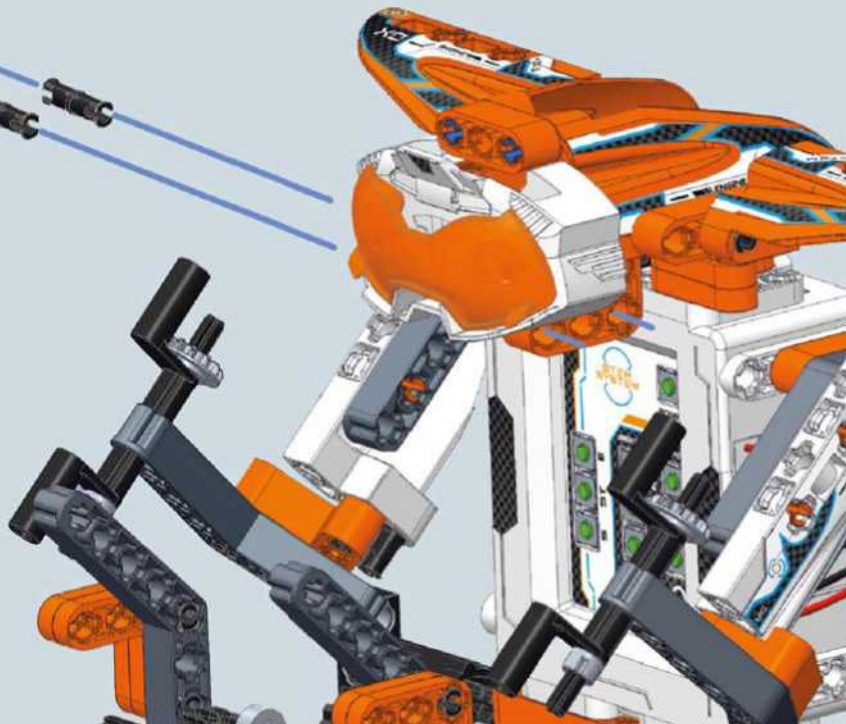

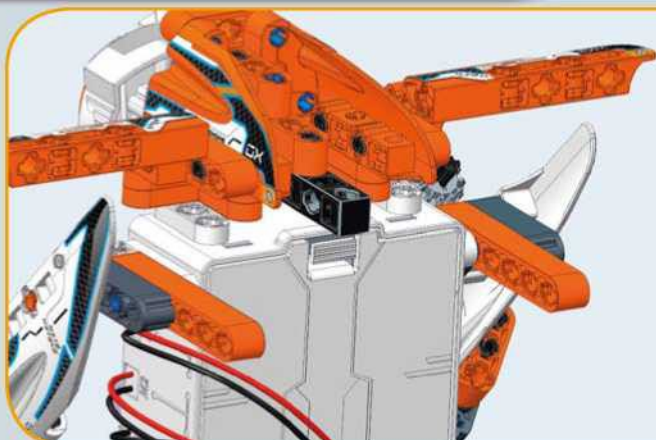

IR1

PŘIPOJENÍ SENZORU NA CENTRAL

Vyved'te kabel IR senzoru zpoza hlavy a připojte jej kportu IR1.

56

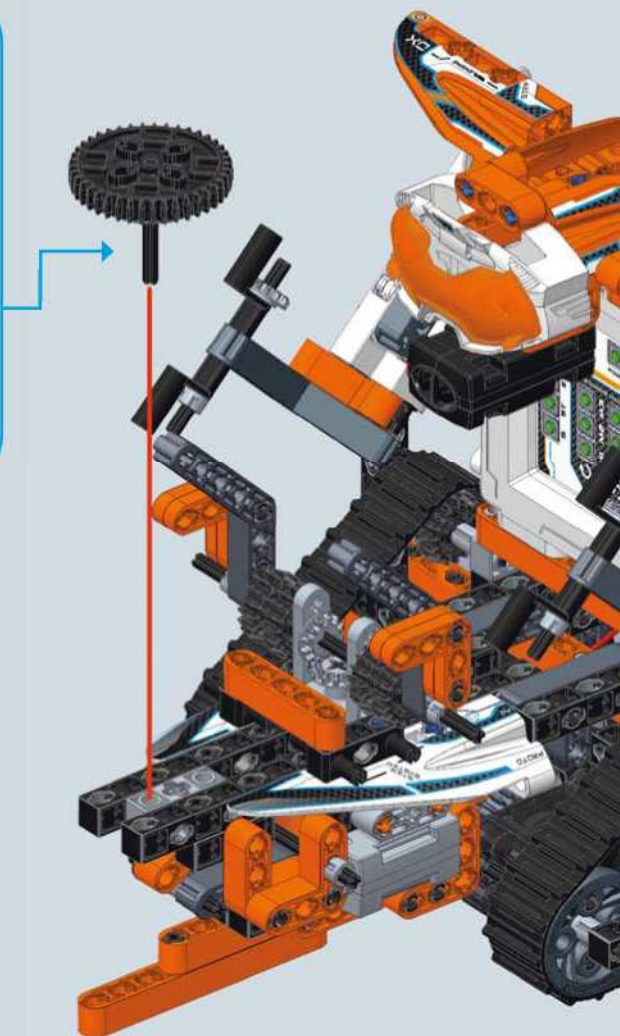
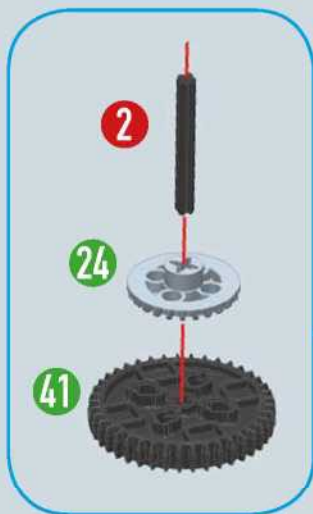

DOKONČENÝ MODEL



Strážce

Montáž

Počínaje krokem 37 strážního robota pokračujte podle níže uvedených pokynů a dokončete strážního robota.



- X2
- X1
- X2
- X1
- X4

1

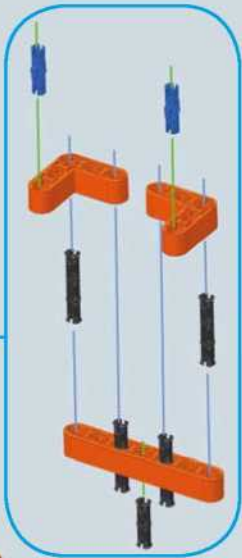

2

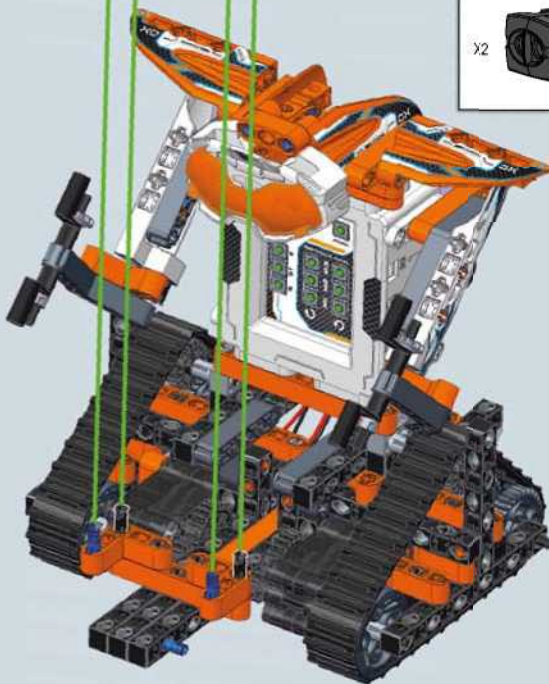
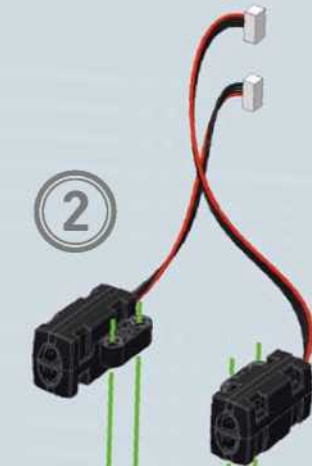

PŘIPOJENÍ SENZORŮ NA CENTRAL

Připojte IR senzor vlevo pomocí portu IR1 a IR senzor vpravo pomocí portu IR2.

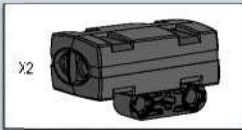
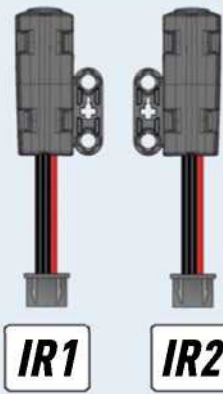

DOKONČENÝ MODEL

