

coding  
lab → → ↑

# RoboMaker<sup>®</sup>

výuková laboratoř robotiky

pro

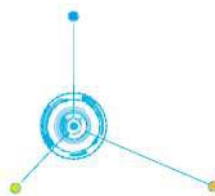

## X2•SPIDER

LEGO® MINDSPRINGER™ 2 IN 1 ROBOTIC KIT

Vědecké poradenství v  
oblasti kódování a  
blokového  
programování: Prof.  
Alessandro Bogliolo

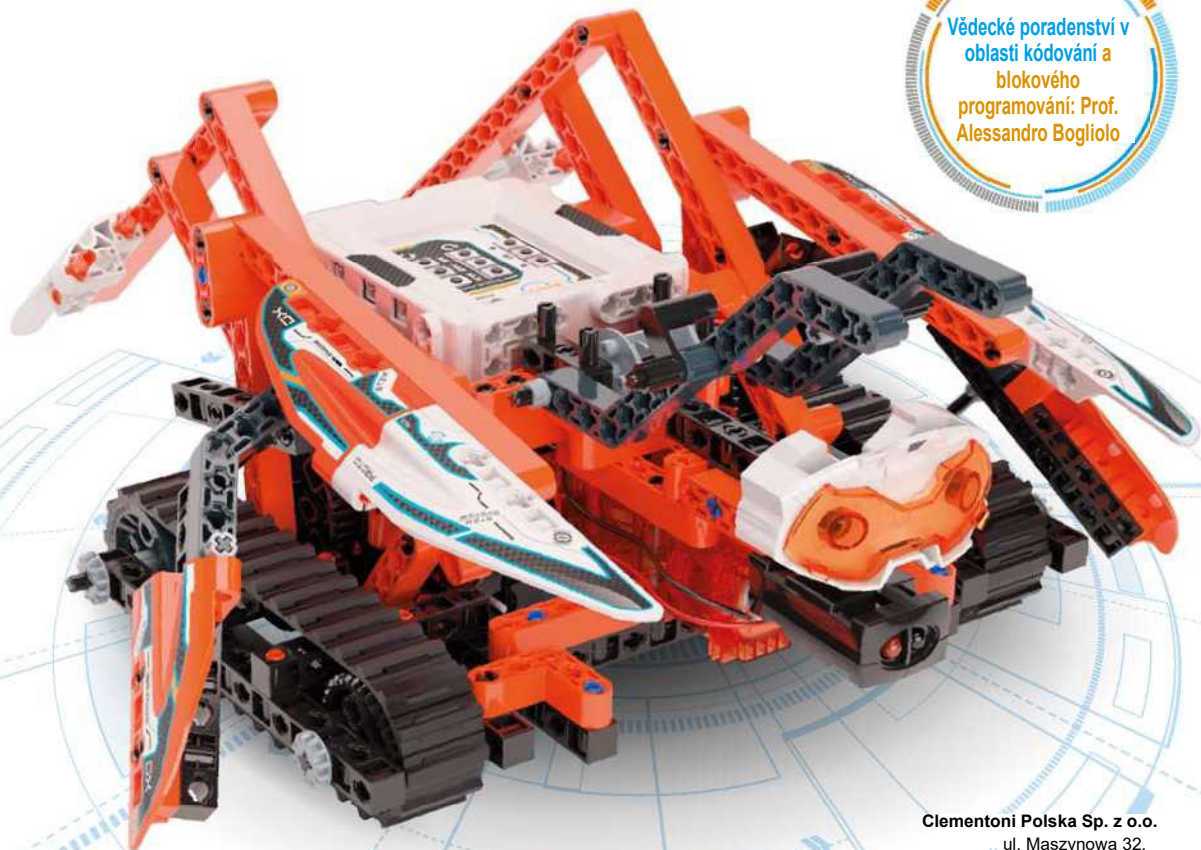

Clementoni Polska Sp. z o.o.  
ul. Maszynowa 32,  
80-298 Gdansk, Polska Tel.: +48  
58 3432882  
poland@clementoni.com

**PRODUCENT:**  
Clementoni S.p.A.  
Zona Industriale Fontenoce s.n.c.  
62019 Recanati (MC) - Italy Tel.:  
+39 071 75811  
www.clementoni.com

advanced

Přečtěte si pokyny a uschovejte si je pro případnou

 **Clementoni**<sup>®</sup>

# Útěk před predátorem!

Montáž

1

26

26

1

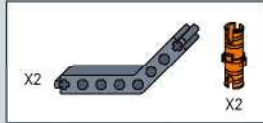

2

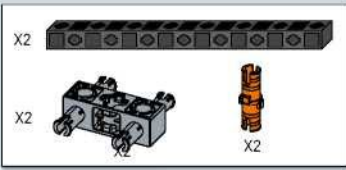
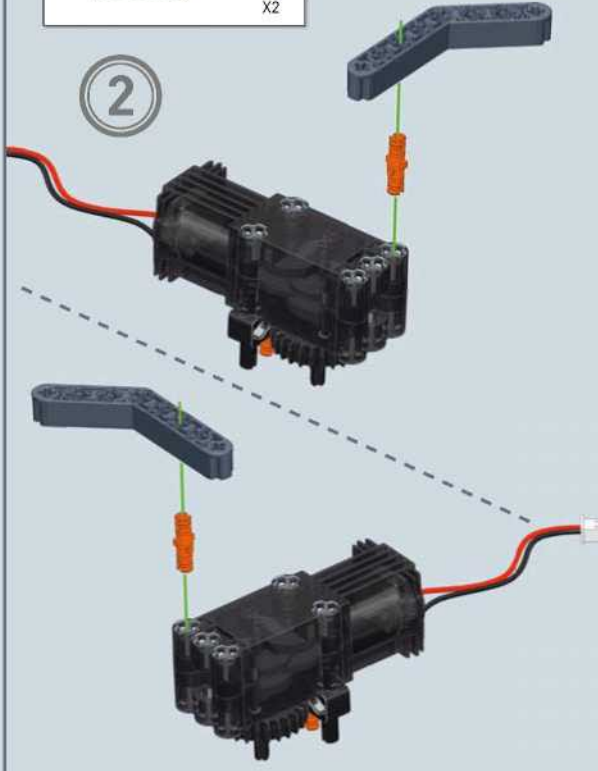
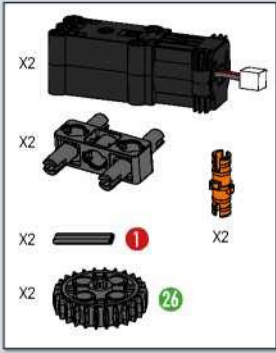

3

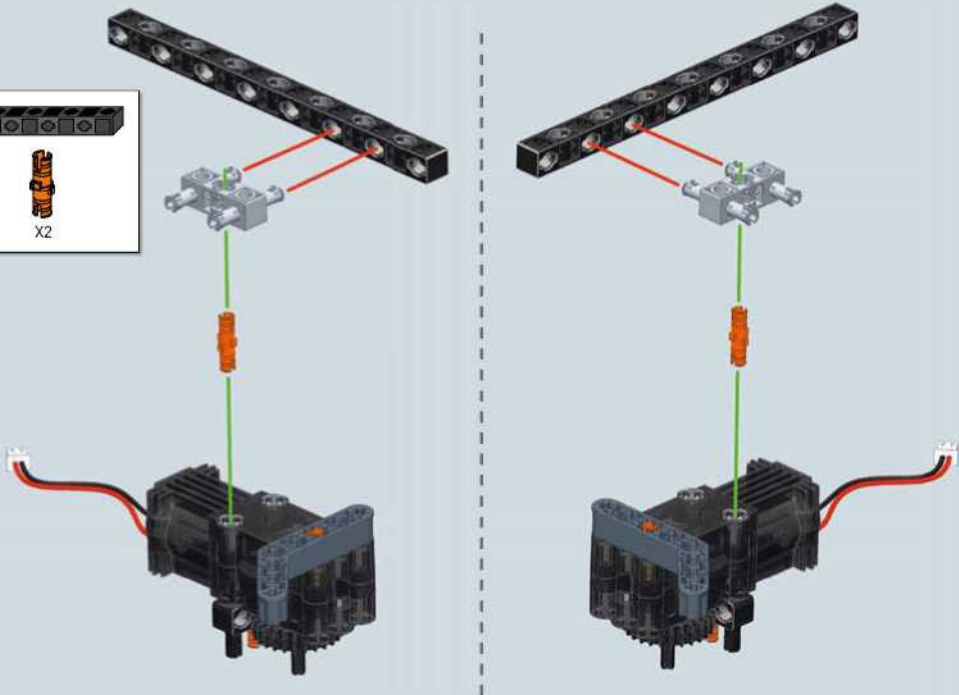

2



4

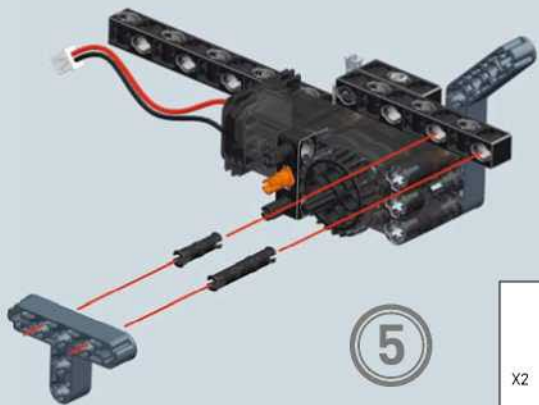
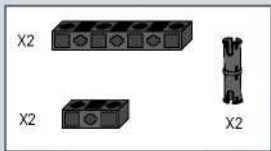

5

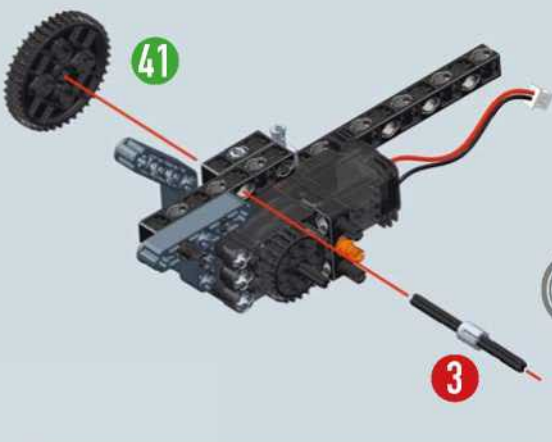
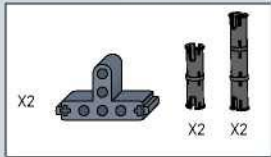
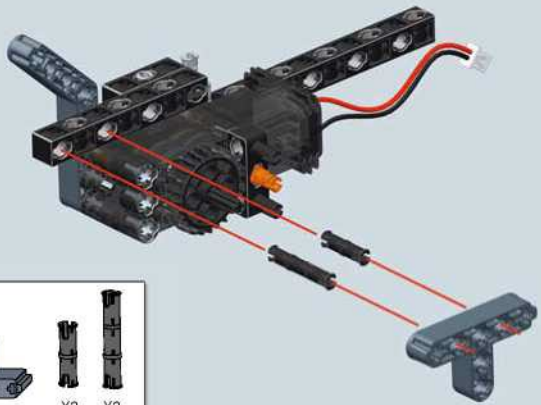

6

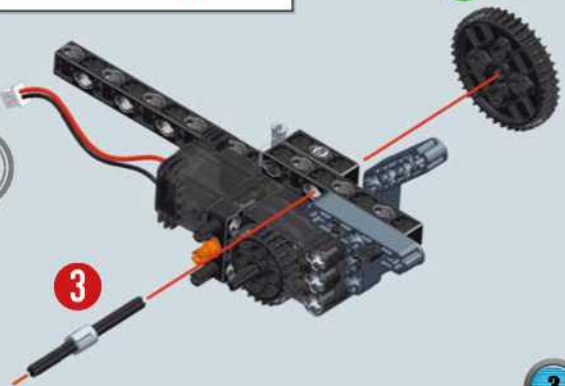
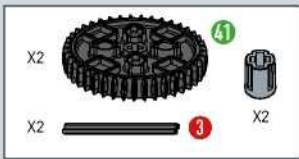

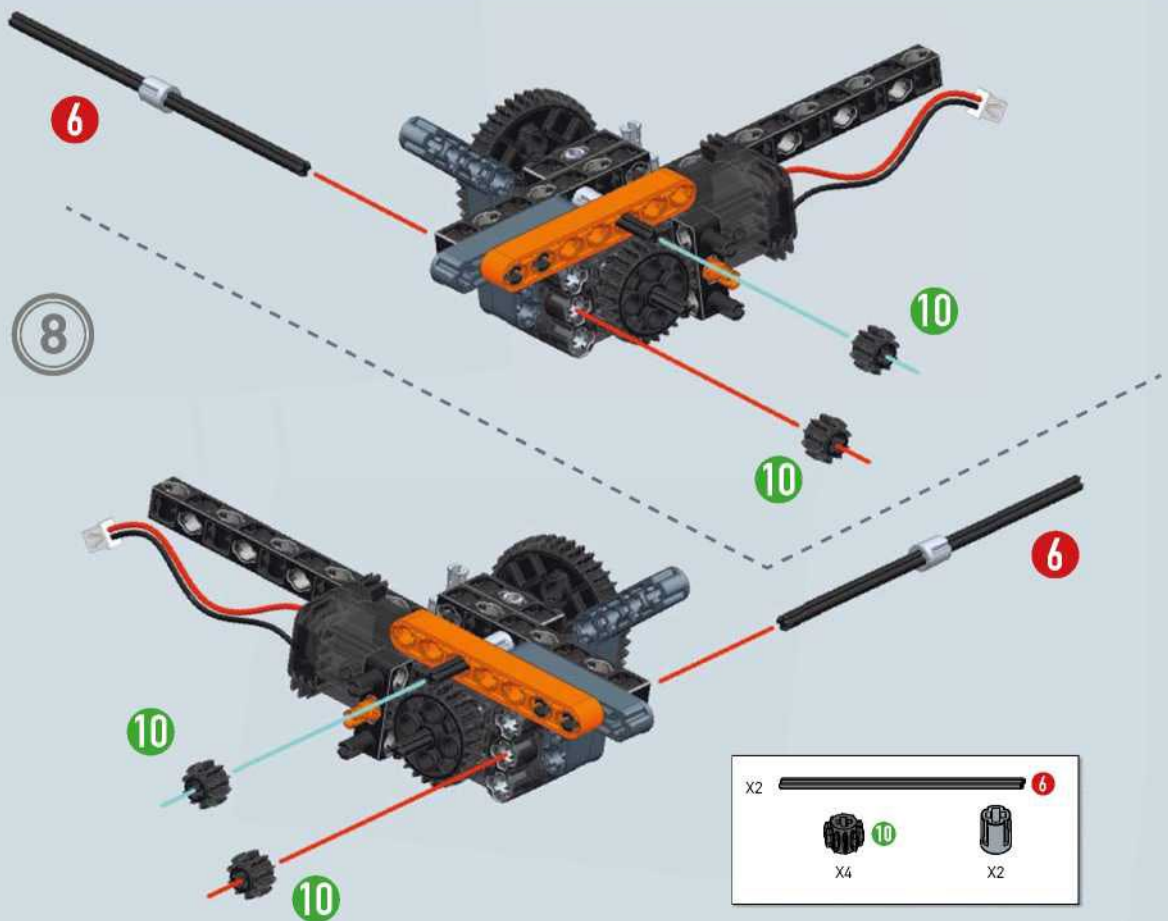
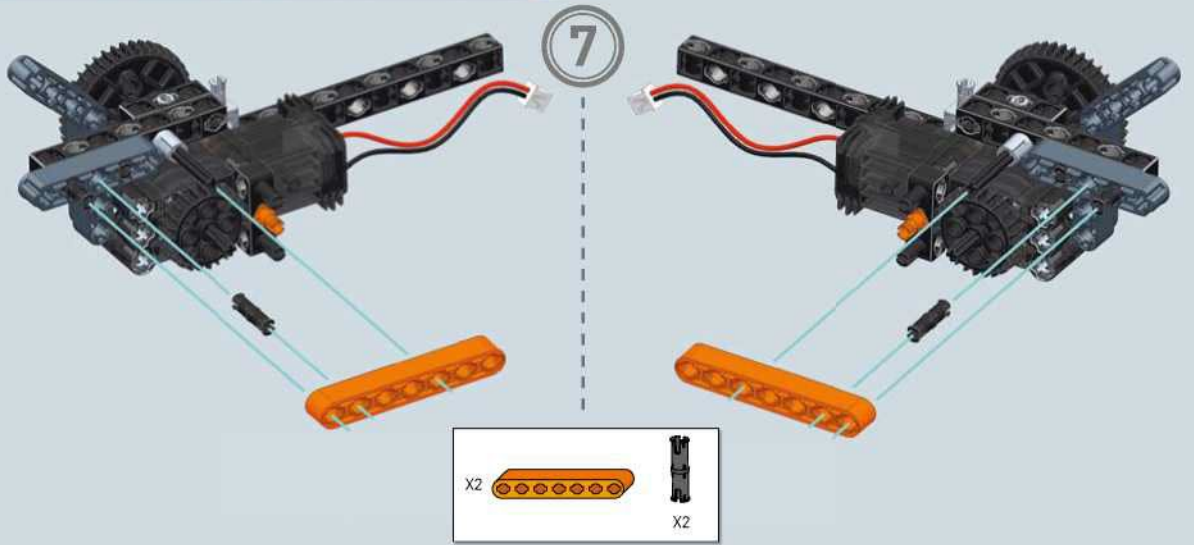

12

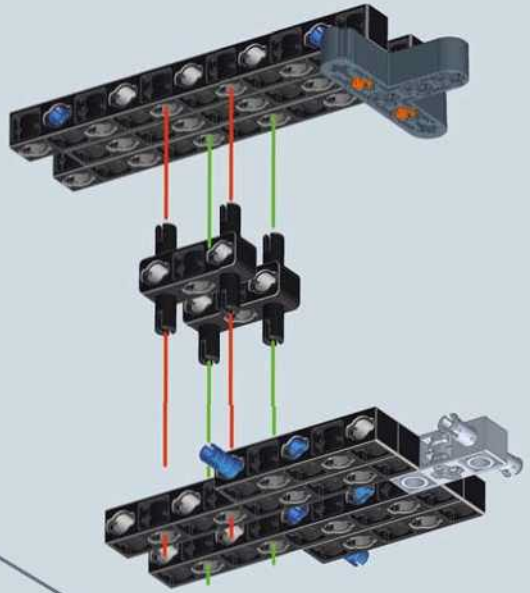
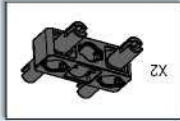

11

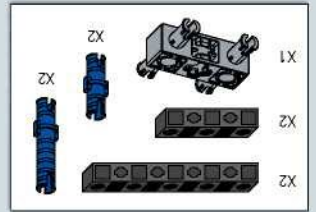
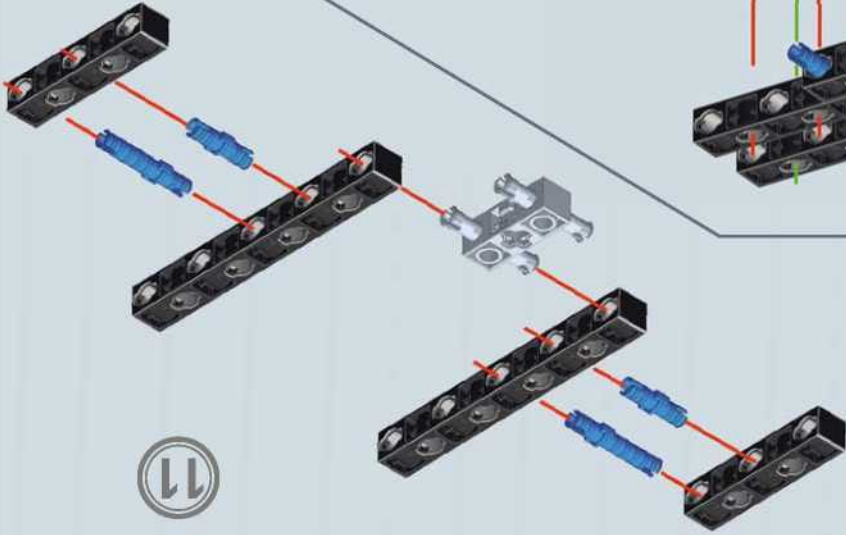

10

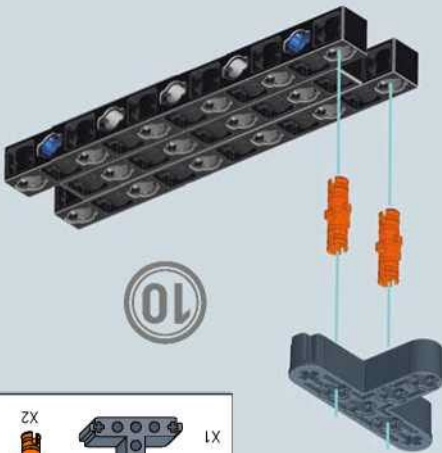
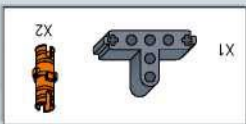

6

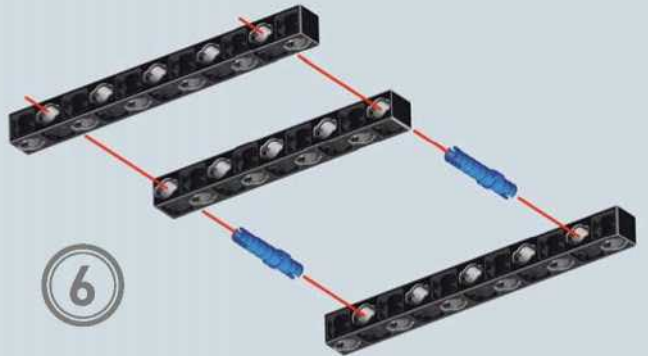
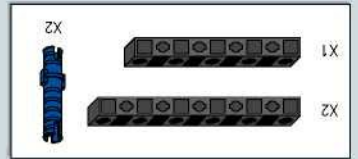

15

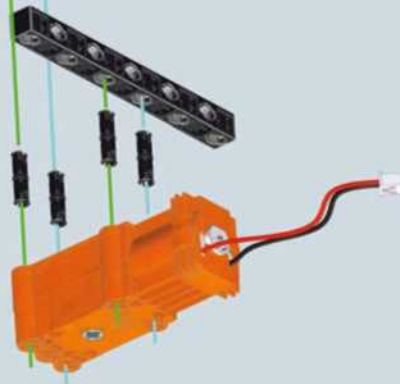
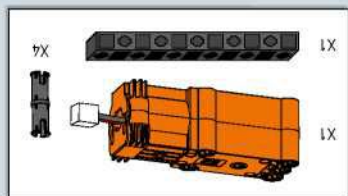
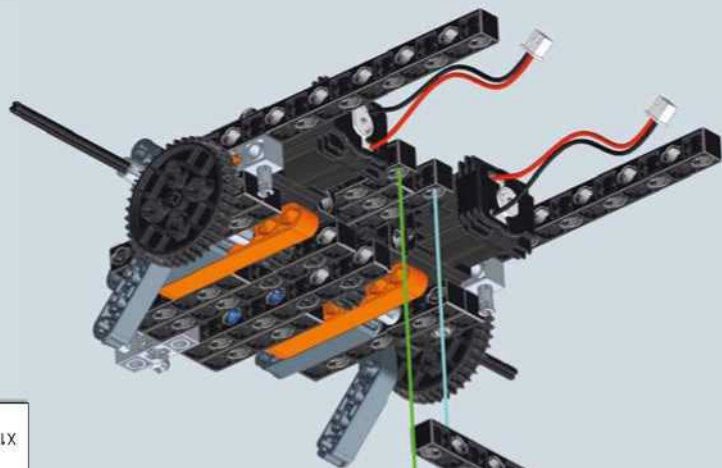

14

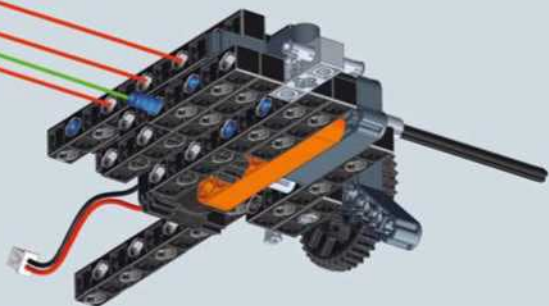
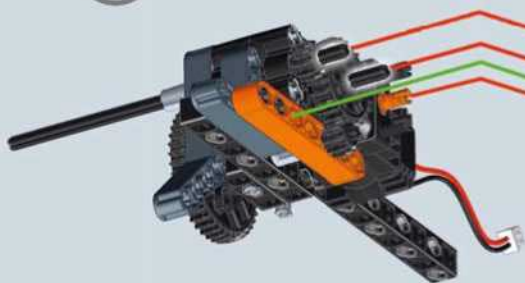

13

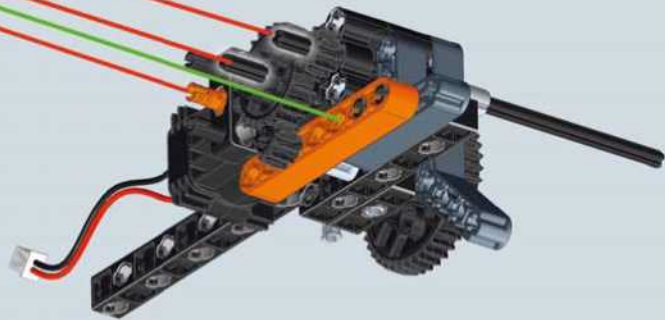
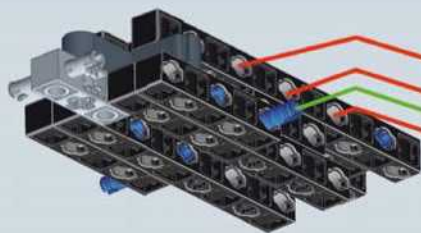

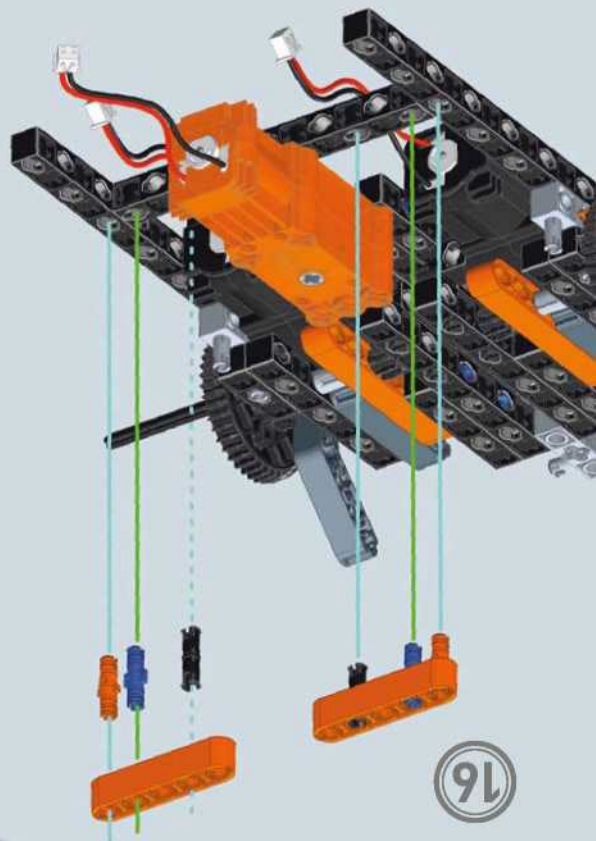
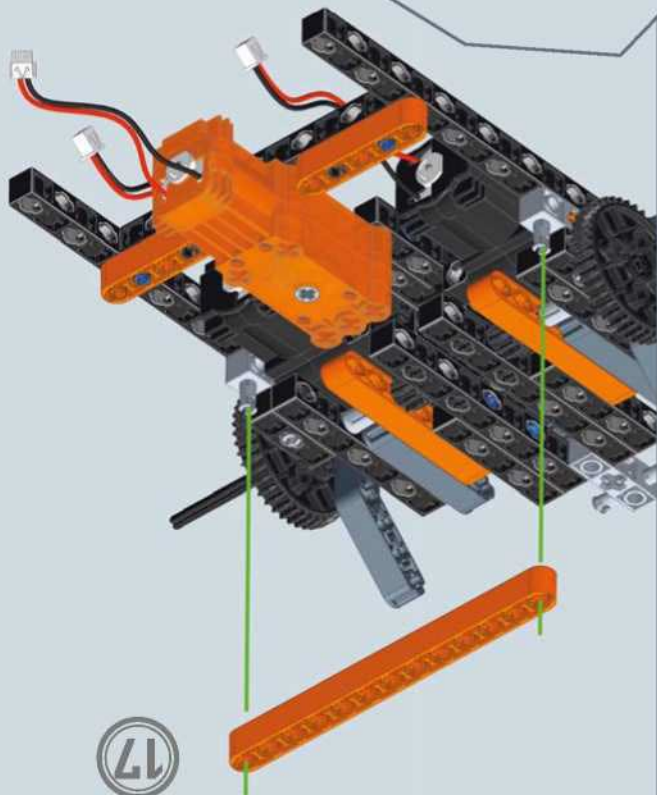
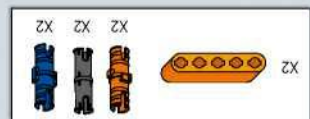

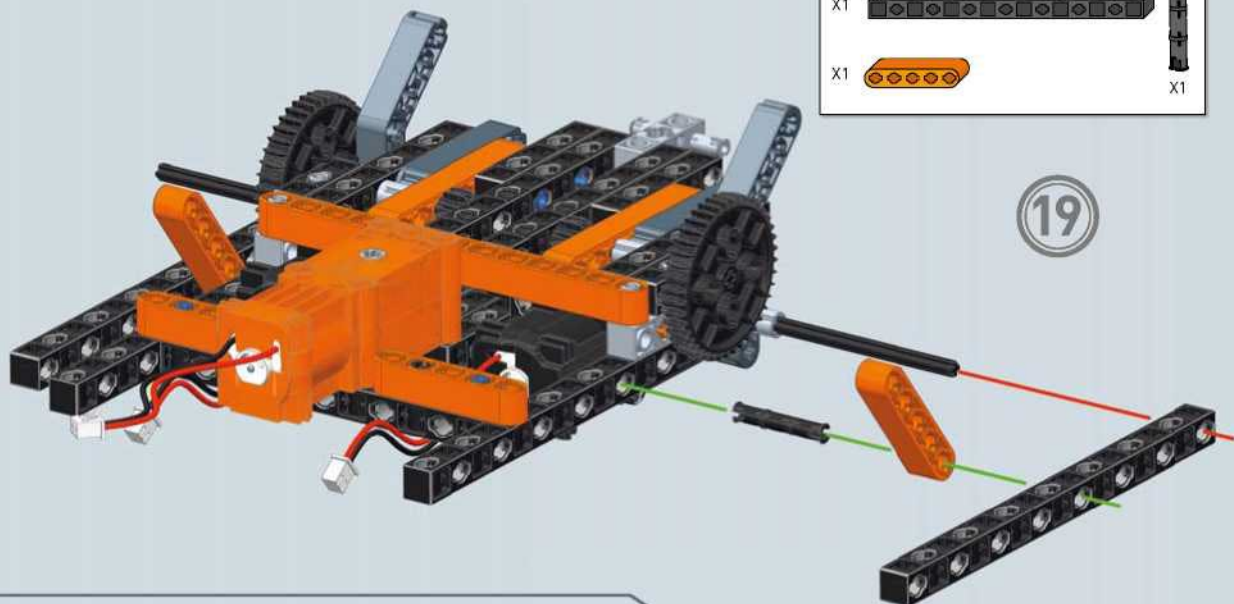

- X1
- X1
- X1

19

- X2
- X2
- X2
- X2

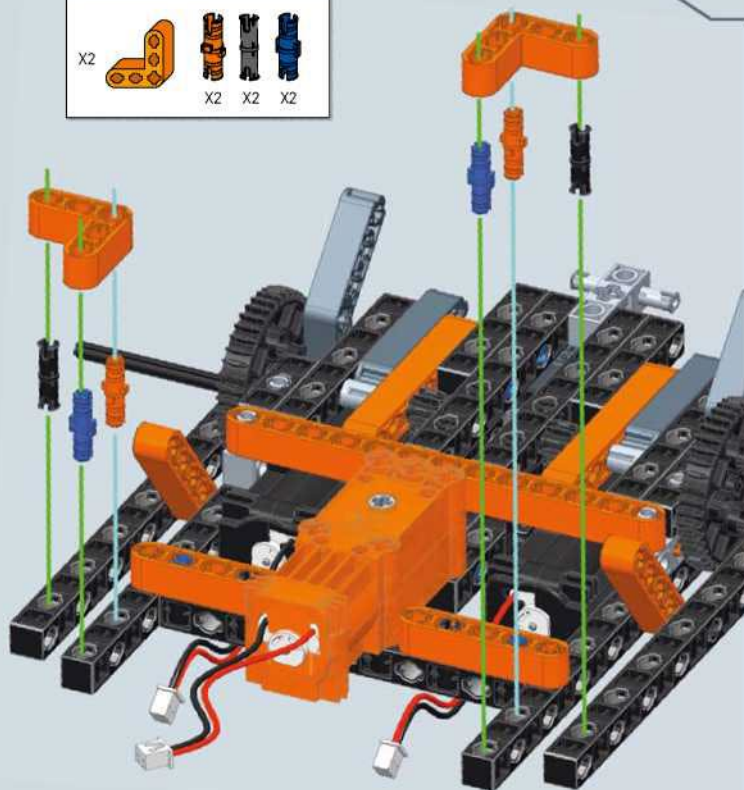

20

21



X2



- X2
- X2
- X4



6

1:1

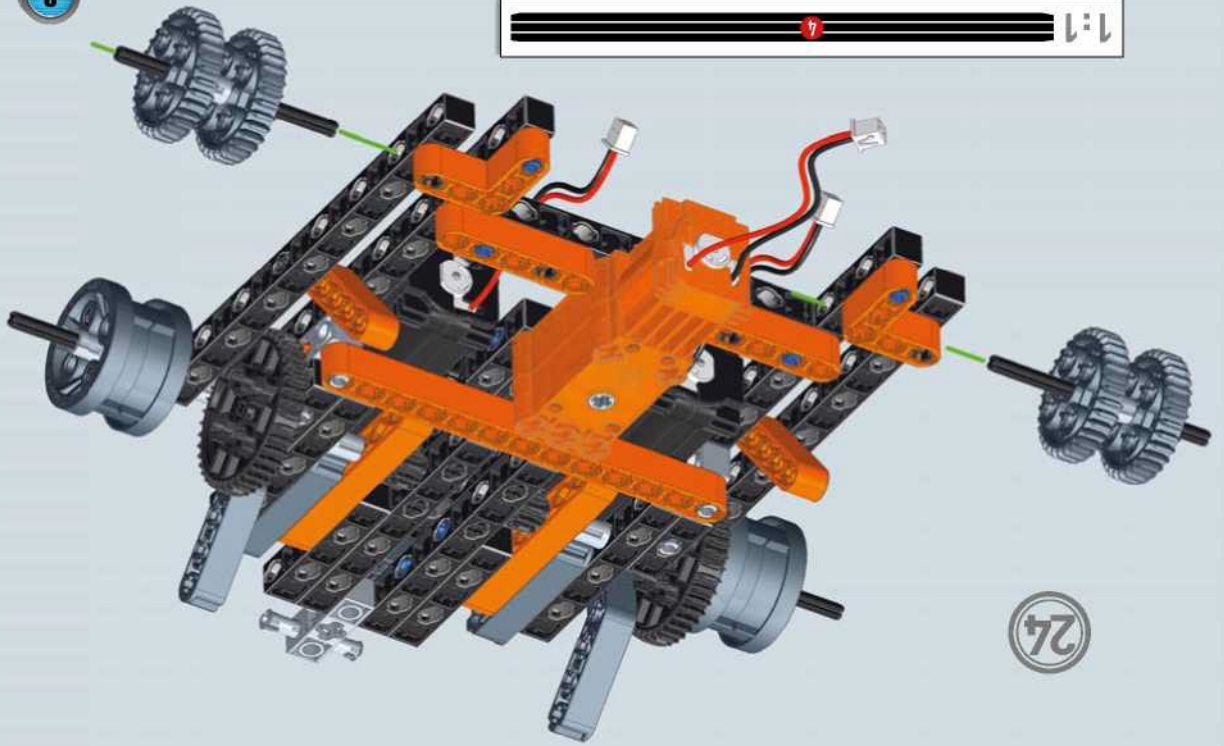

24



X2

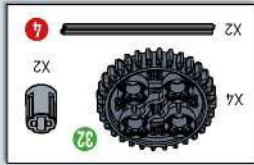

23

32

7

32

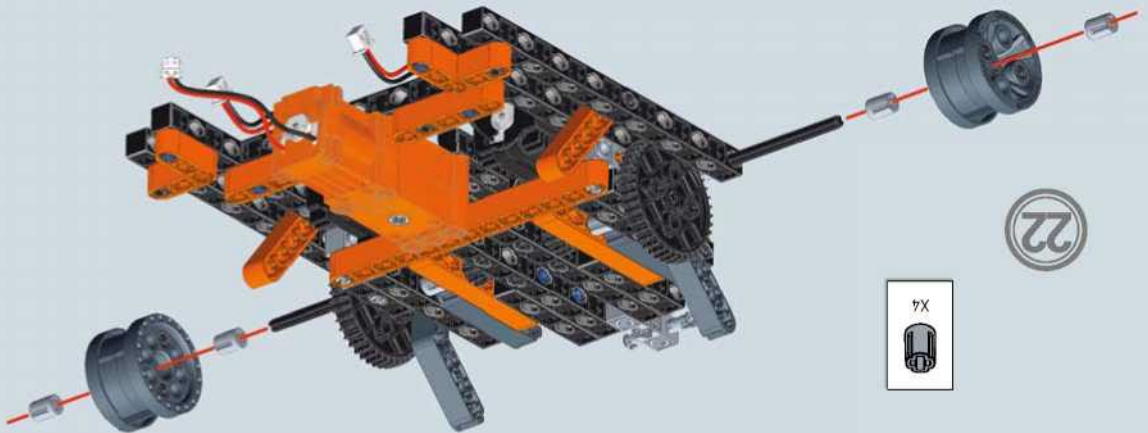

22



X4

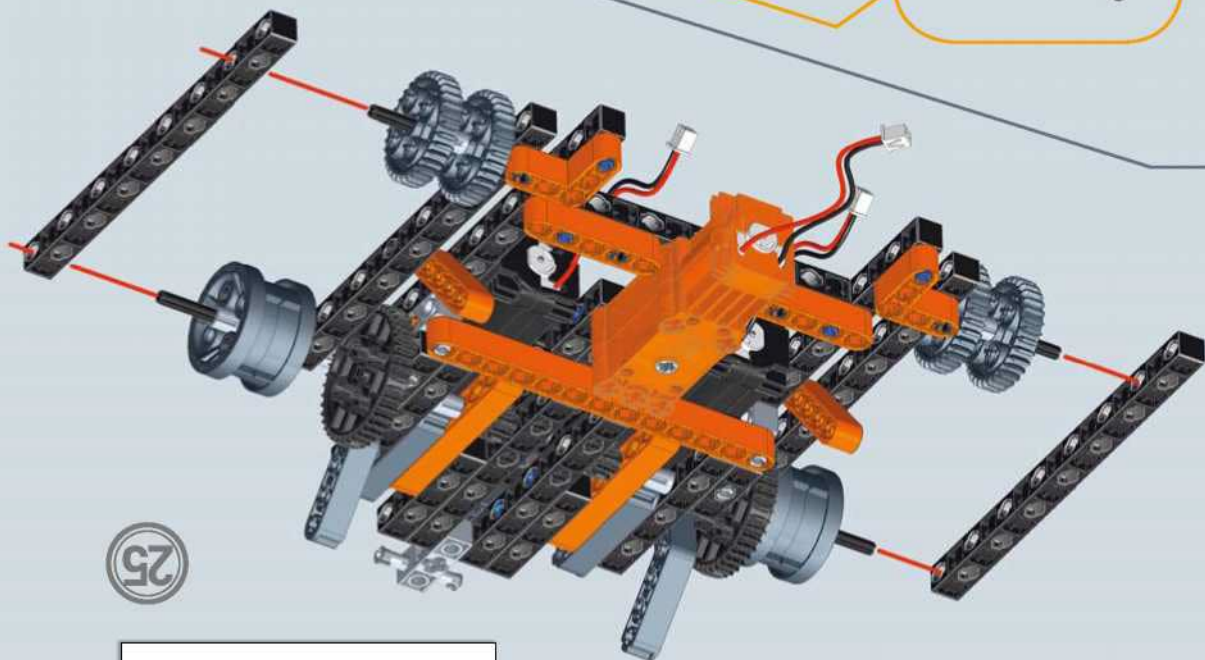
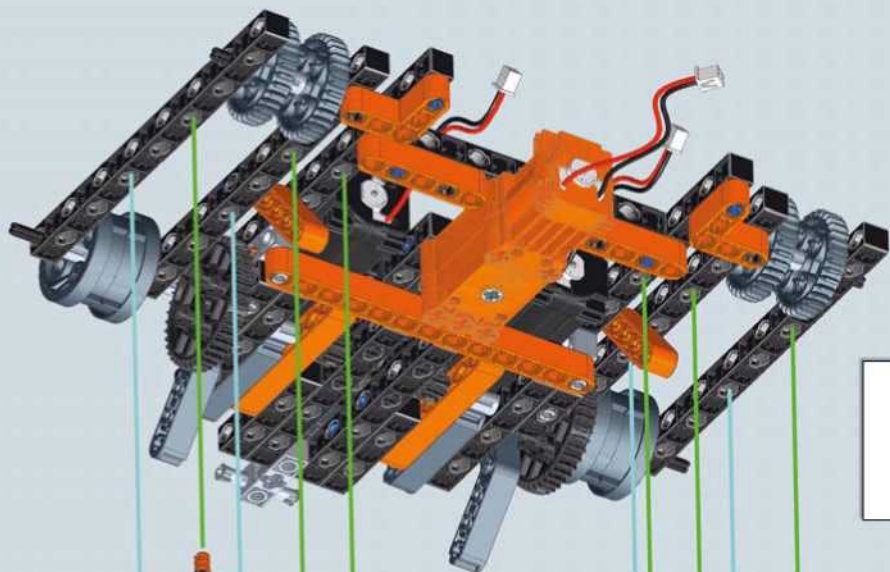

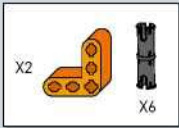

27

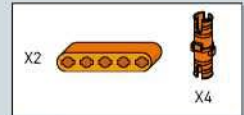
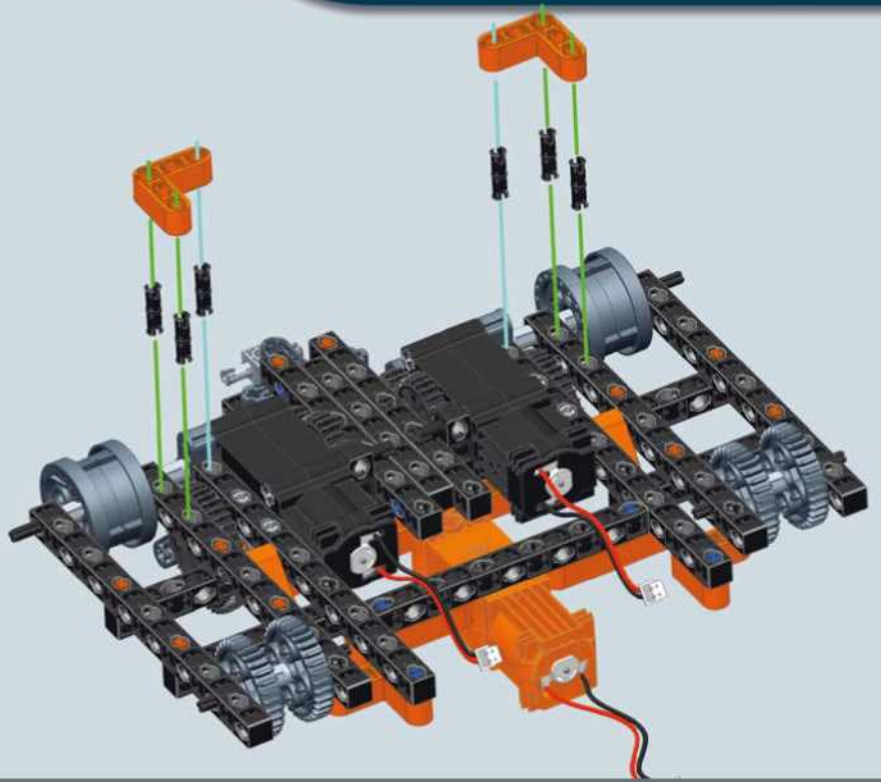

28

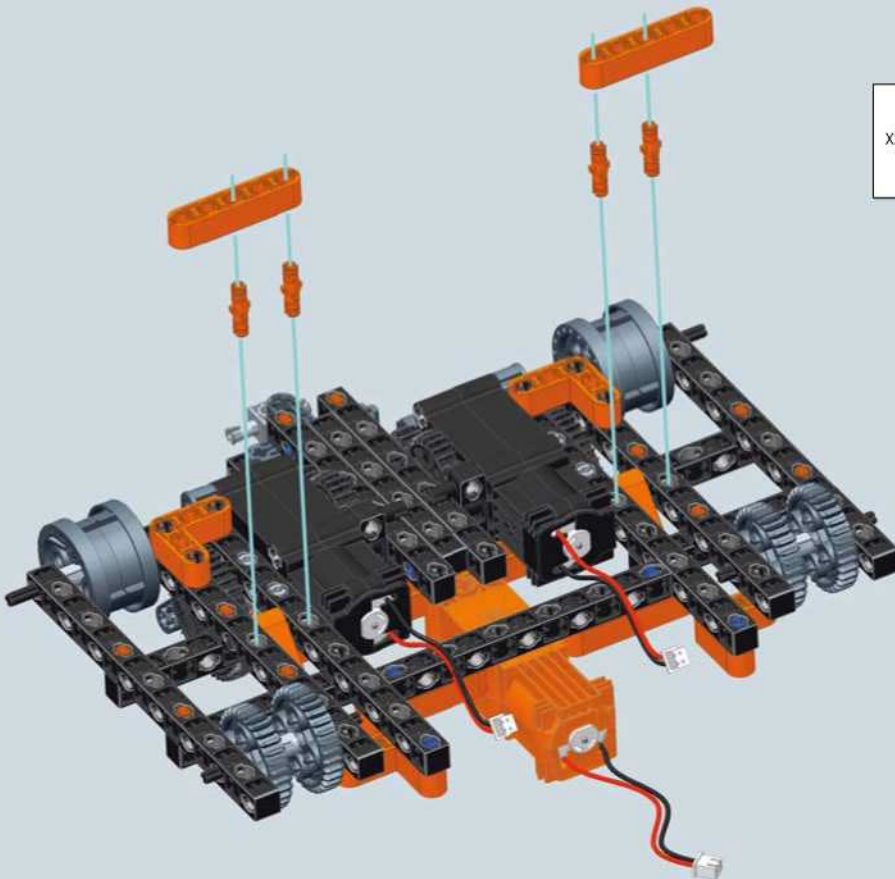



31

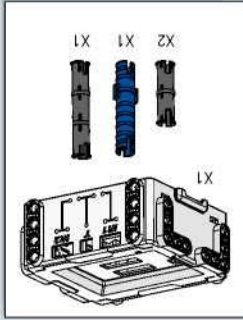

32



30

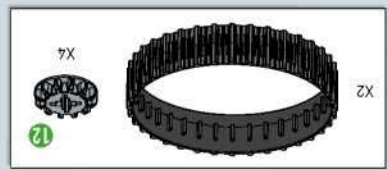
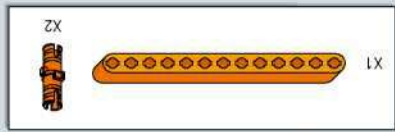
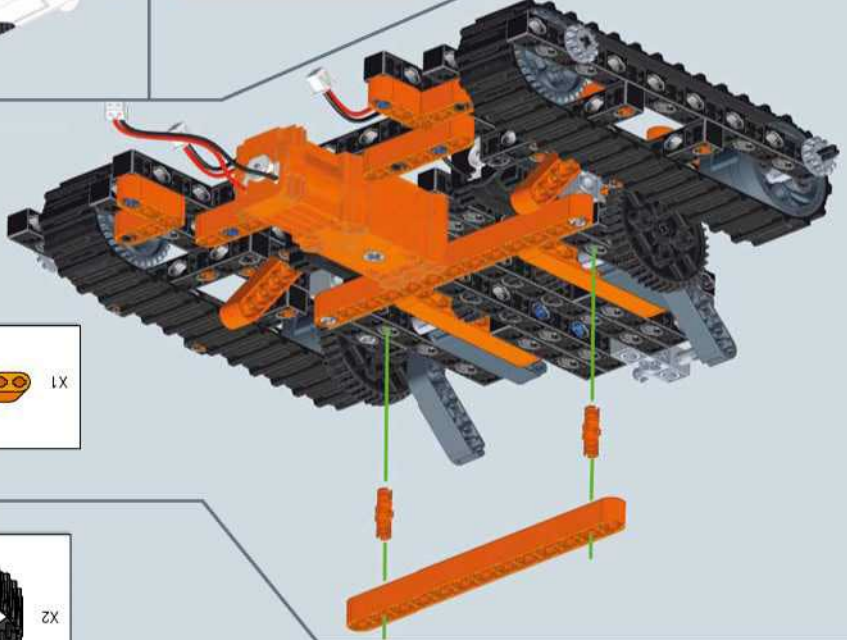

12

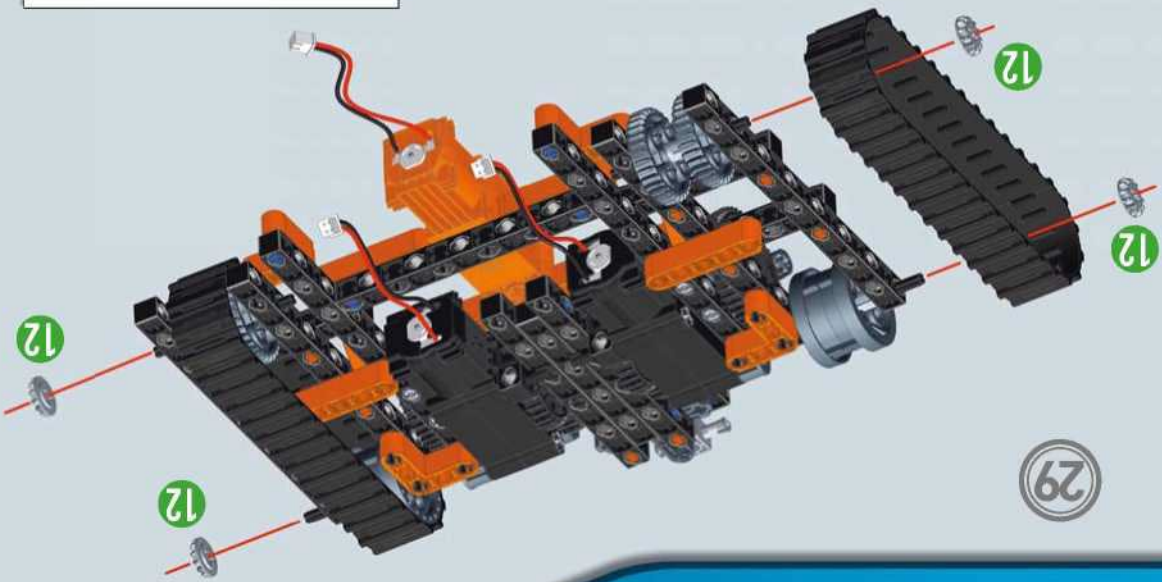

29



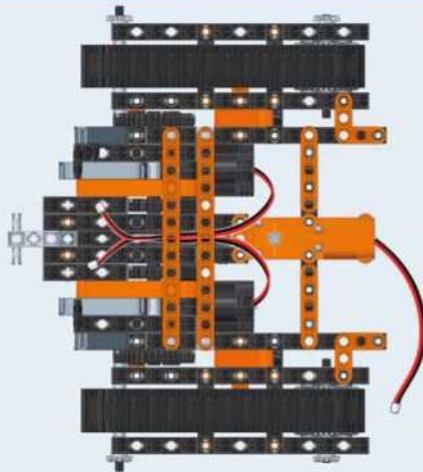

### VEDENÍ KABELŮ

Před připojením k modulu protáhněte vodiče obou černých motorů pod oranžovými tyčemi s 13 otvory, jak je znázorněno na obrázku.

### PŘIPOJENÍ MOTORŮ PRO CENTRÁLNÍ MODUL CENTRALNEGO

Umístěte model podle obrázku a připojte motor vlevo k portu M1 a motor vpravo k portu M2. Nakonec připojte oranžový motor k portu M3.

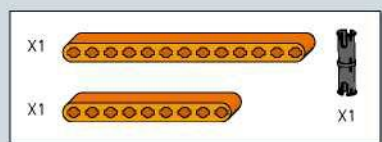
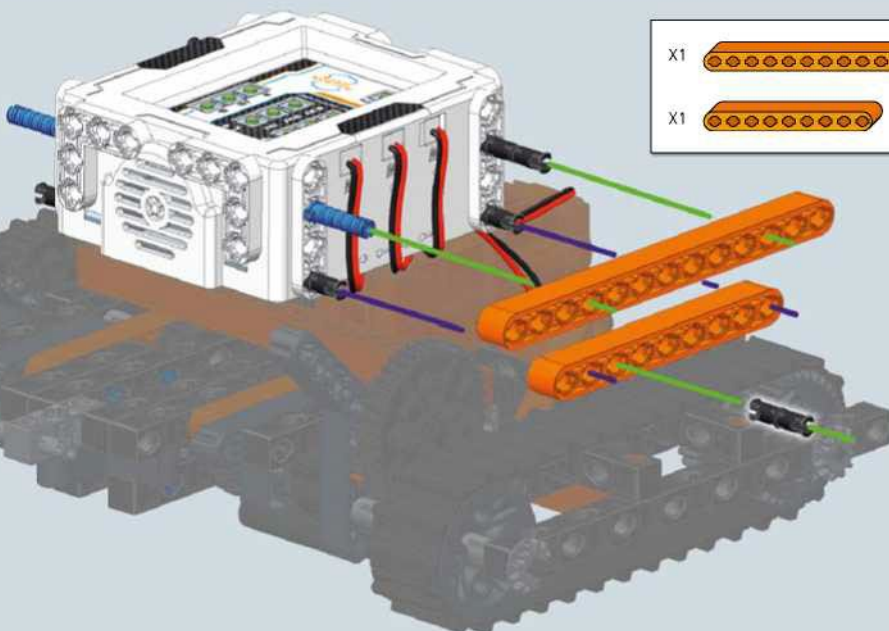
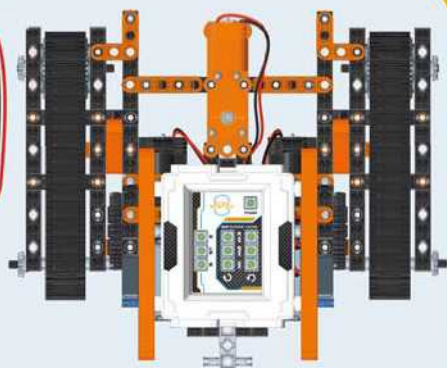
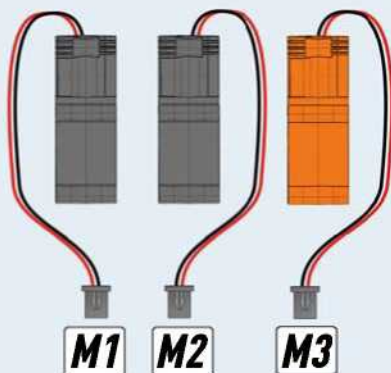

33

36

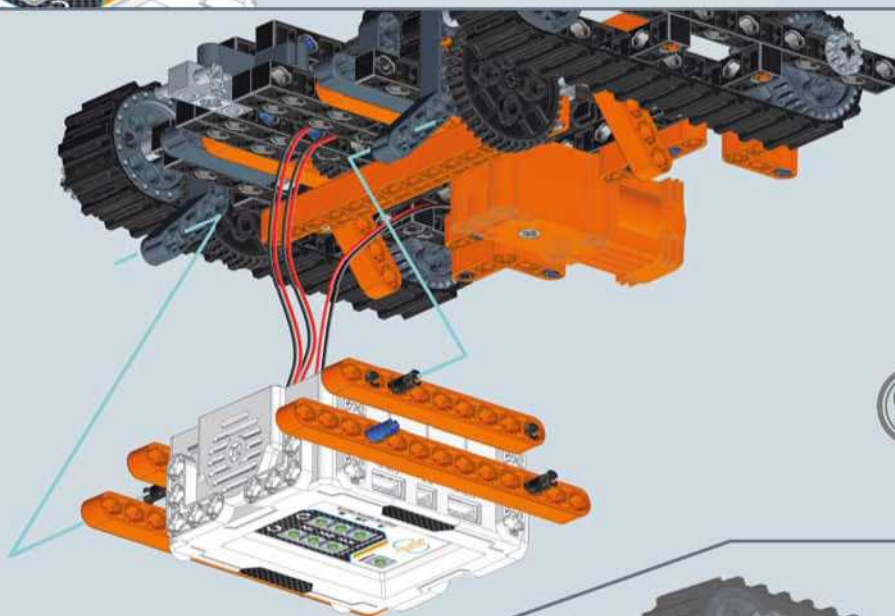
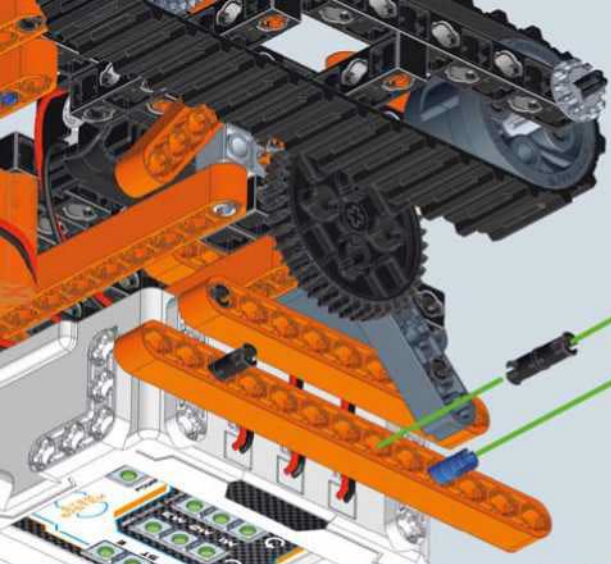
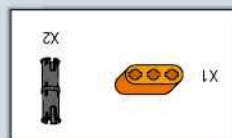

35

37

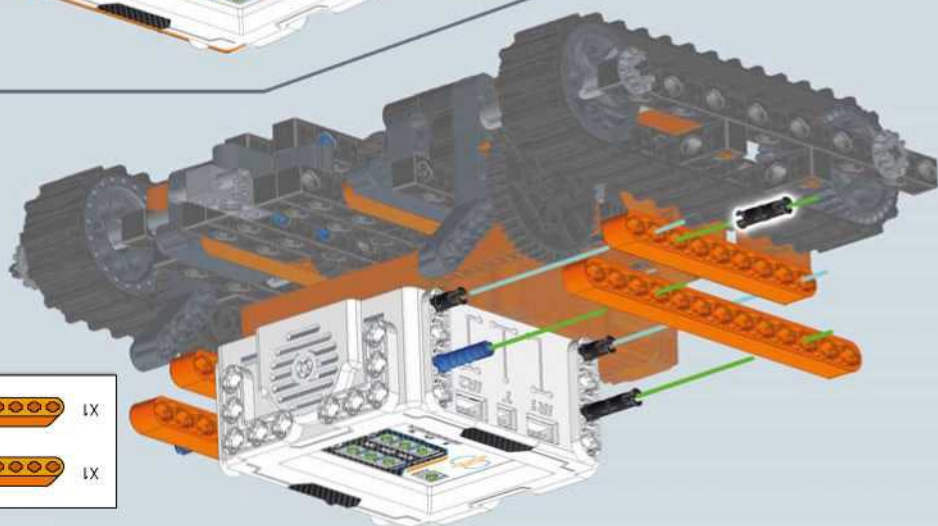
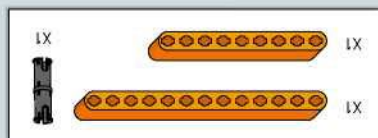

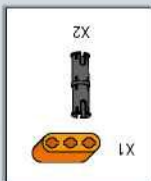
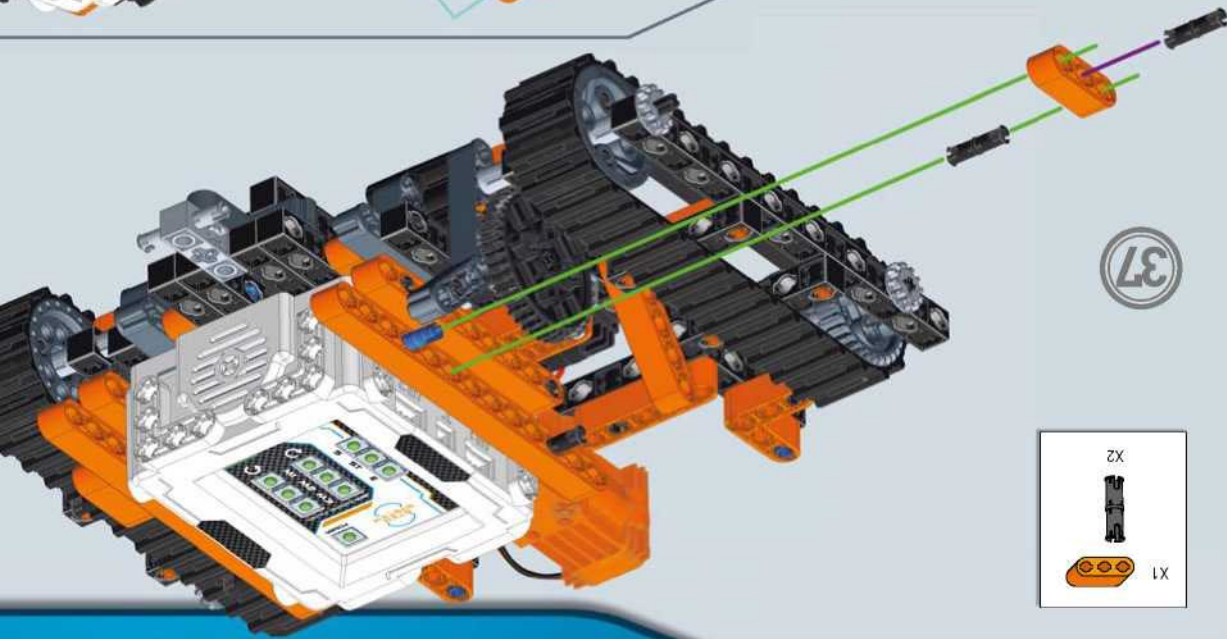
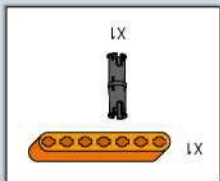
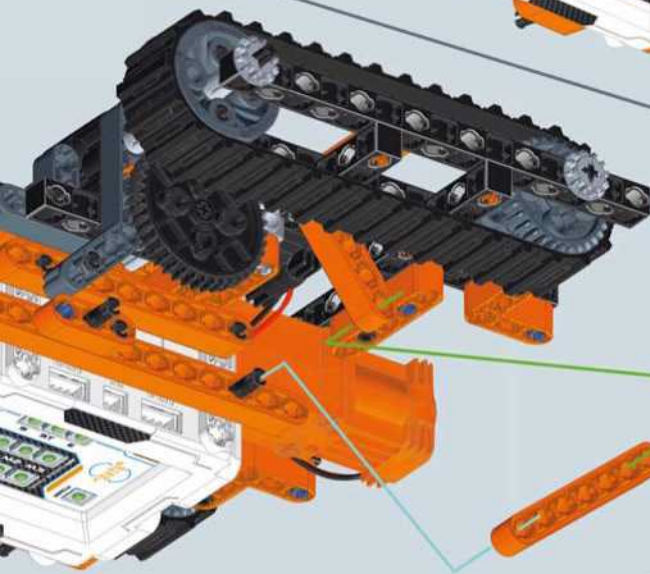
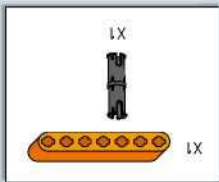
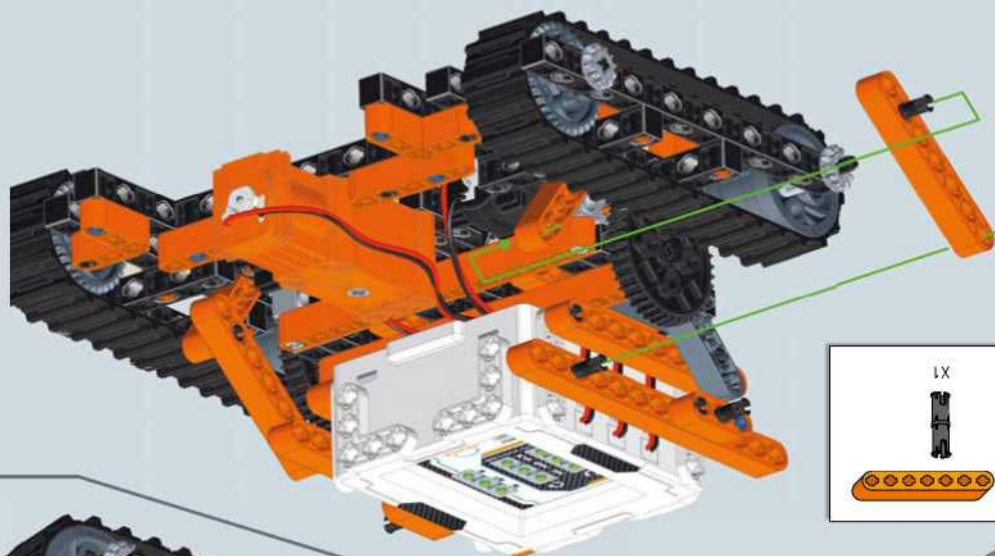

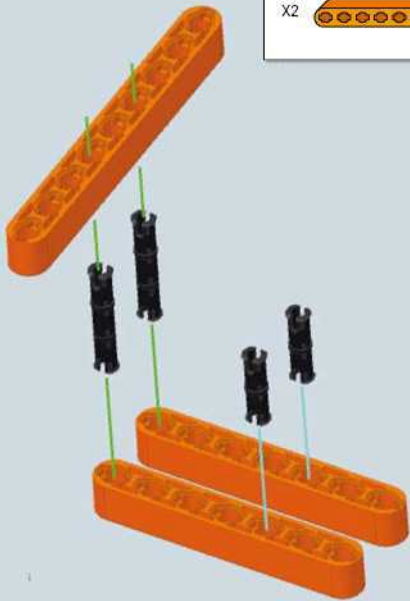
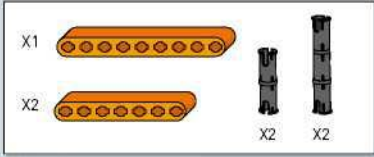

40

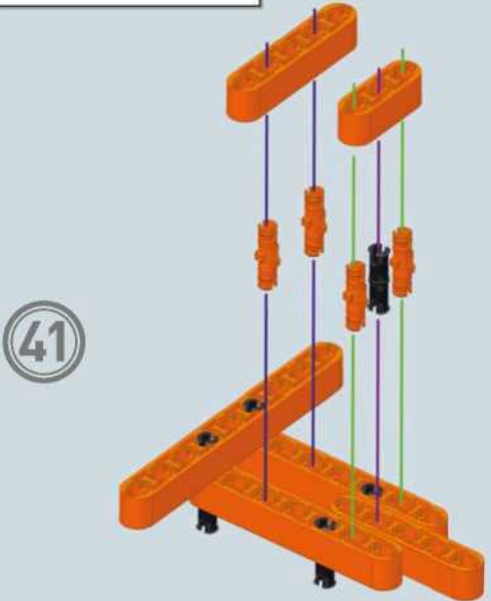
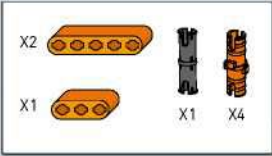

41

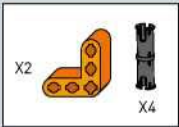

42

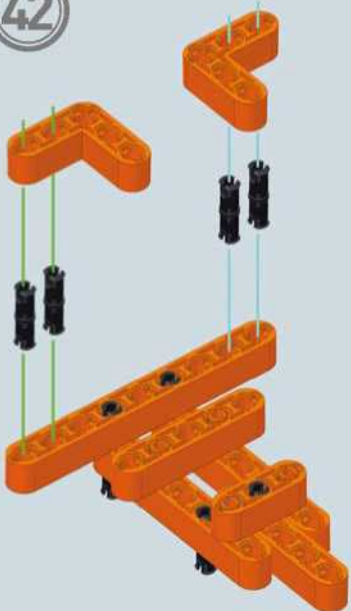

43

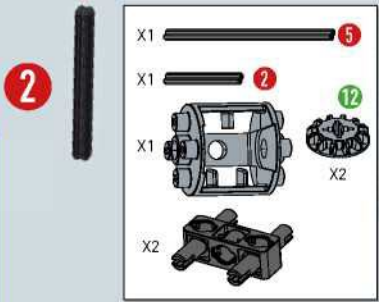
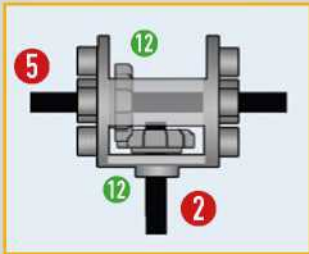
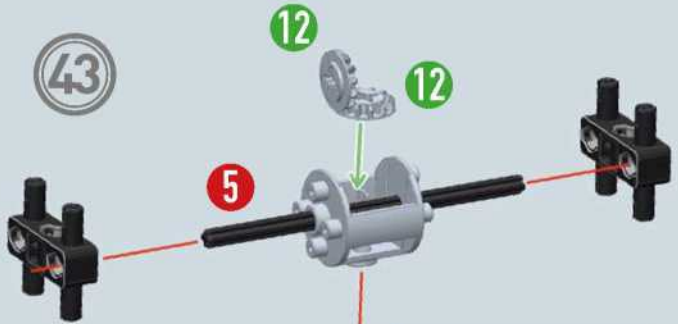



44

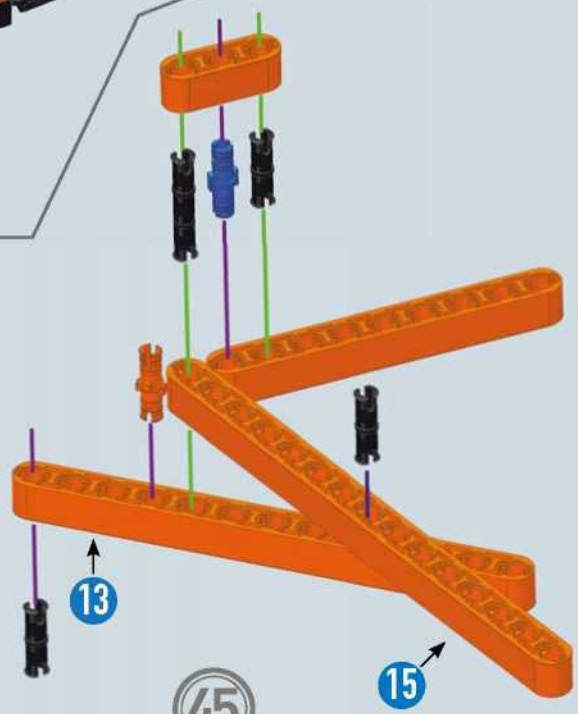
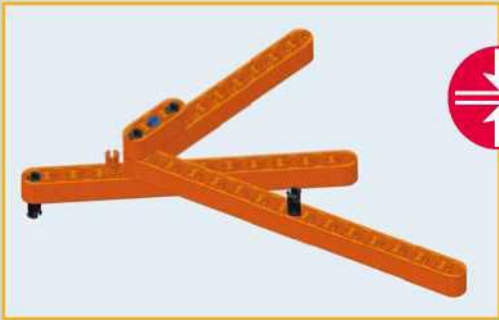
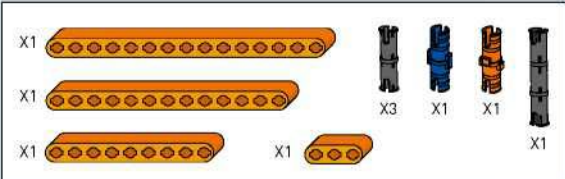
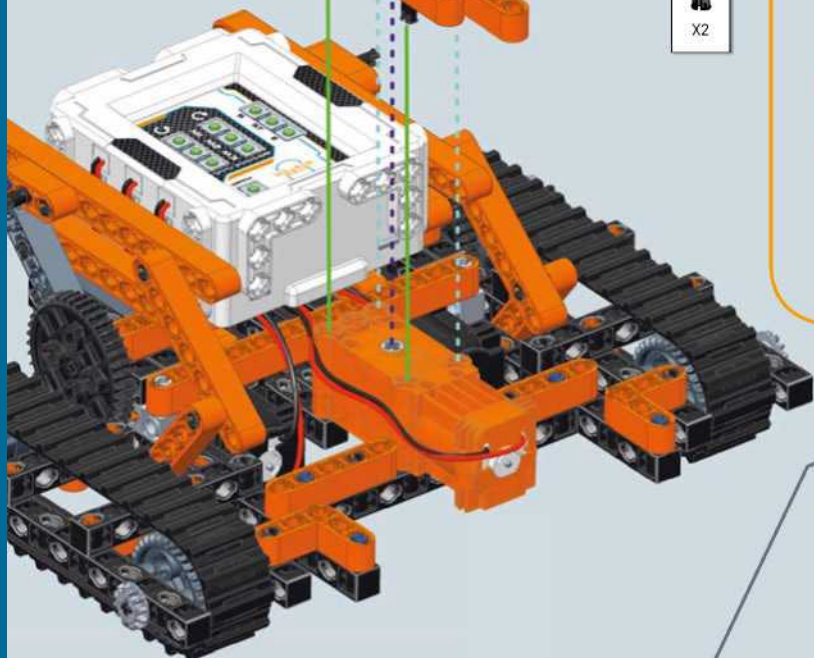
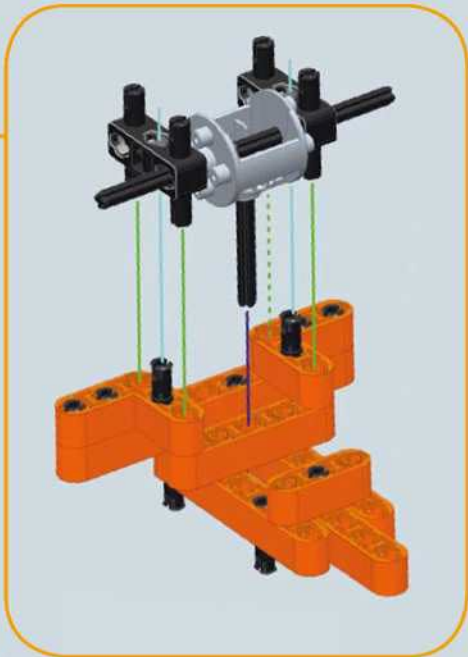
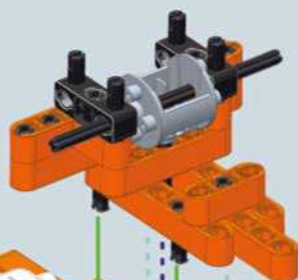



87

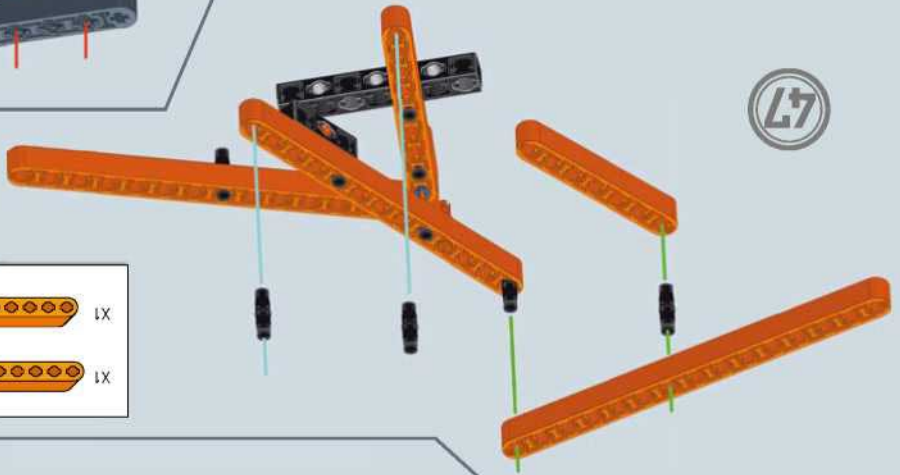
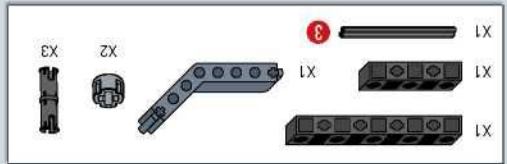

9

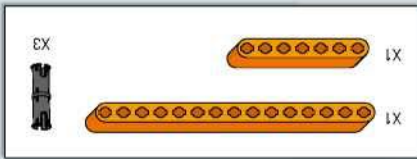

10

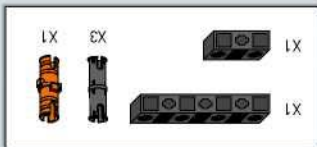

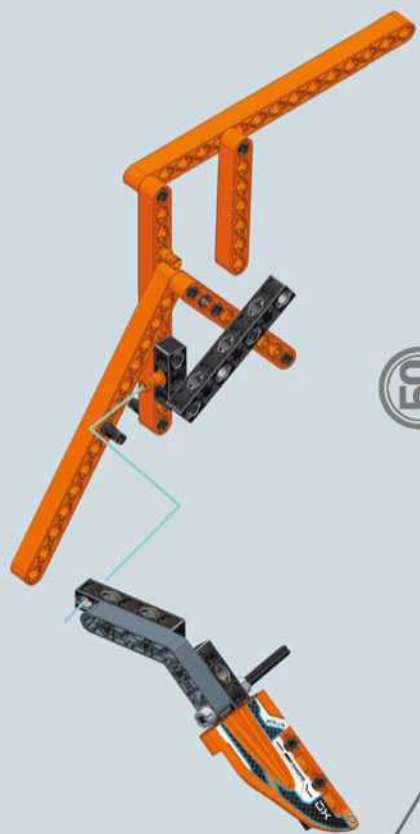

50

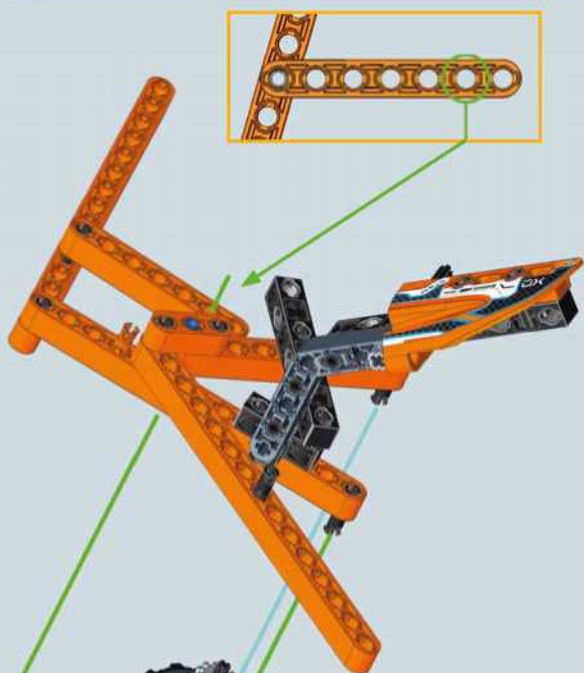

51

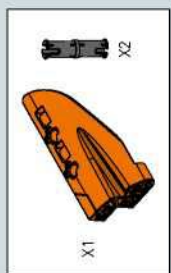

49

X2

X1

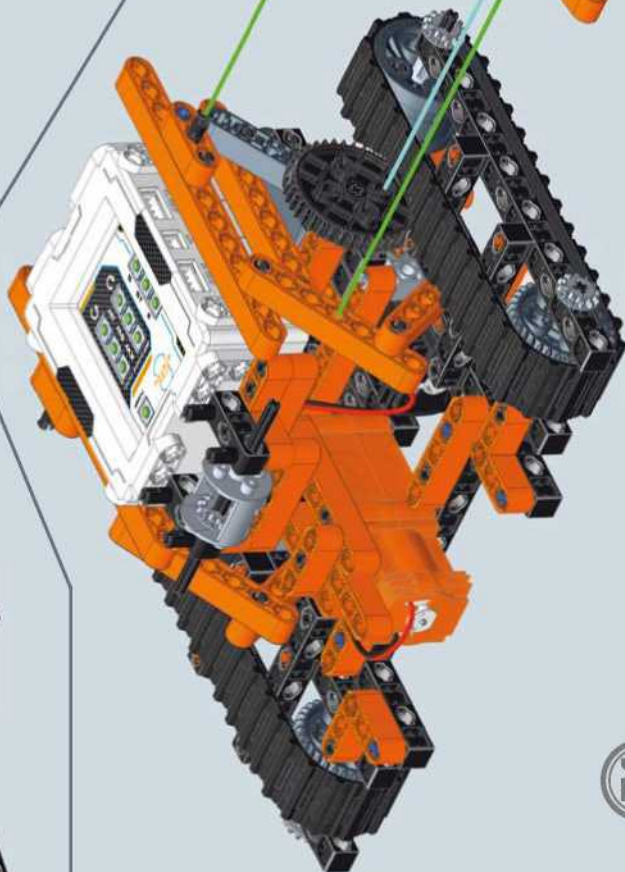
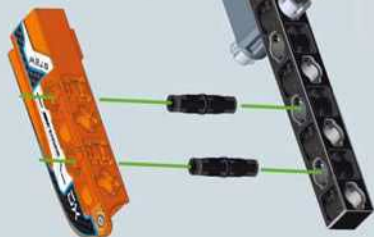

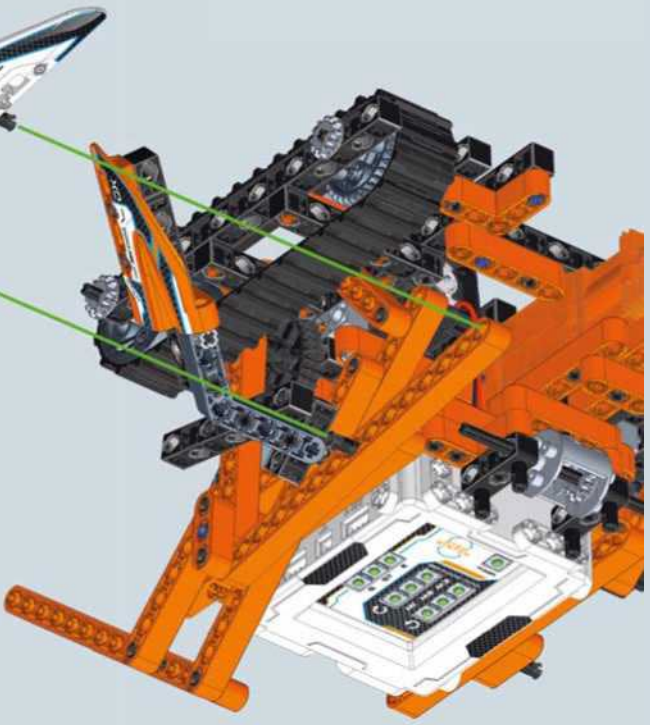
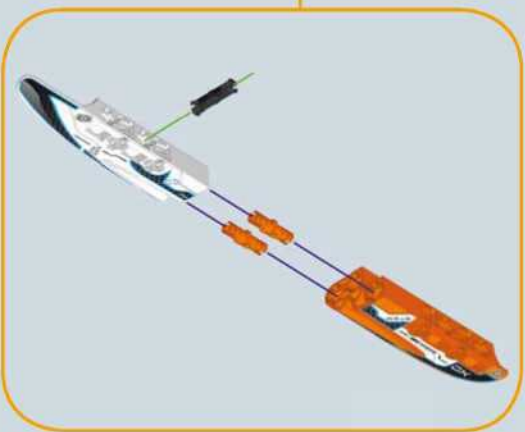
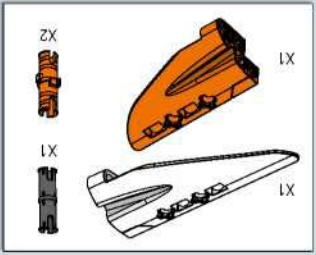
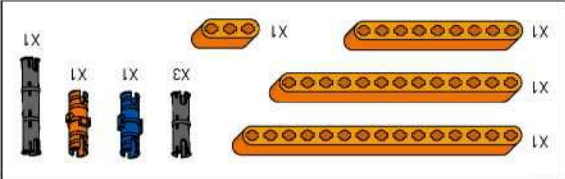
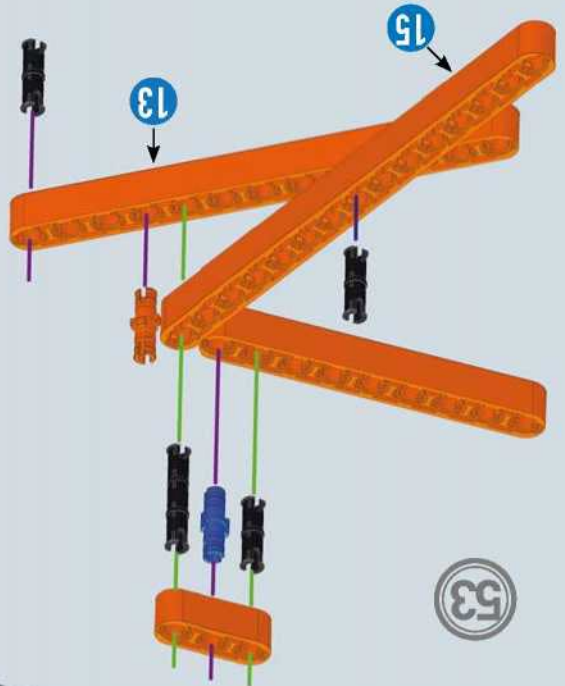

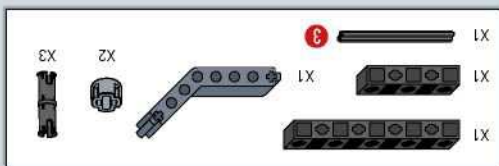

55

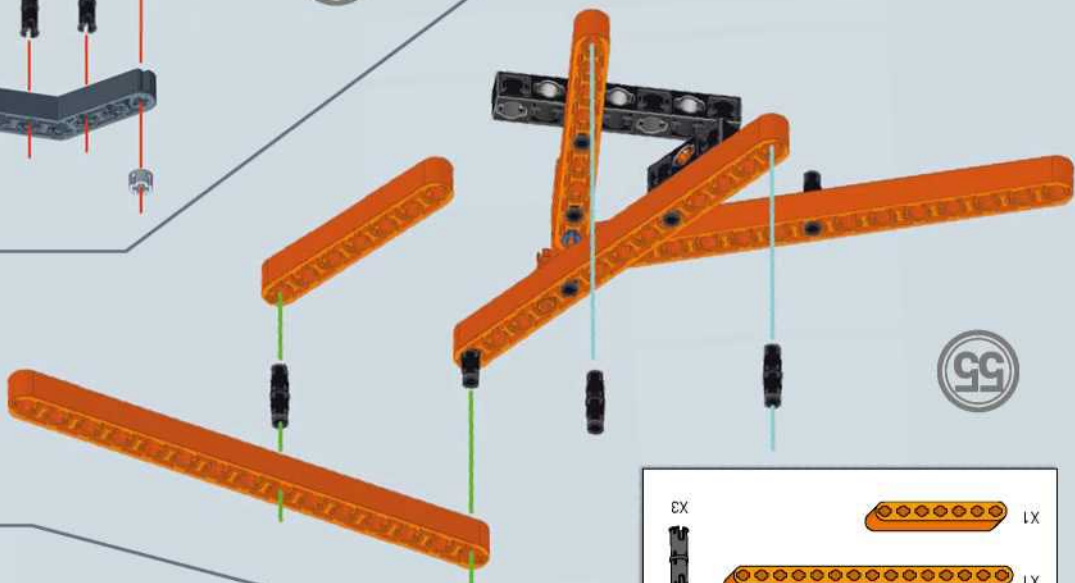

55

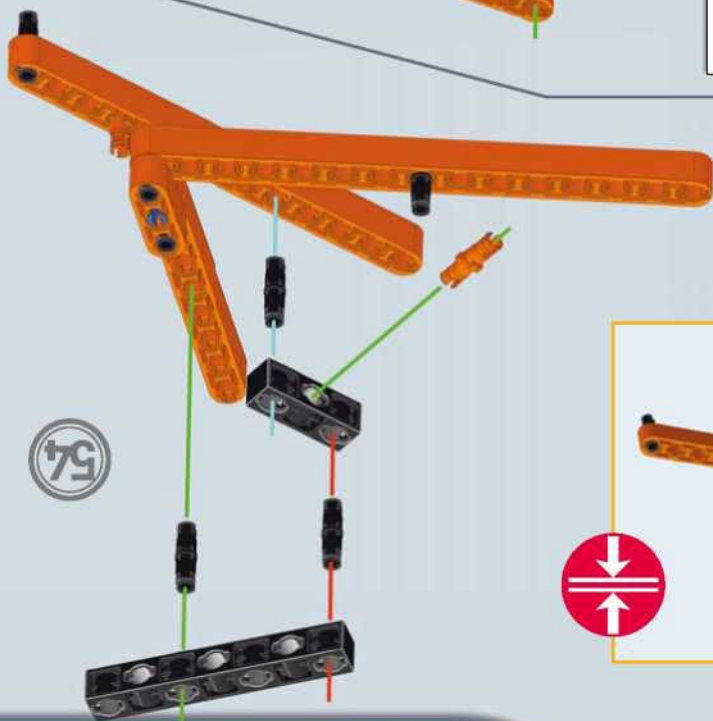
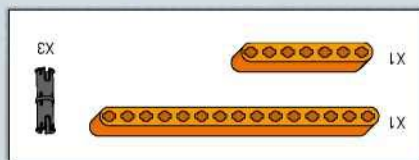

54

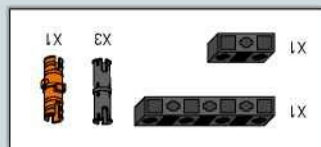

58

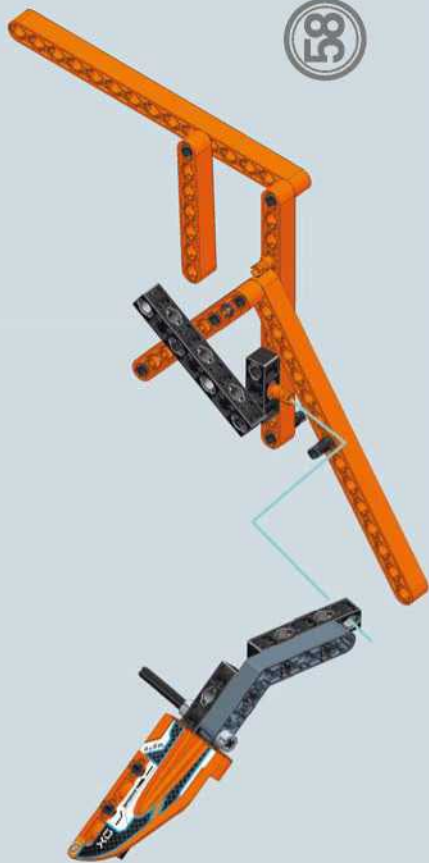

59



X2



X1

57



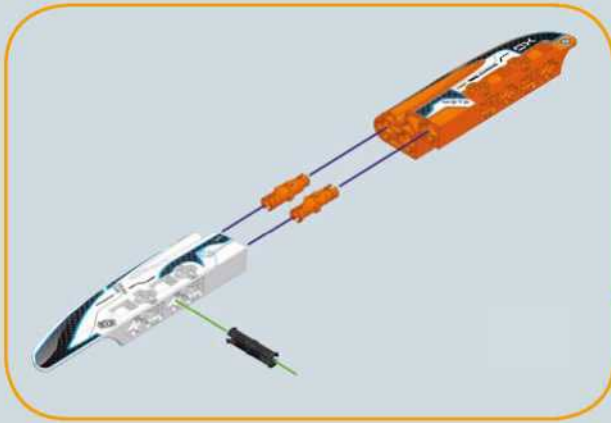
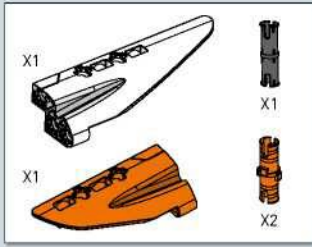

60

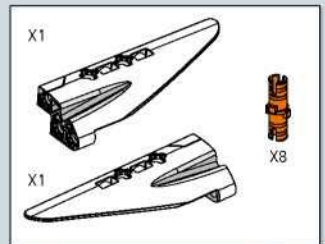
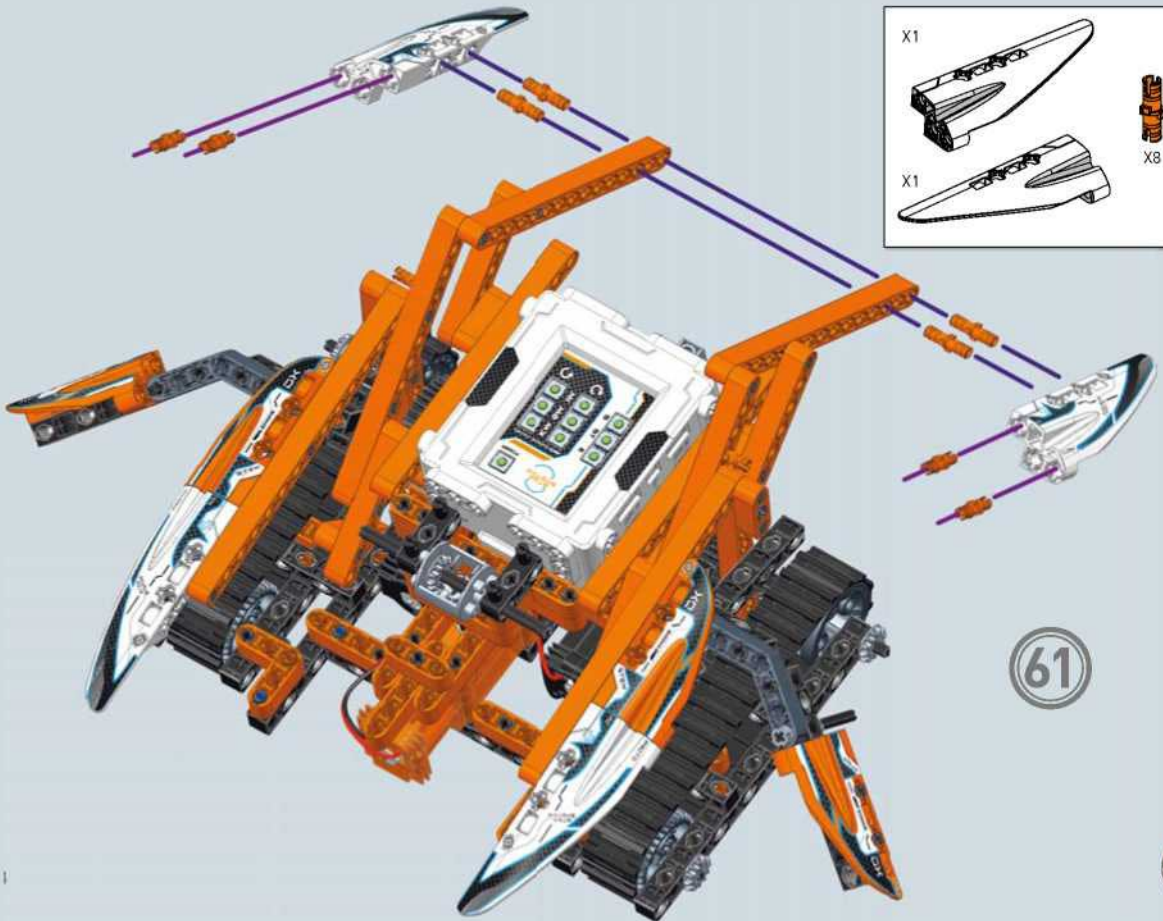

61

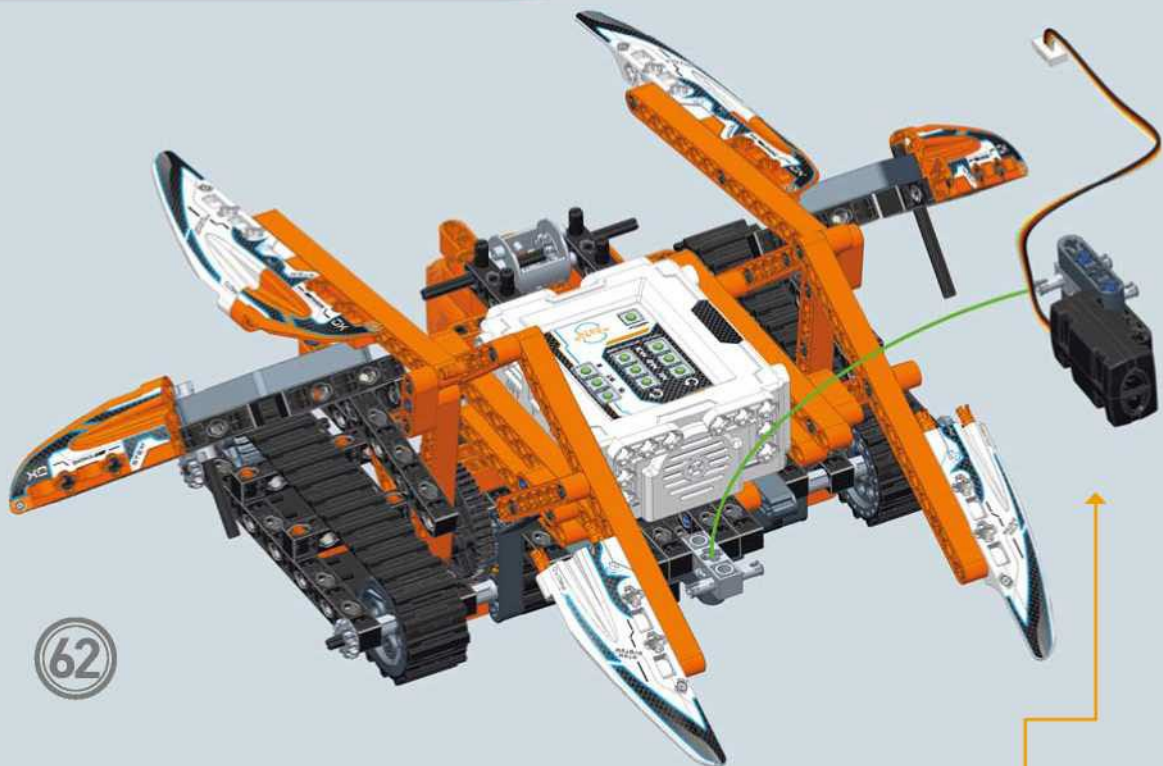

62

**PRIPOJENÍ SENZORU K  
CENTRÁLNÍ JEDNOTCE**

Připojte IR senzor k portu  
IR1 centrální jednotky.

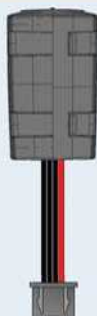

**IR1**

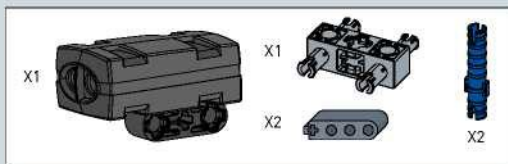
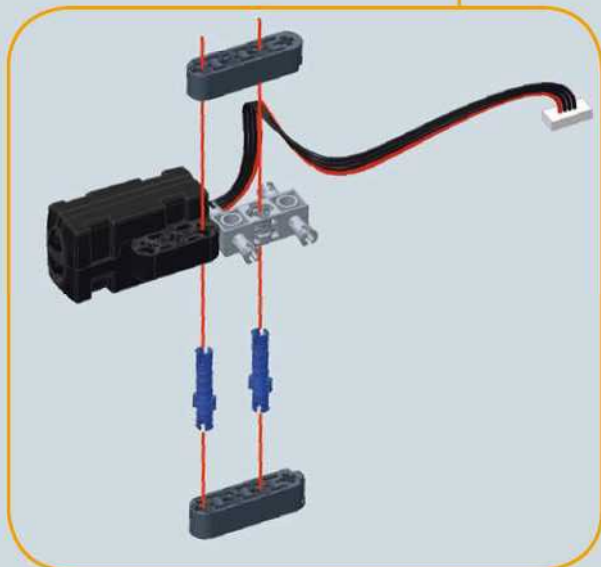



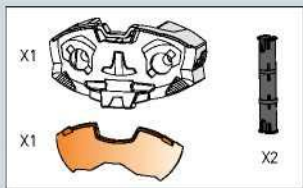

63

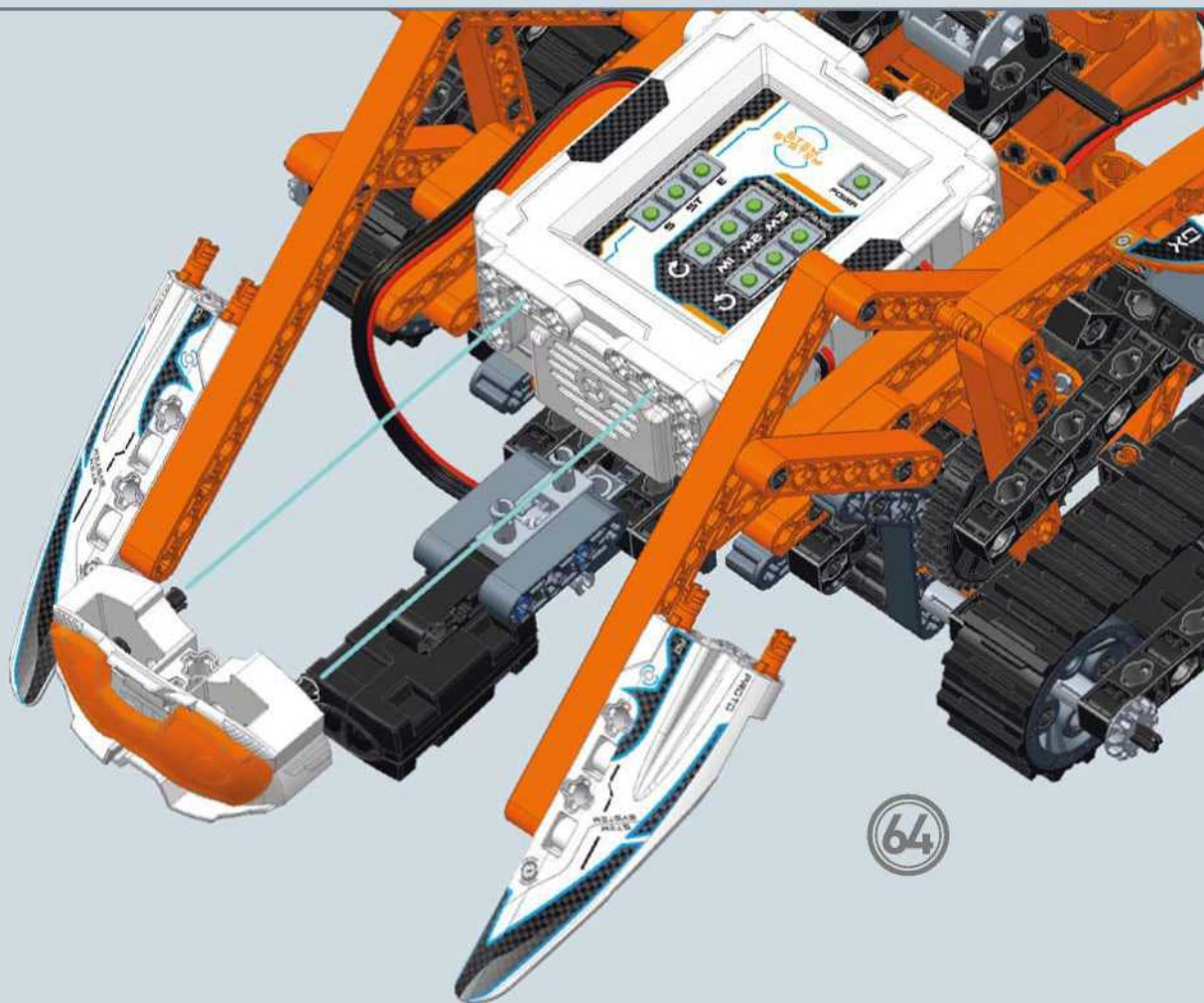
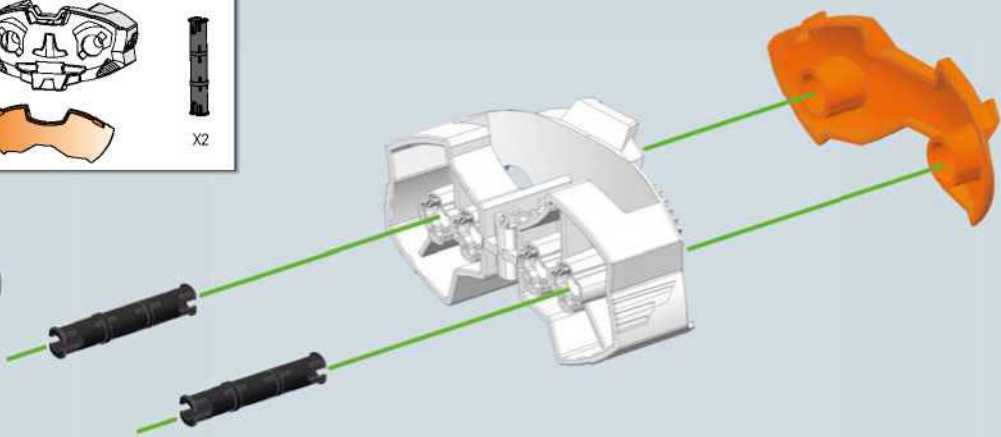

64

## DOKONČENÝ MODEL

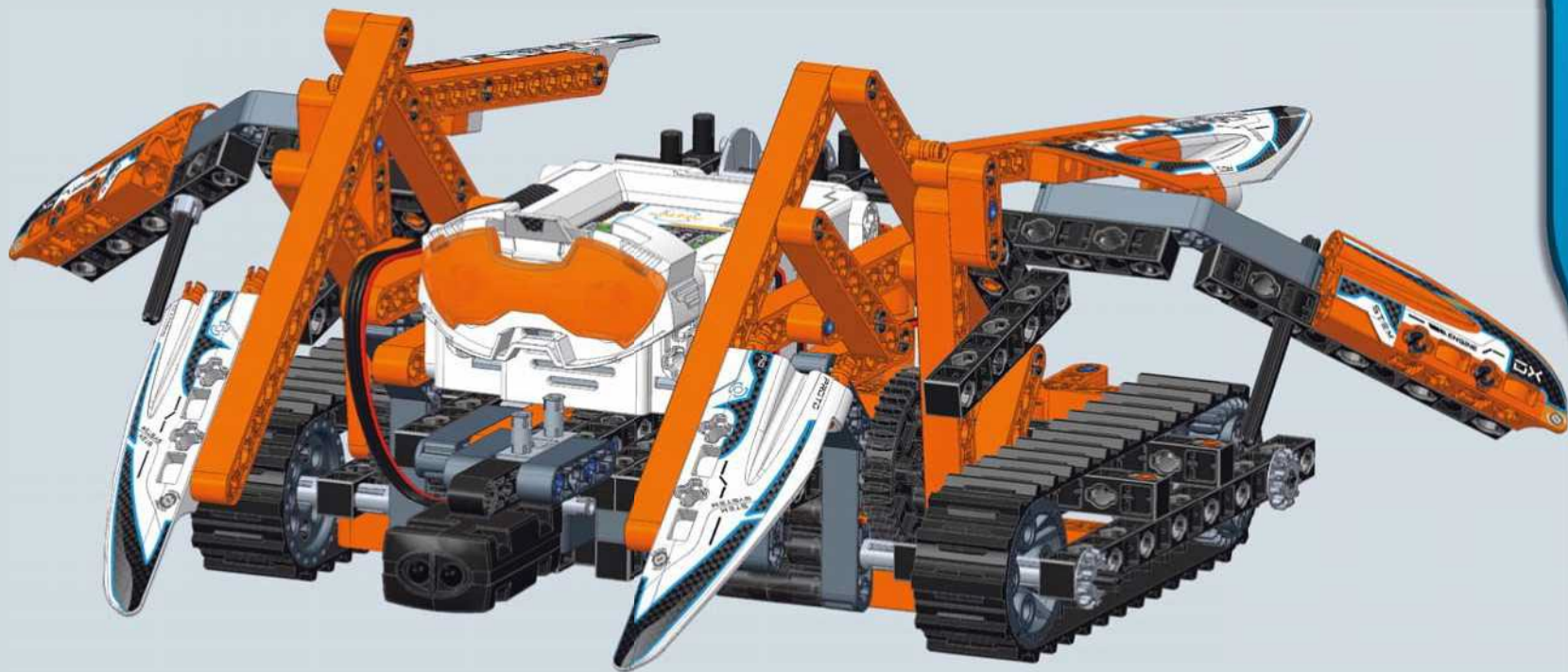

Sledujte oběť!

Montáž

S hotovým modelem robota kořisti postavte podle návodu robota dravce.

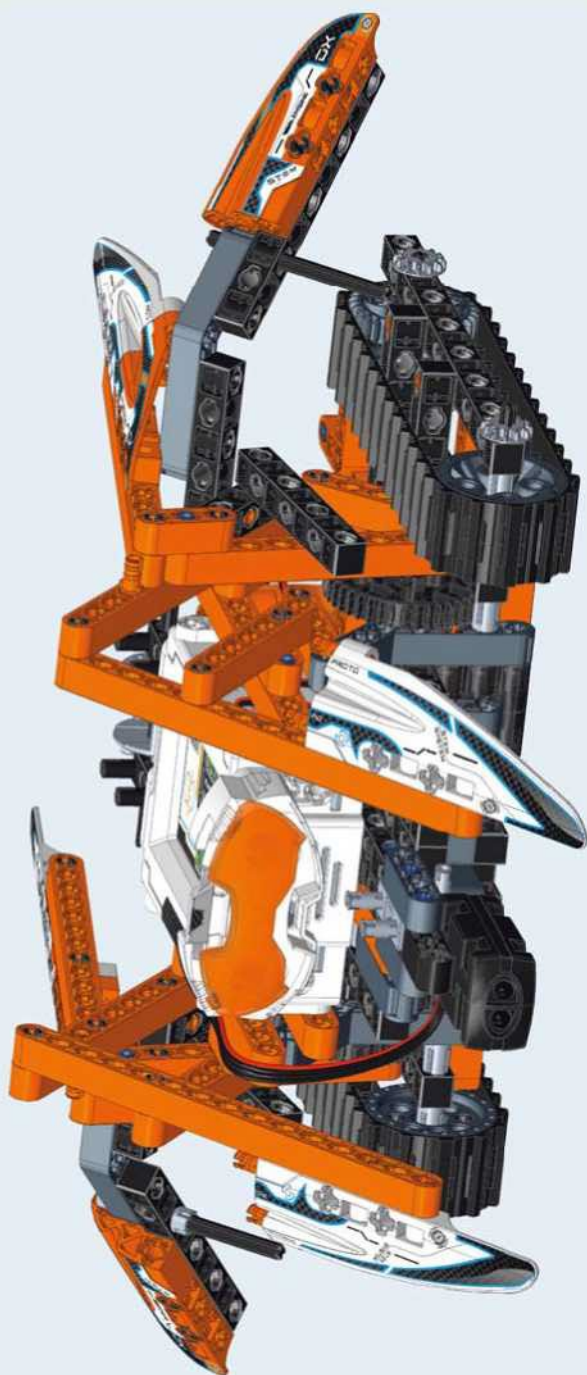

Sundejte si masku

1

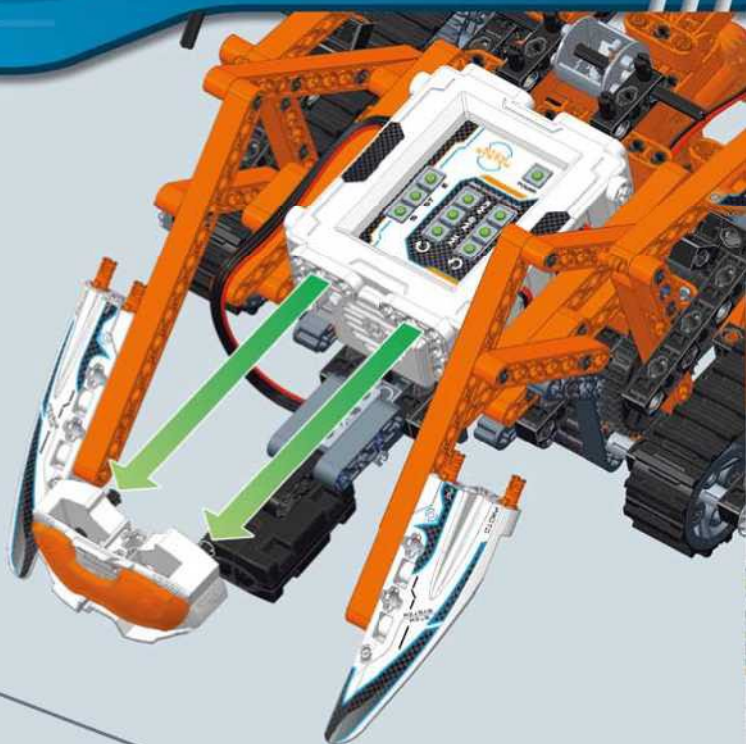

2



Vyjměte celý blok  
snímačů

3

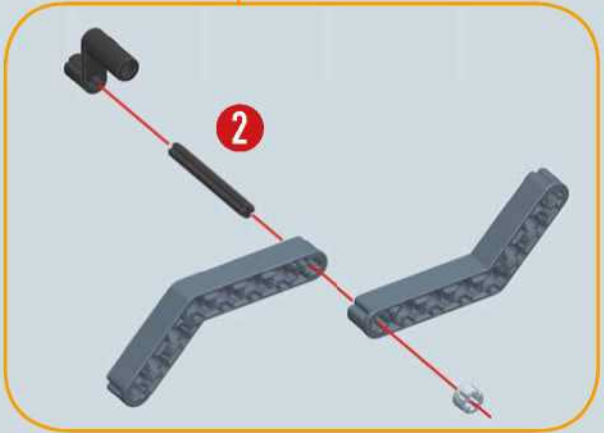
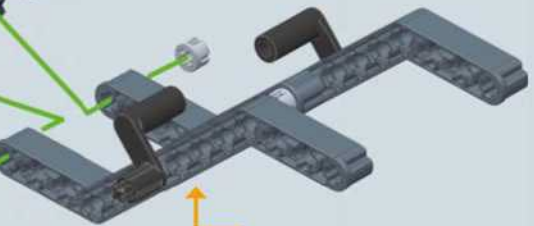
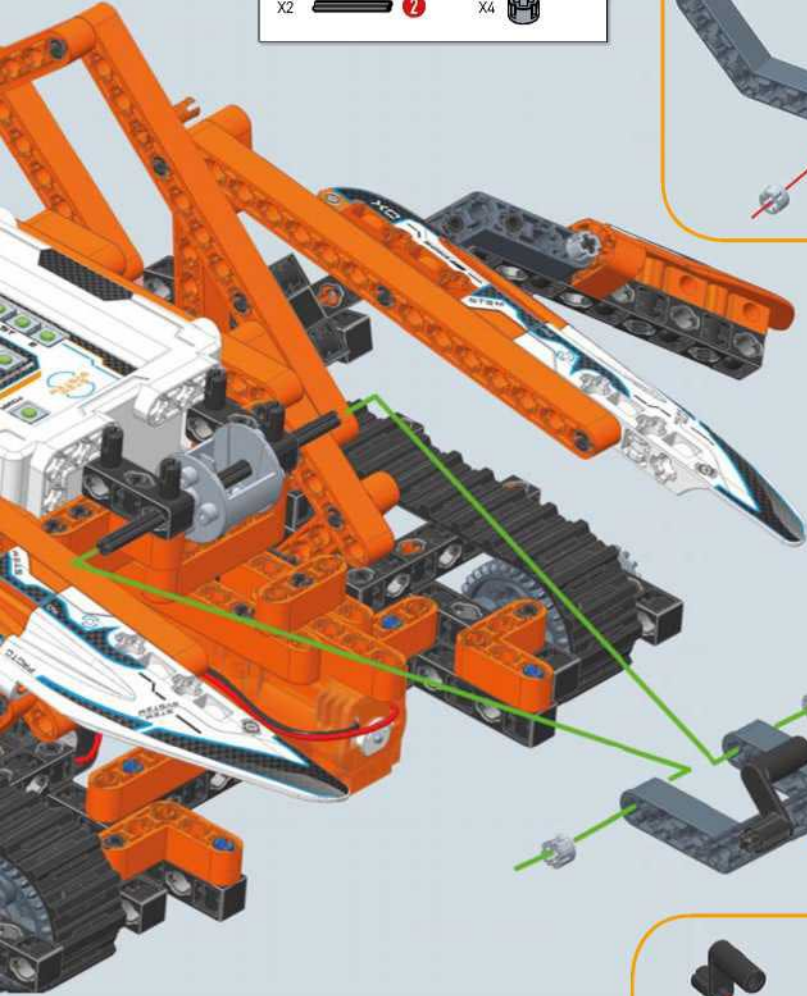
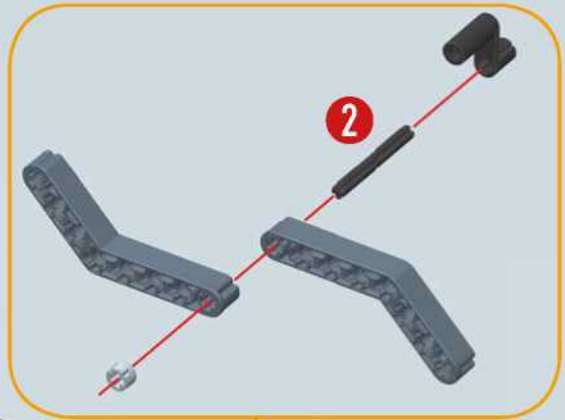
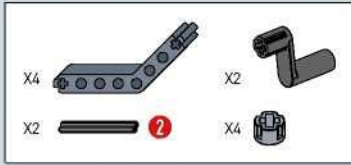

1:1

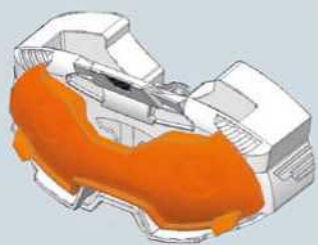

Změňte orientaci hledi na masce.

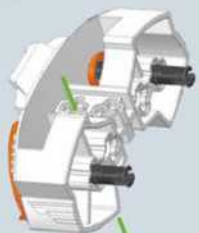

X1



X1

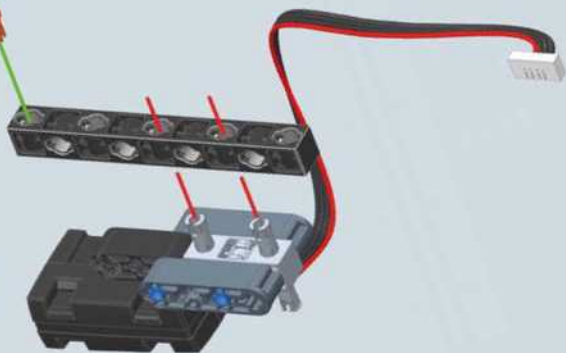

4

5



## PŘIPOJENÍ SENZORU K CENTRÁLNÍ JEDNOTCE

Připojte IR senzor k portu IR1 centrální jednotky.



**IR1**

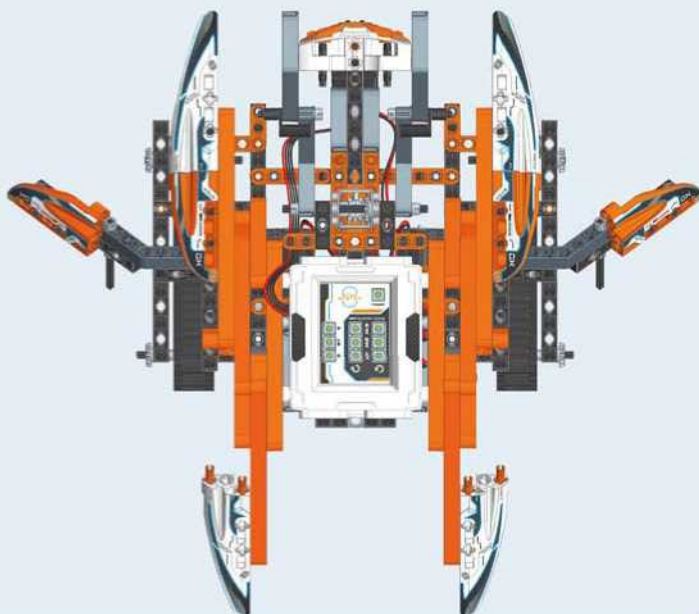

## DOKONČENÝ MODEL

