

coding
lab → → ↑

RoboMaker[®]

výuková laboratoř robotiky

pro

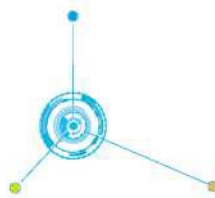

X3-SUMOBOT



Clementoni Polska Sp. z o.o.
ul. Maszynowa 32,
80-298 Gdansk, Polska
Tel.: +48 58 3432882
poland@clementoni.com

PRODUCENT: Clementoni S.p.A.
Zona Industriale Fontenoce s.n.c.
62019 Recanati (MC) - Italy Tel.:
+39 071 75811

www.clementoni.com

 advanced

Přečtěte si pokyny a uschovejte si je pro případnou potřebu

 **Clementoni**[®]

Sumo

Montáž

1

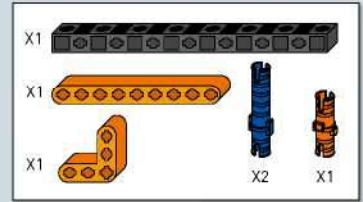
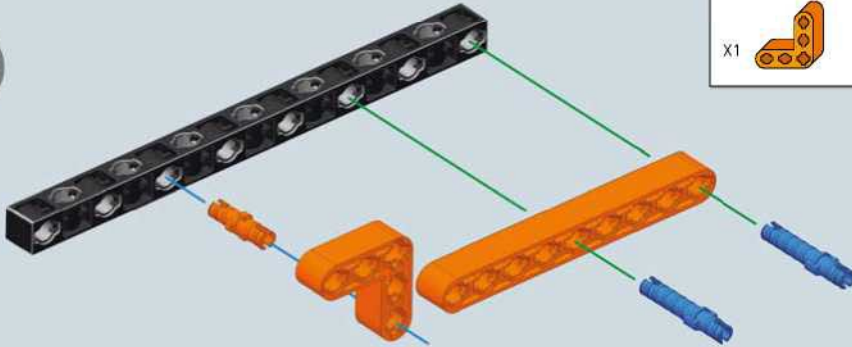

2

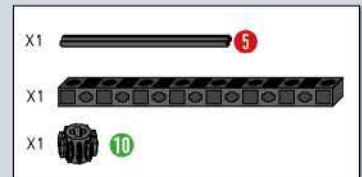
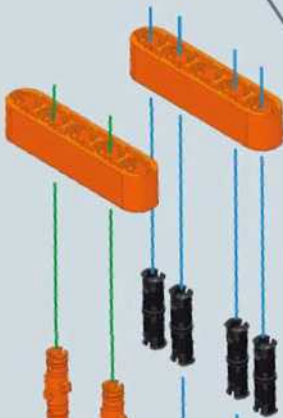
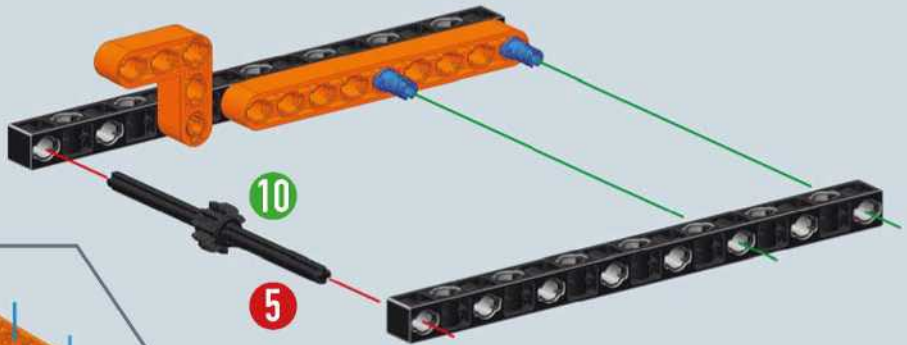

3

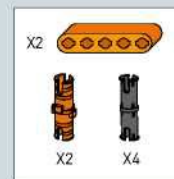

2



4

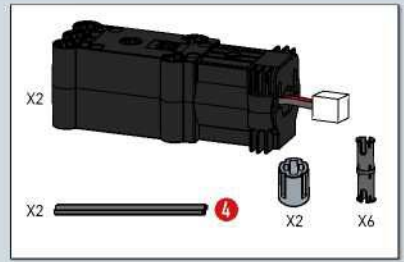

4

1:1

4

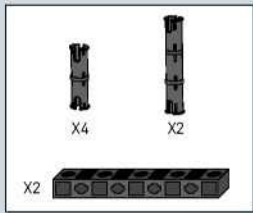

5

3



6

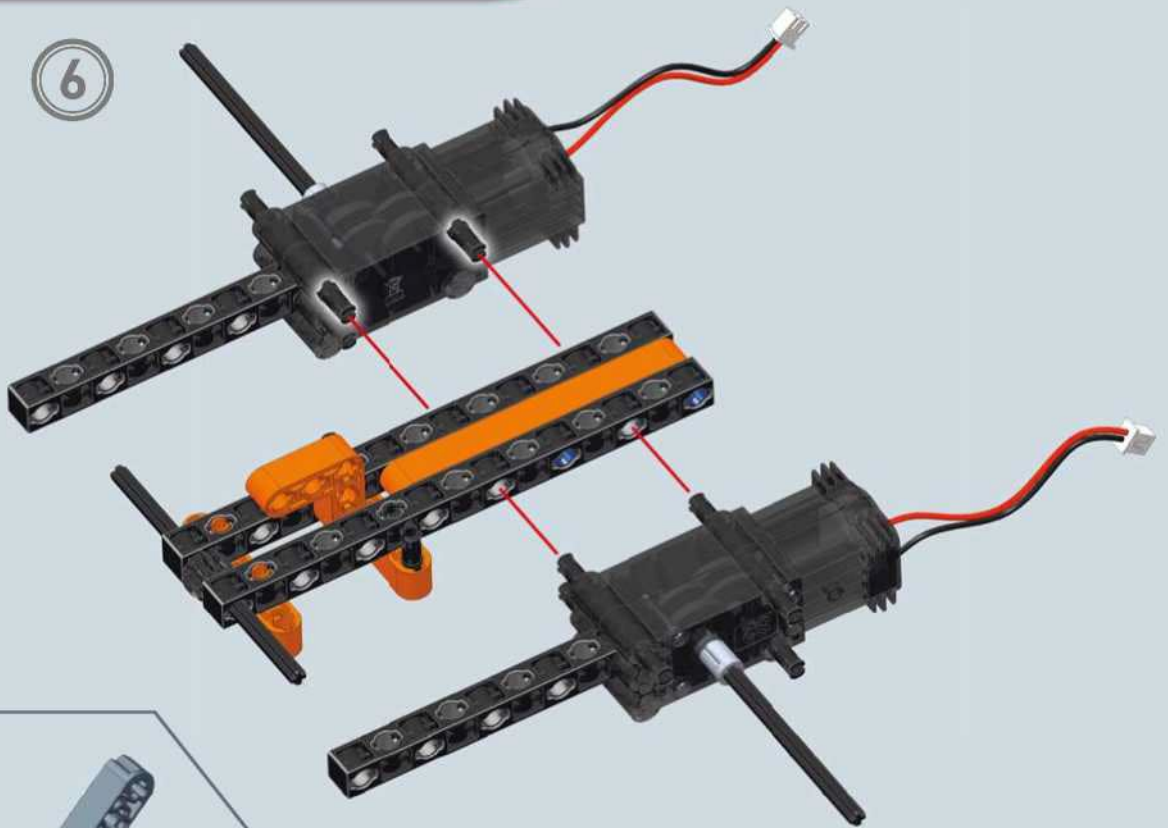

7

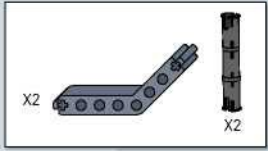
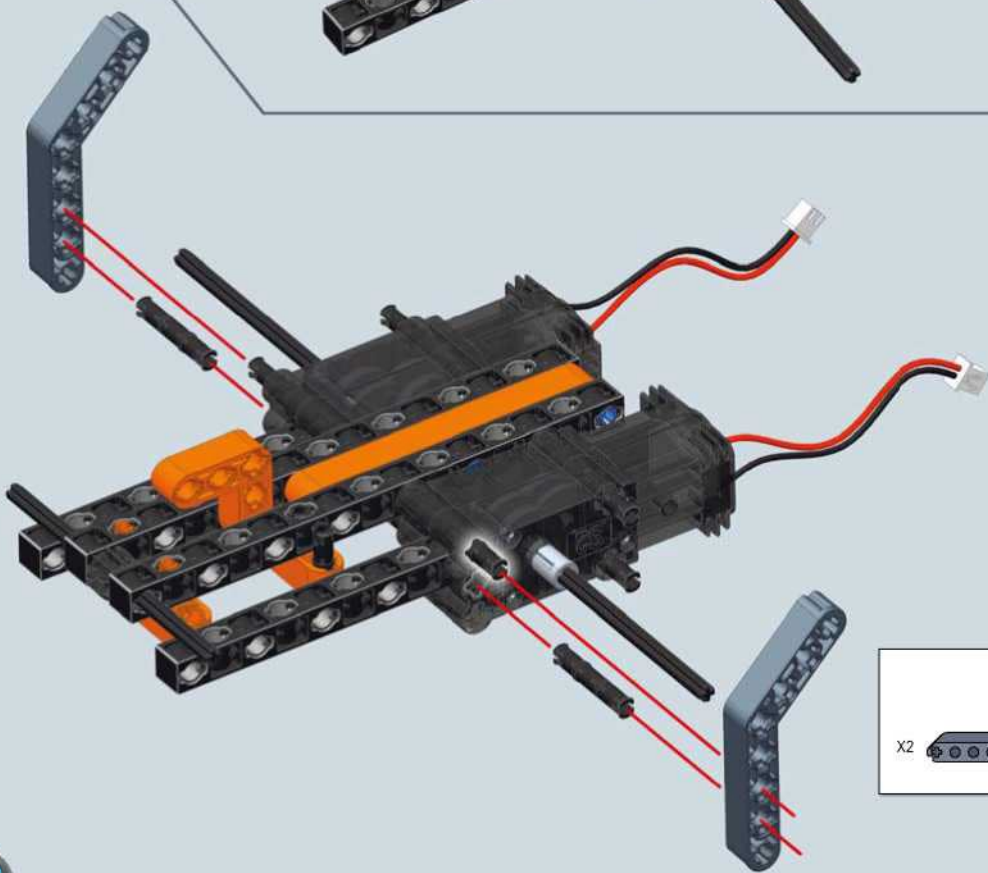

4

8

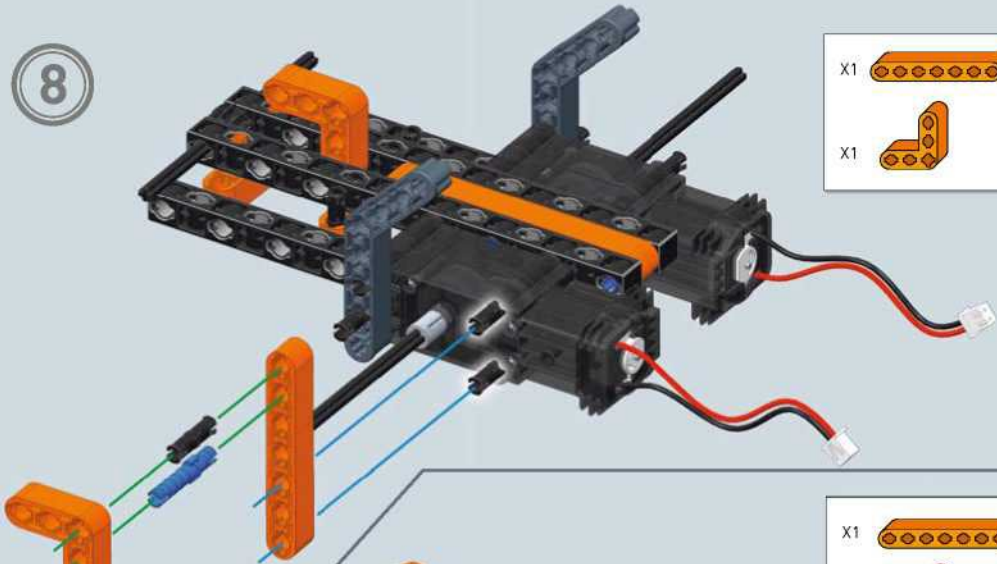
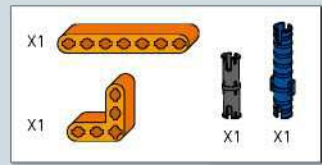

9

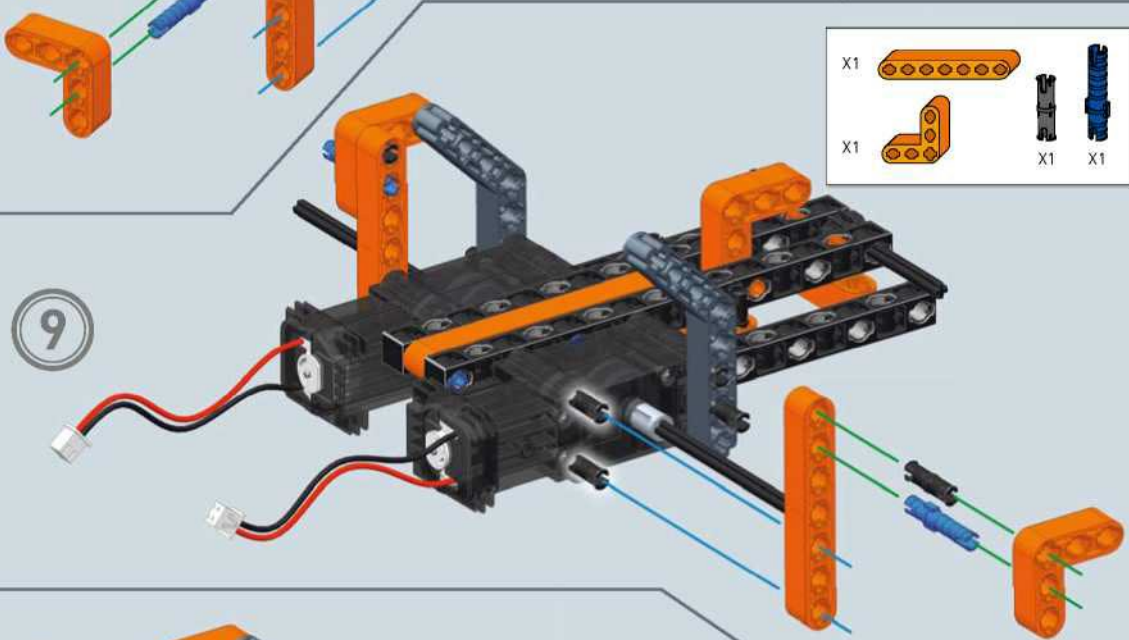
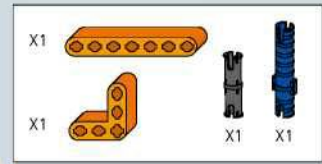

10

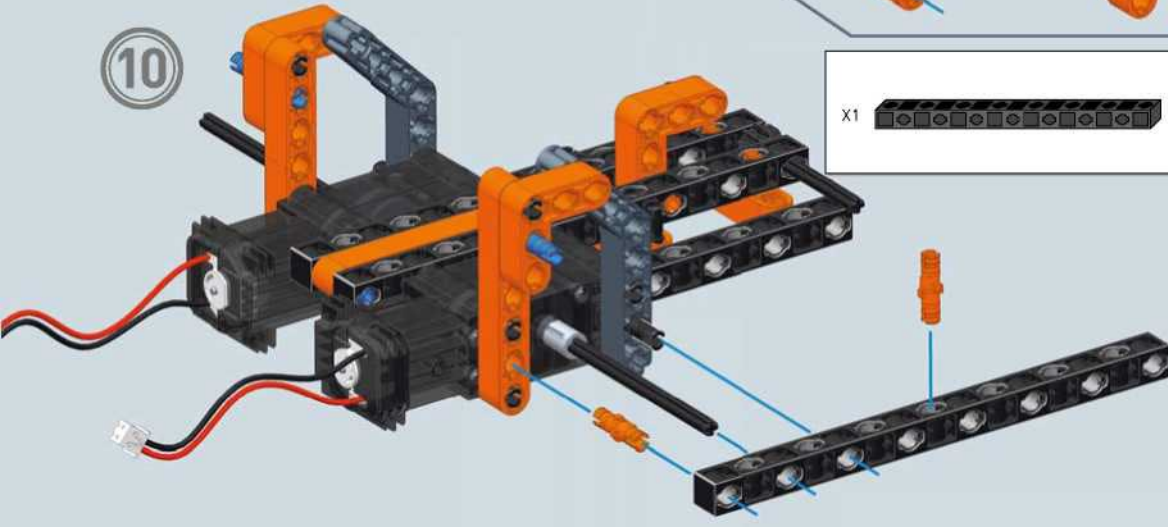

12

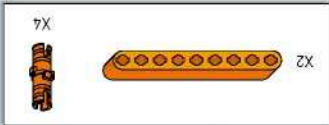
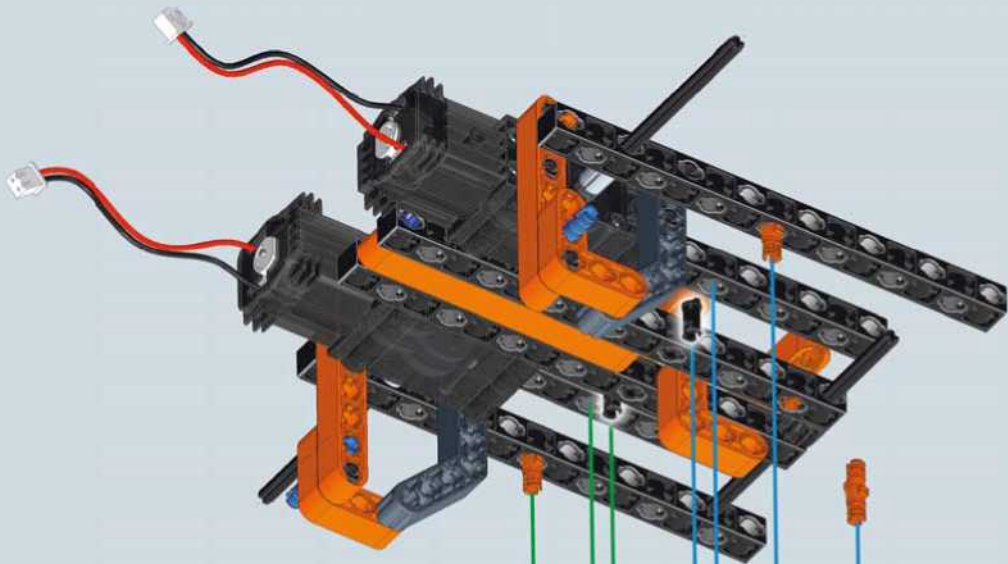

11

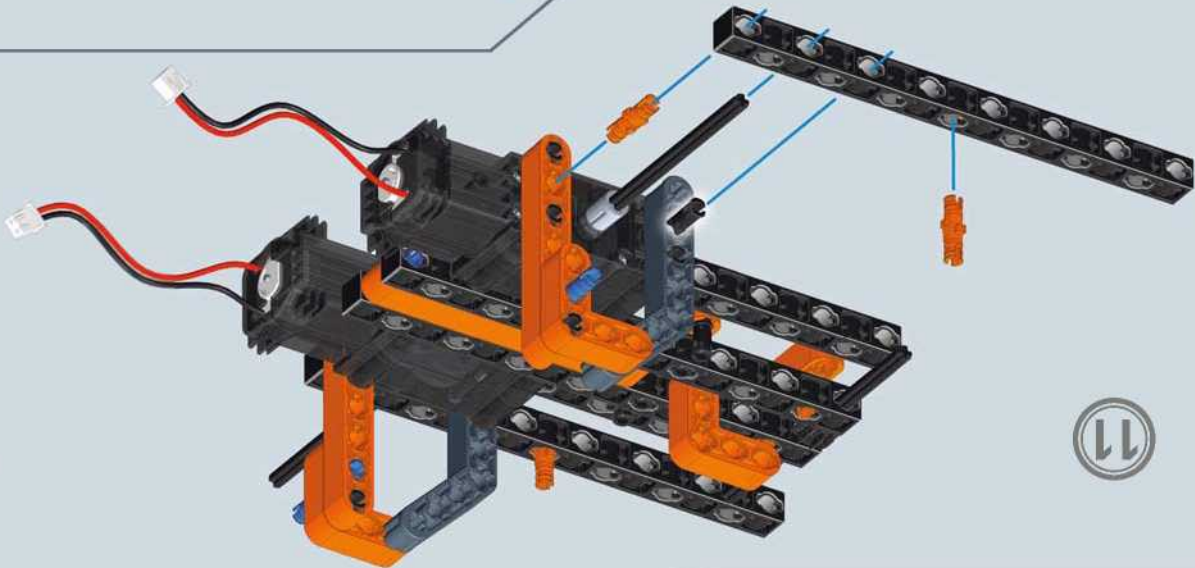

13

3

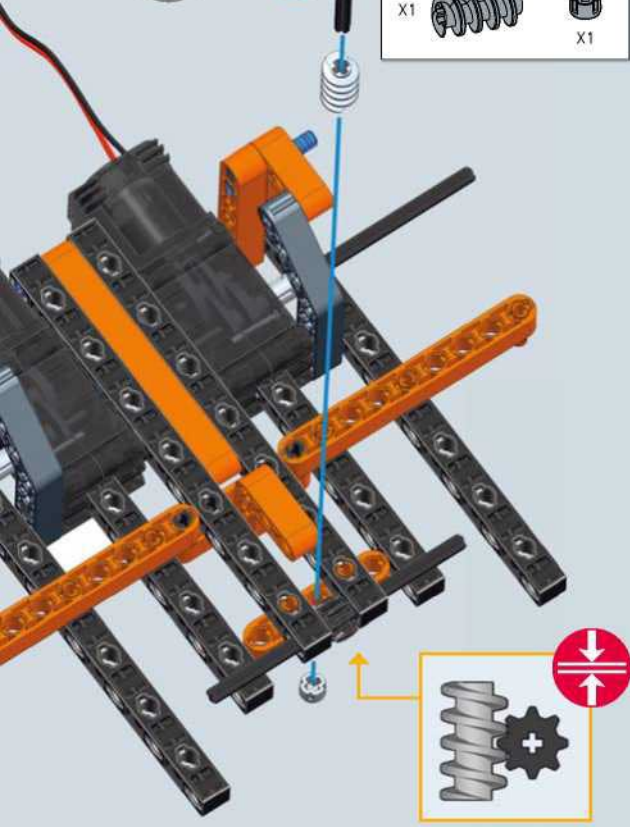
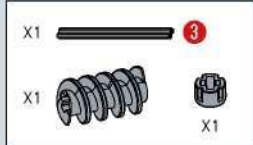

14

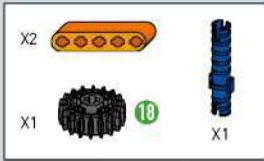
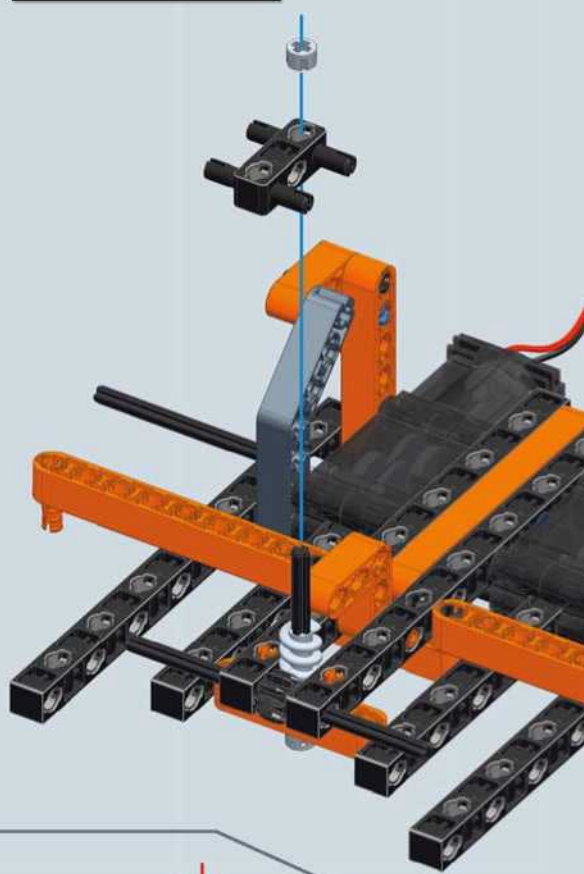
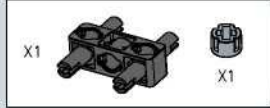

15

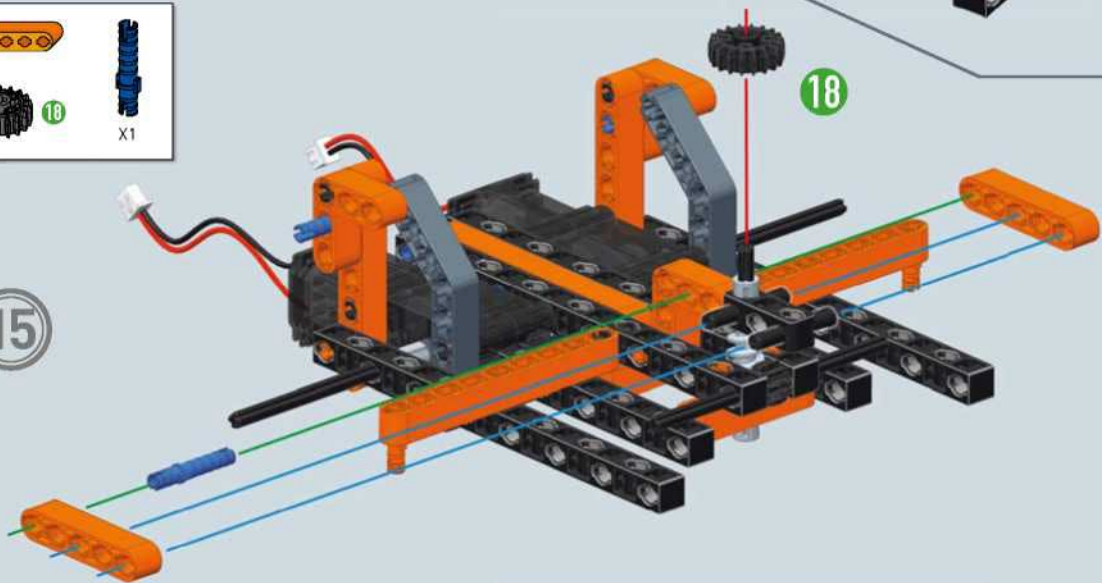

7



16

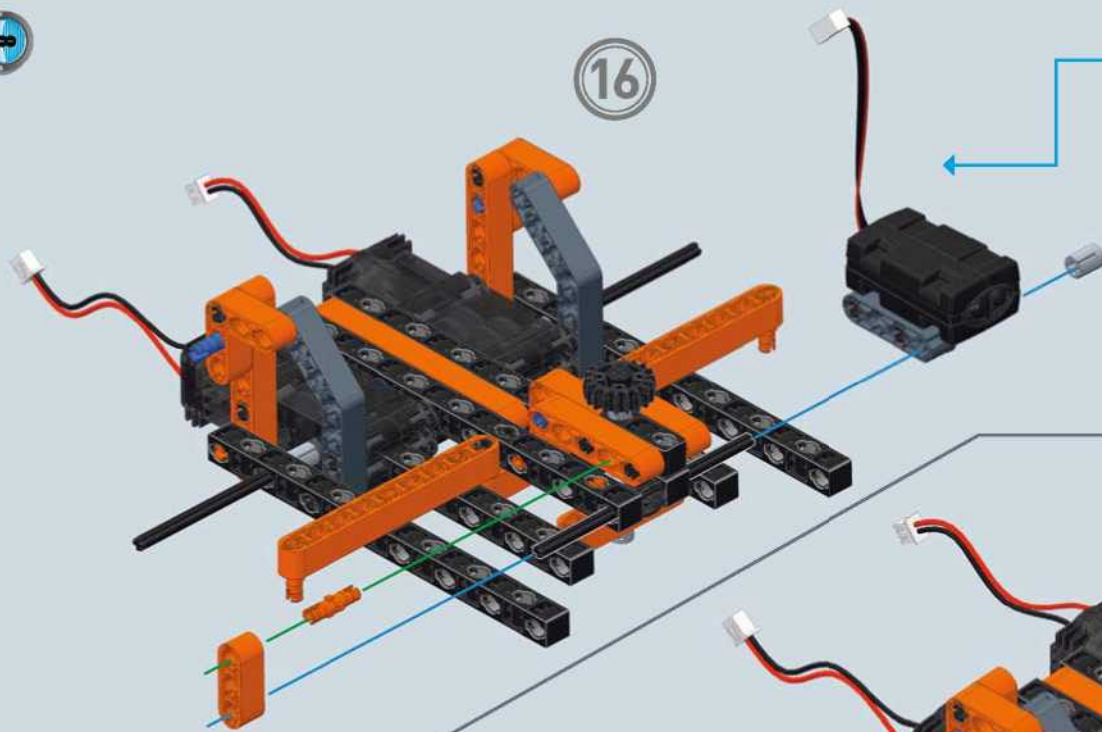

17

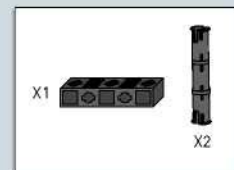
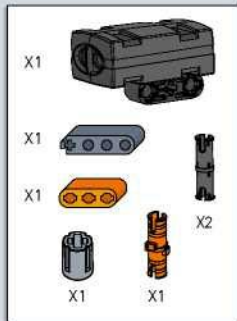
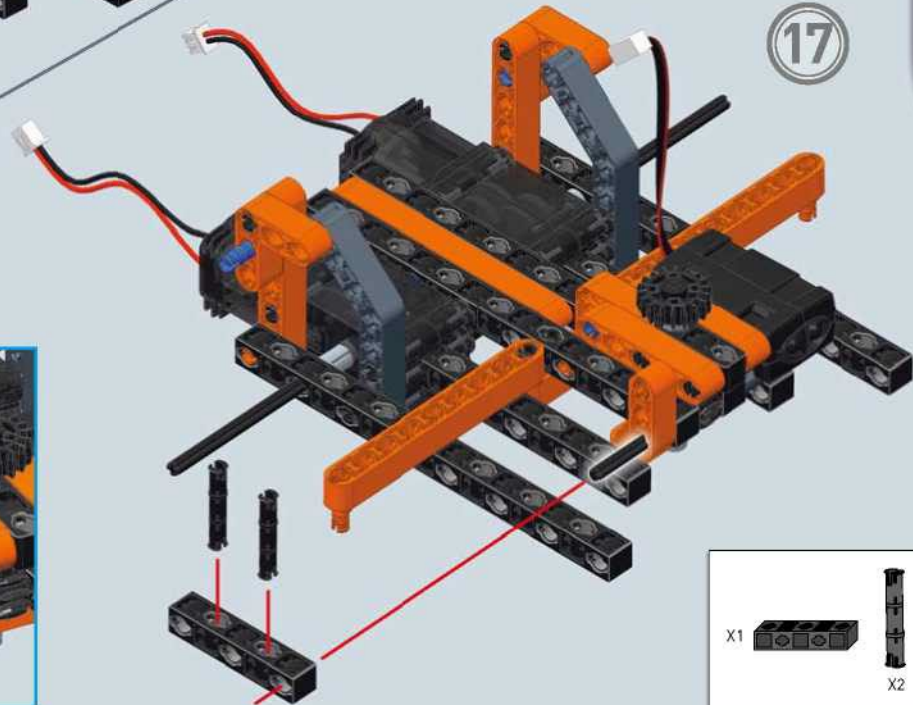

6

20

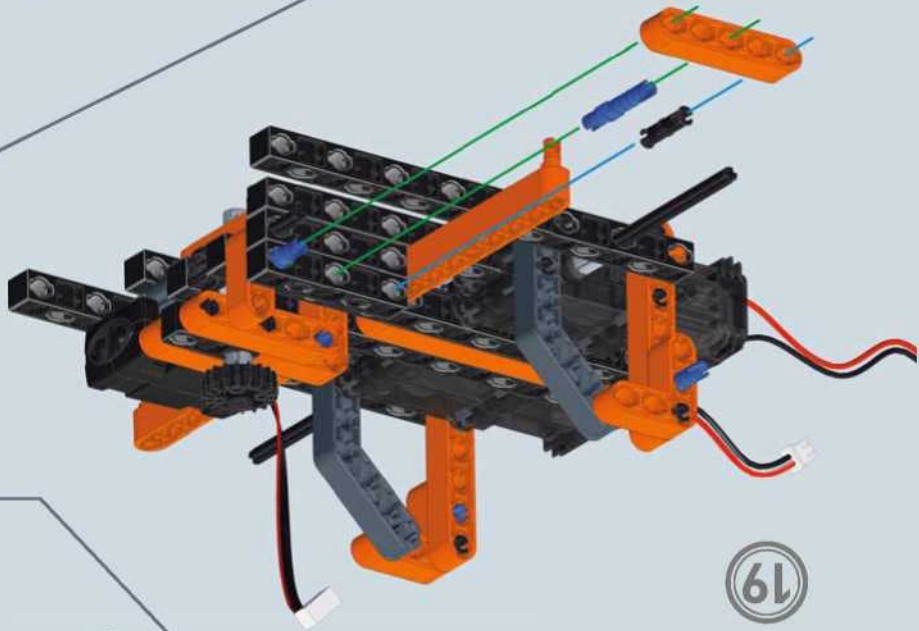
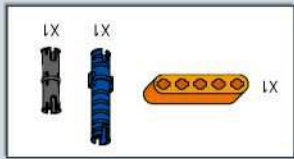
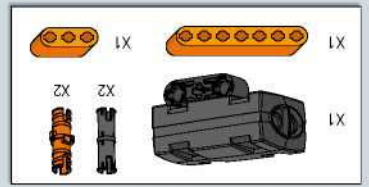
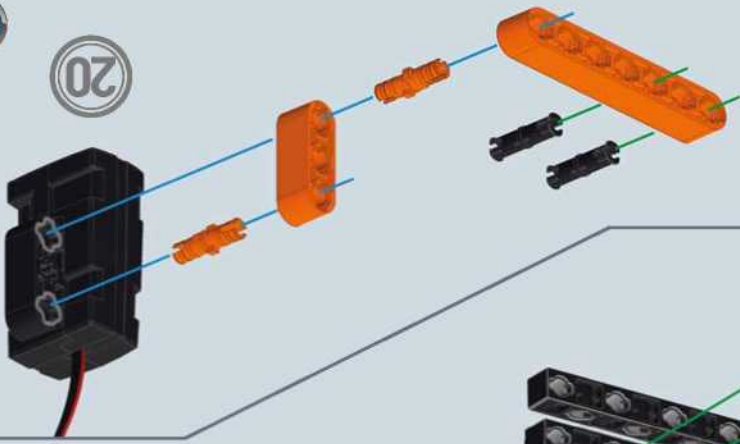

19

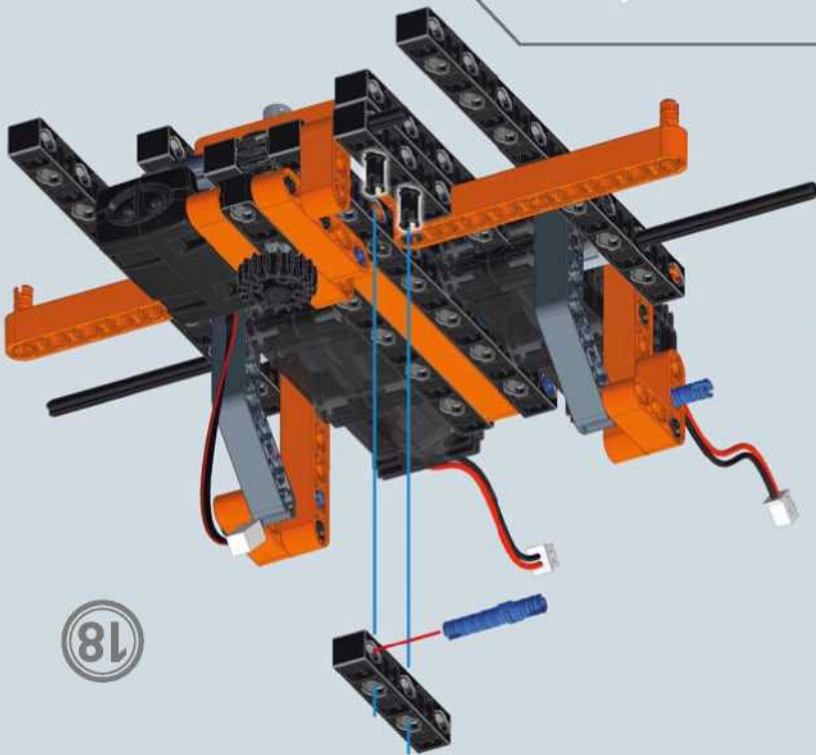

18

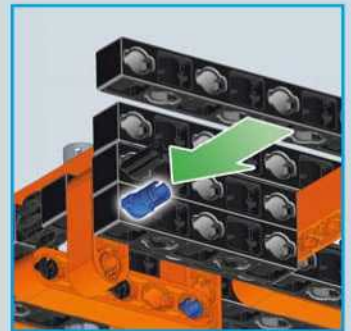
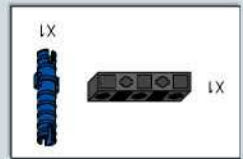

21

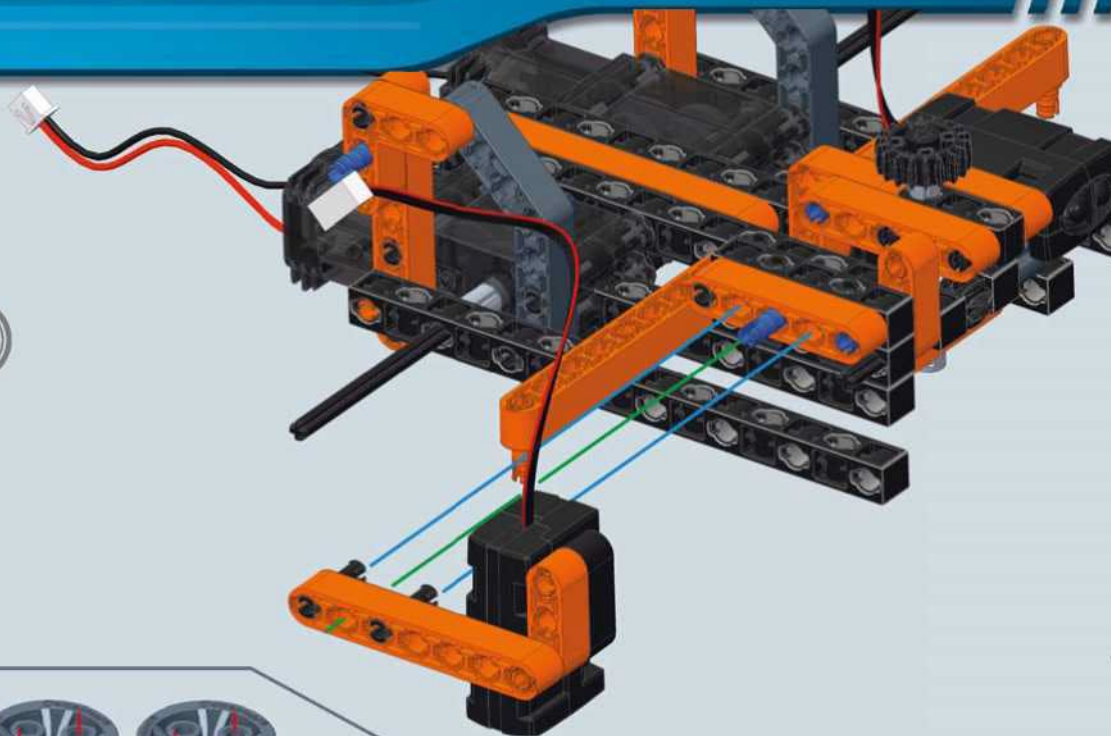

22

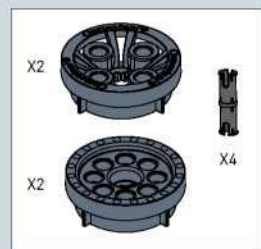
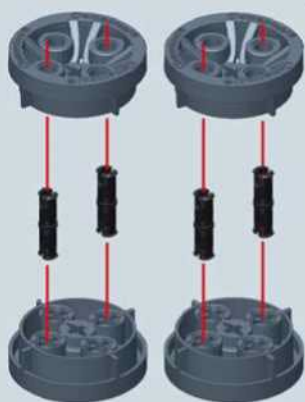

23



24

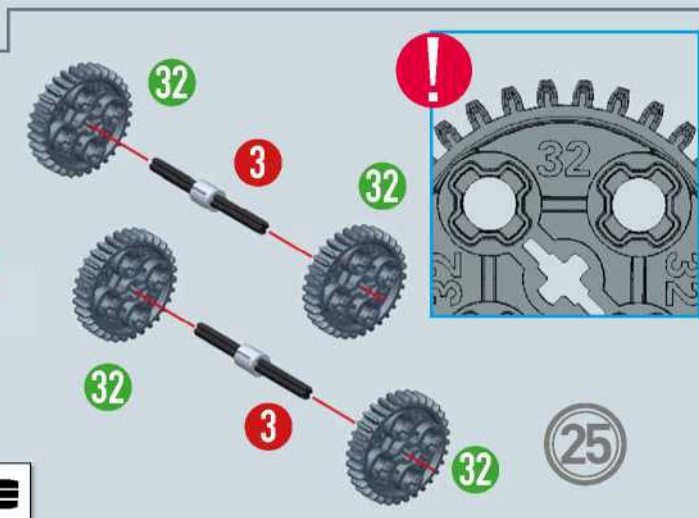
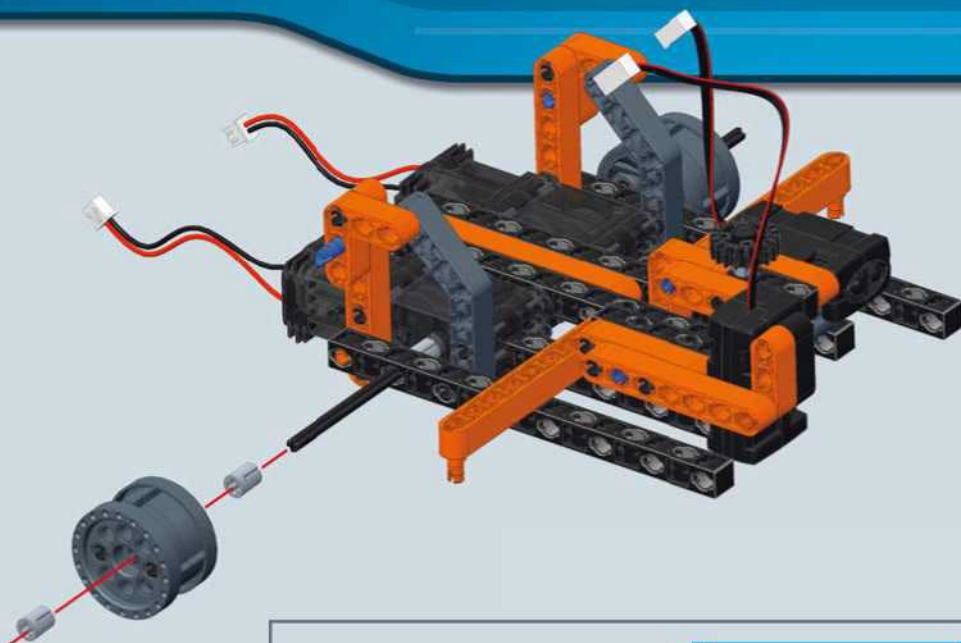

25

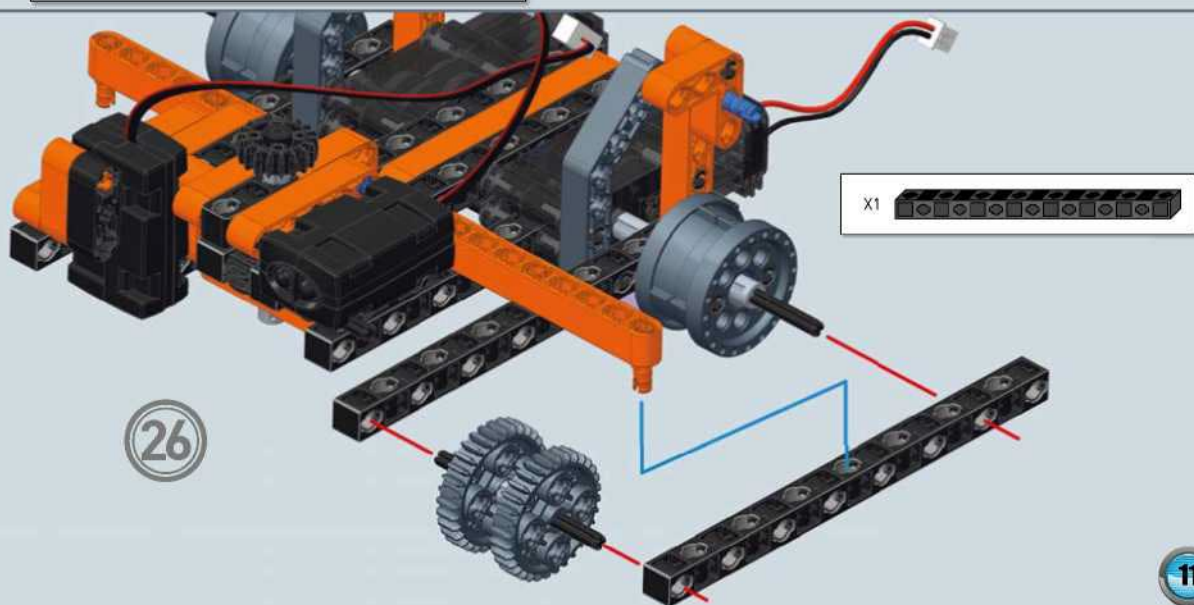



26

27

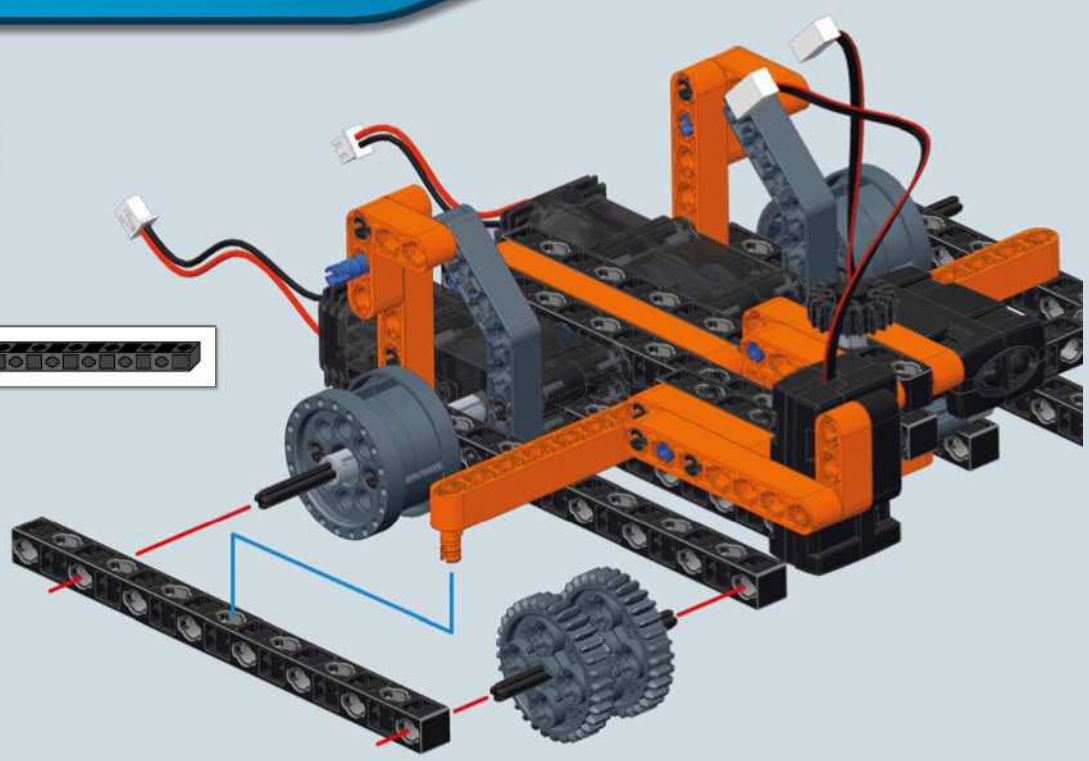
X1 



28

X2  X4 

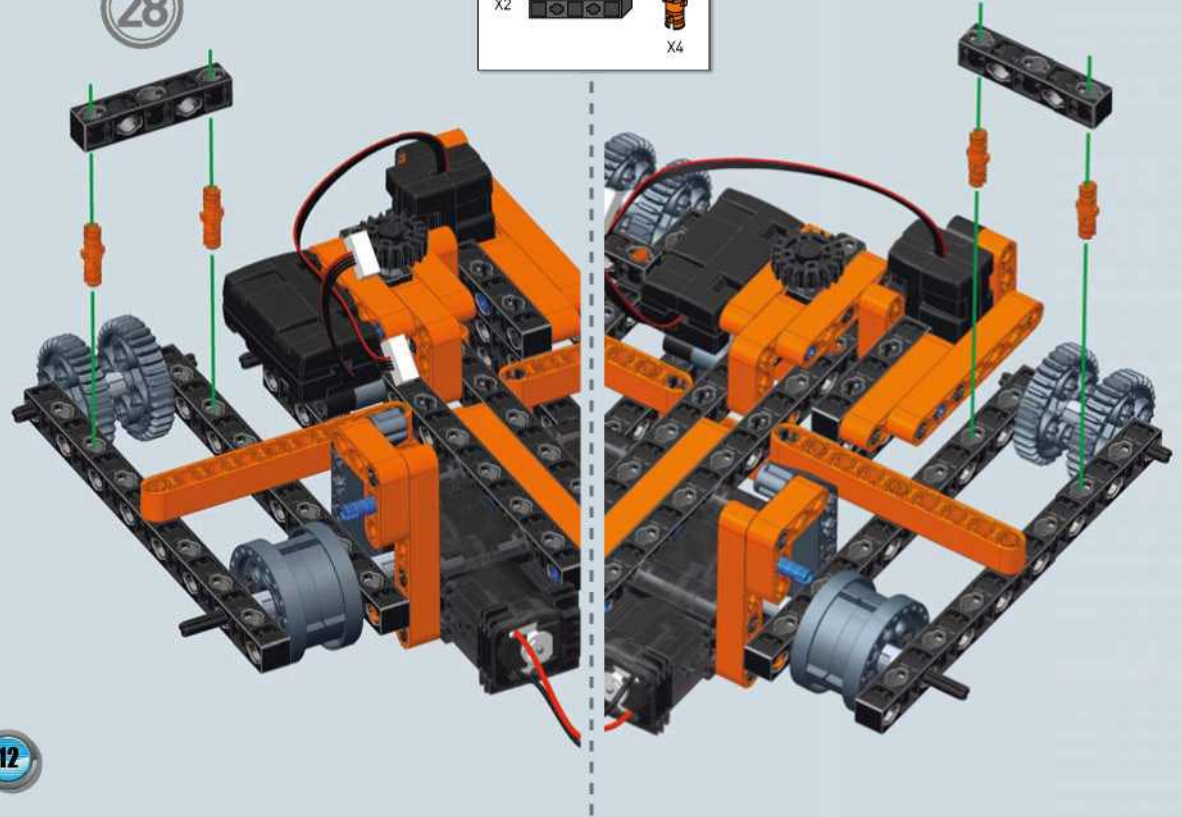

29

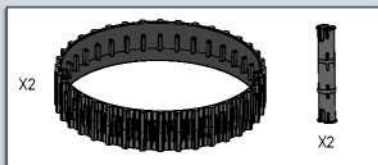
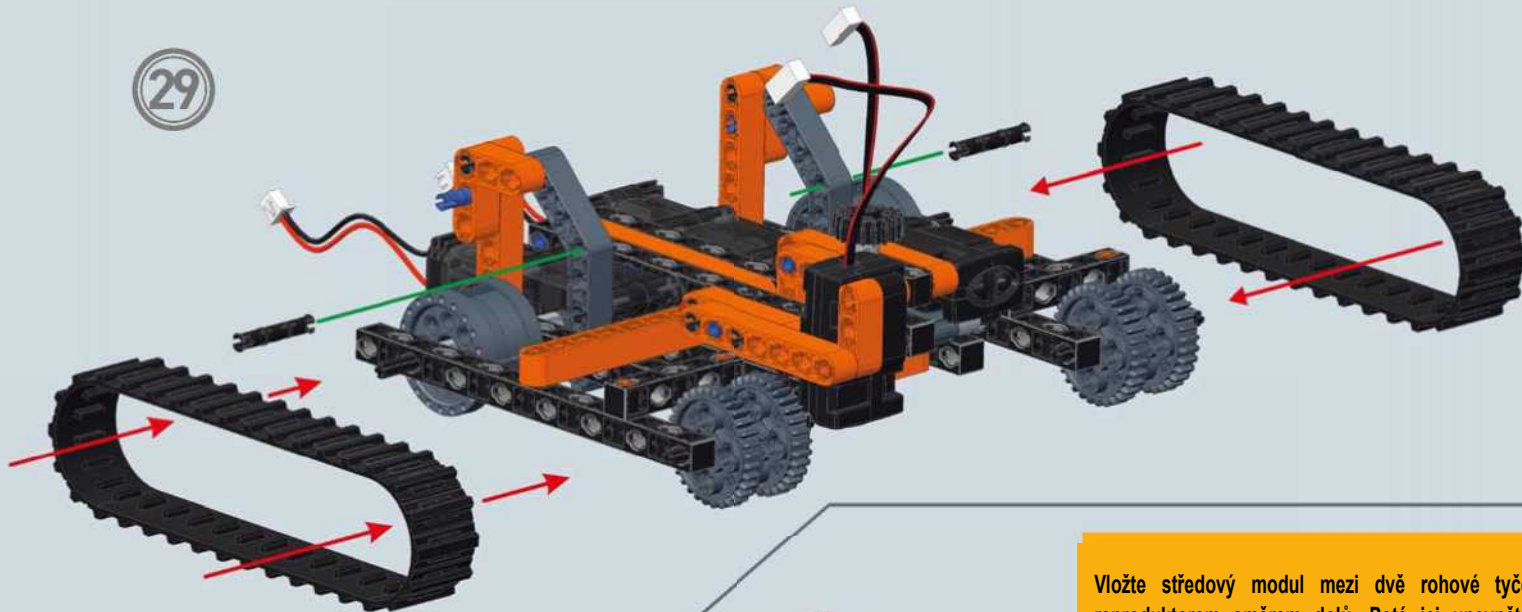

Vložte středový modul mezi dvě rohové tyče reproduktorem směrem dolů. Poté jej upevněte pomocí dlouhého černého nýtu a tyče (2.)

30

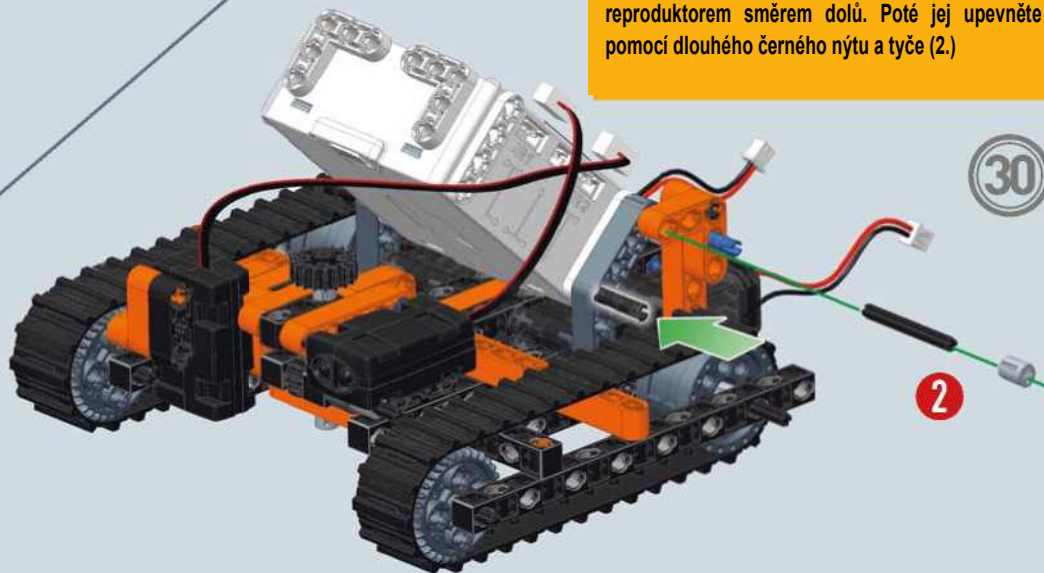



31

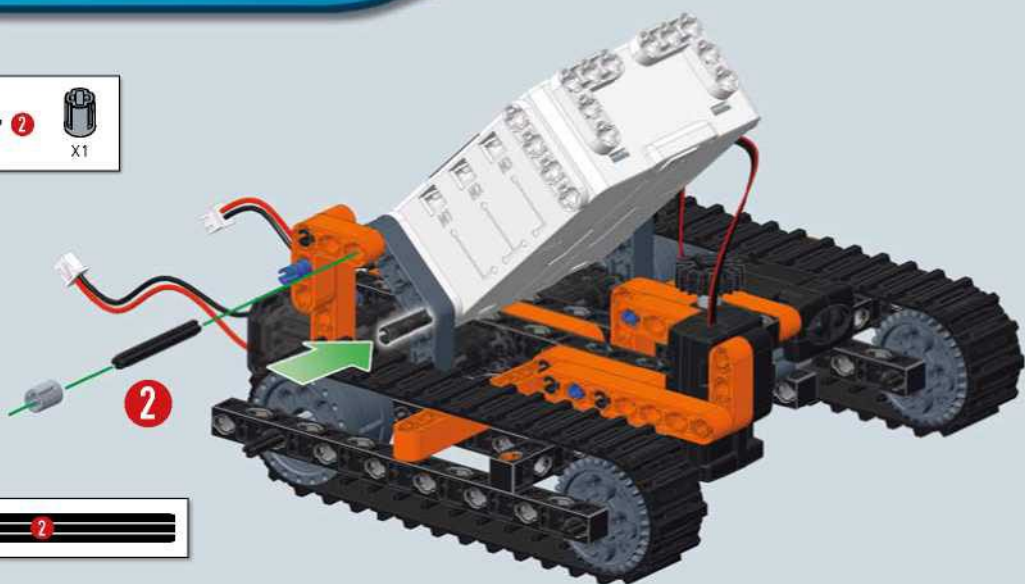

PŘIPOJENÍ MOTORŮ K MODULU CENTRAL

Umístěte model podle obrázku
a připojte motor vlevo k portu
M1 a motor vpravo k portu M2.

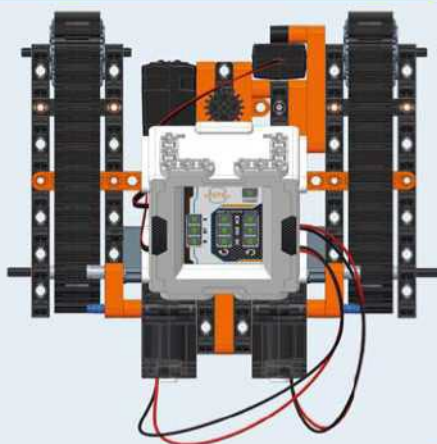
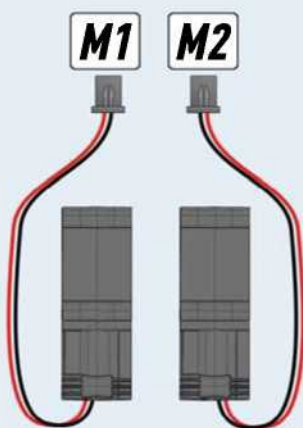

PŘIPOJENÍ SENZORŮ K MODULU CENTRAL

Umístěte model podle obrázku
a připojte IR senzor vlevo k
portu IR1 a IR senzor vpravo k
portu IR2.

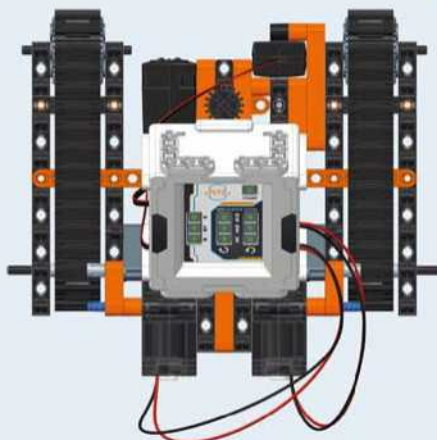
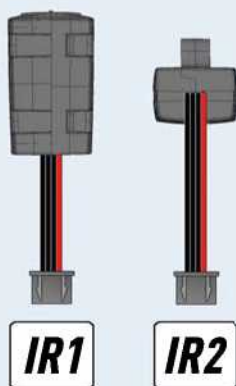

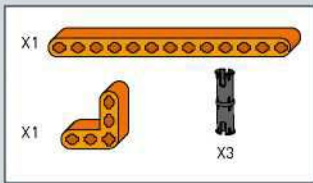

32

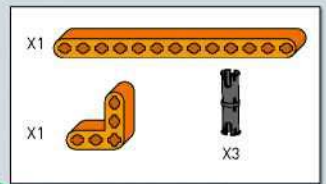
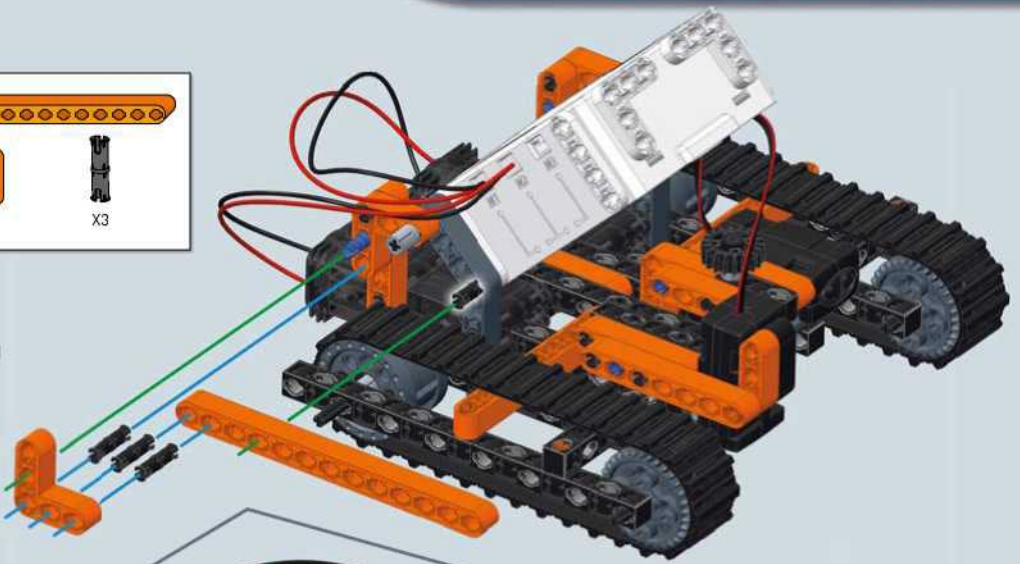

33

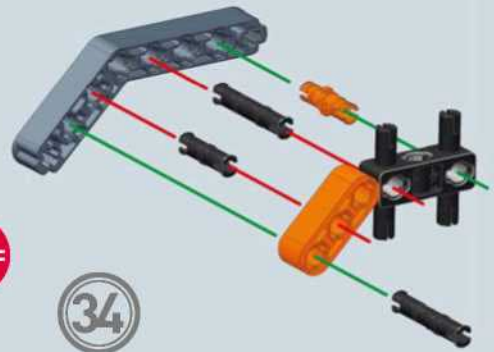
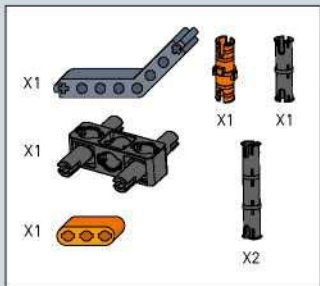
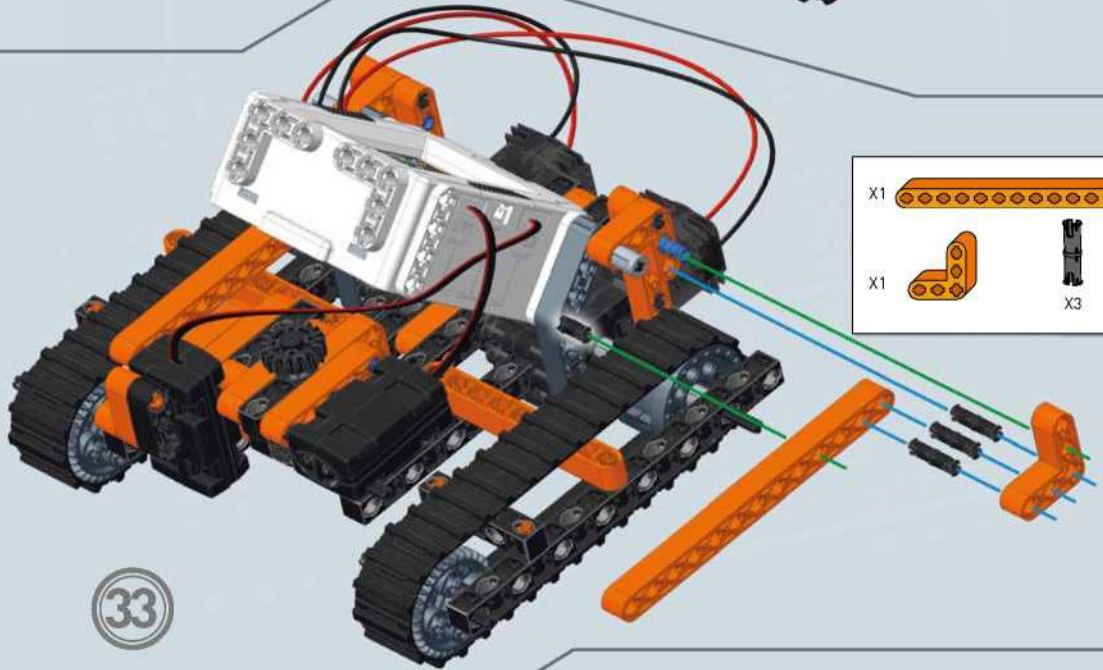

34

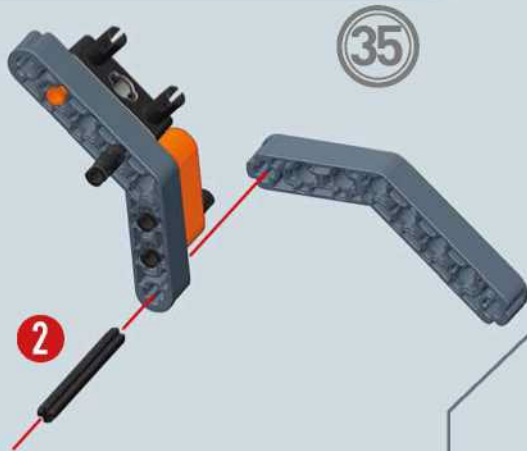

35

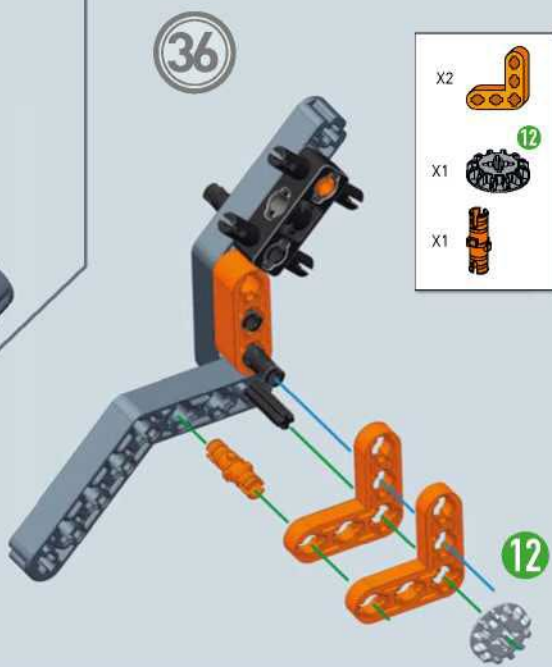
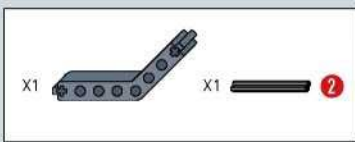

36

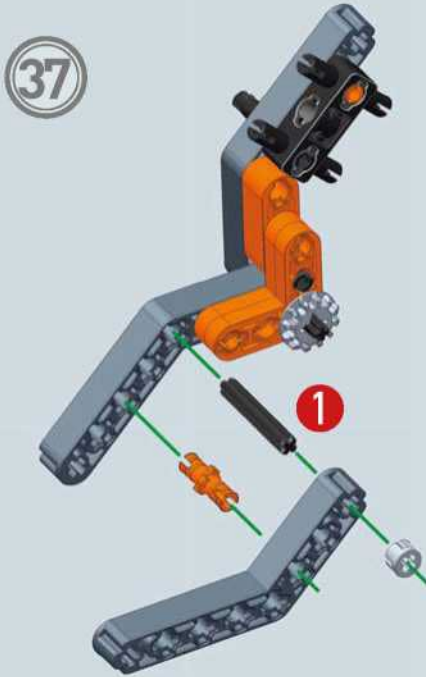

37

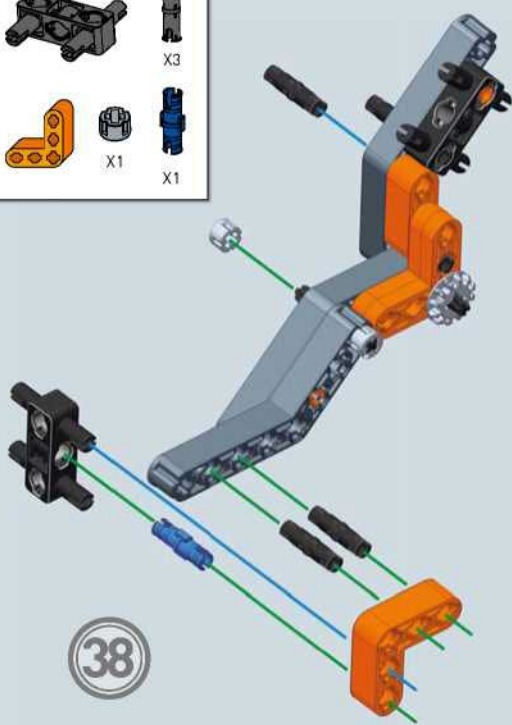
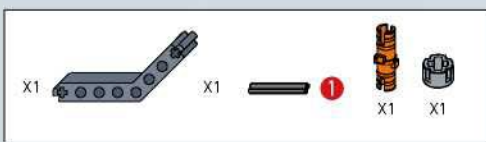
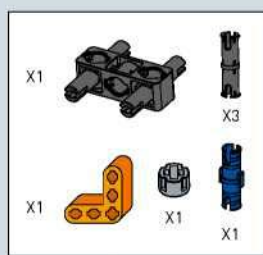

38



44

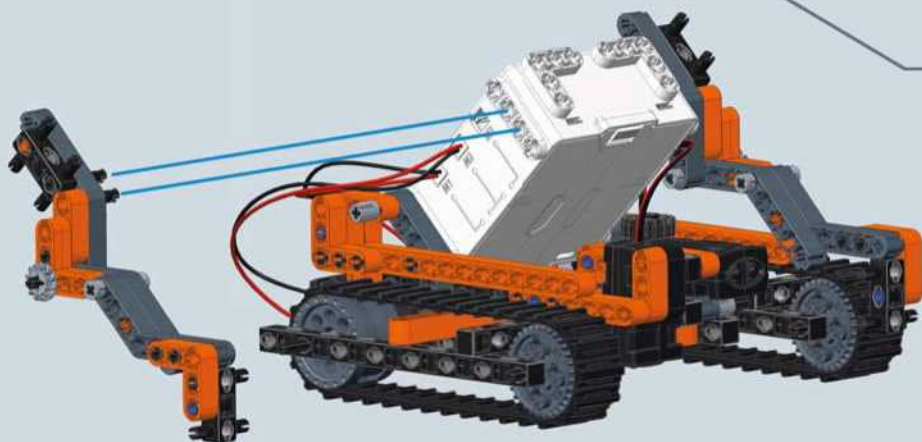
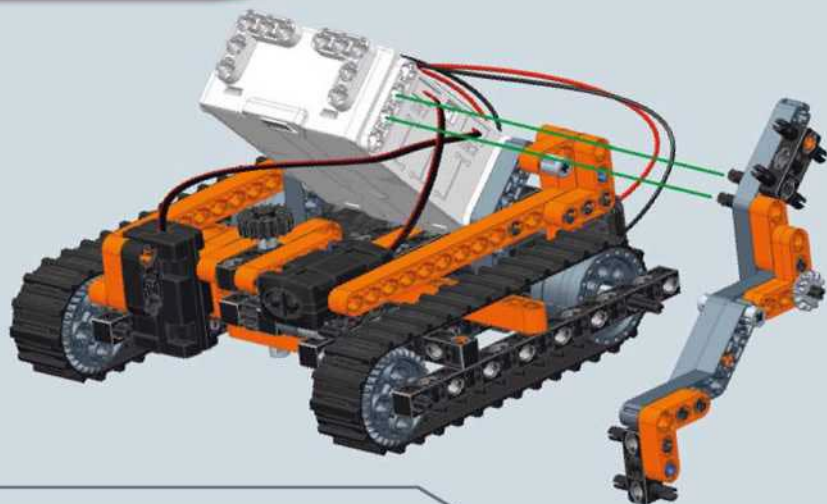

45

46

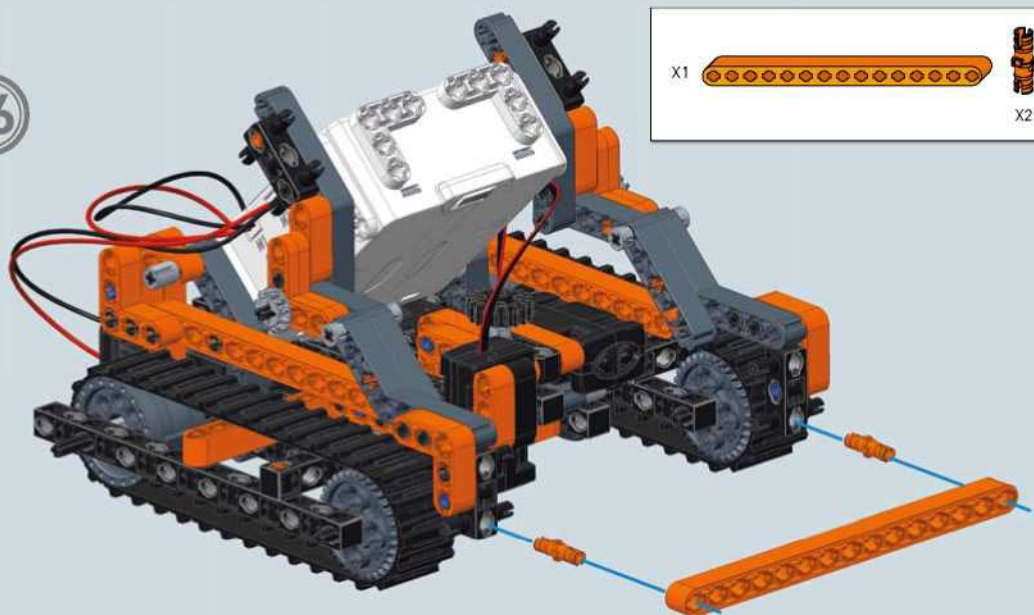

X1

X2

- X2  12
- X1 

47

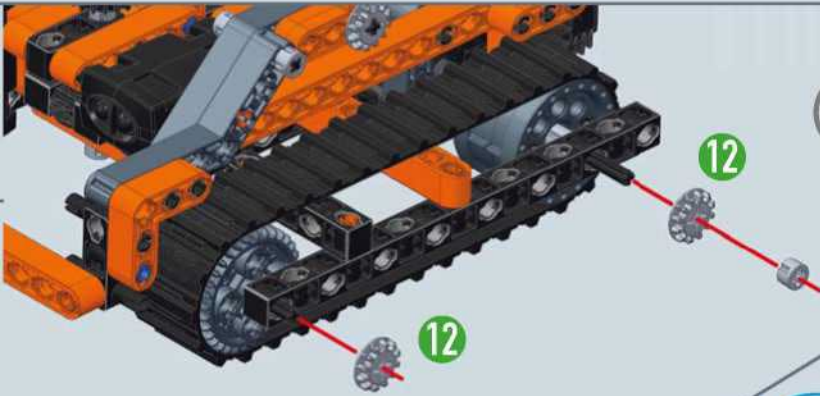
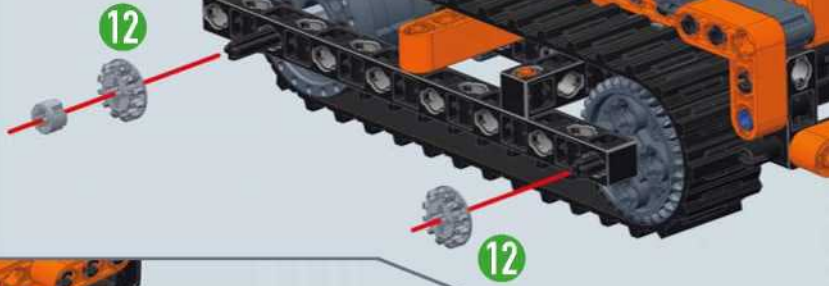





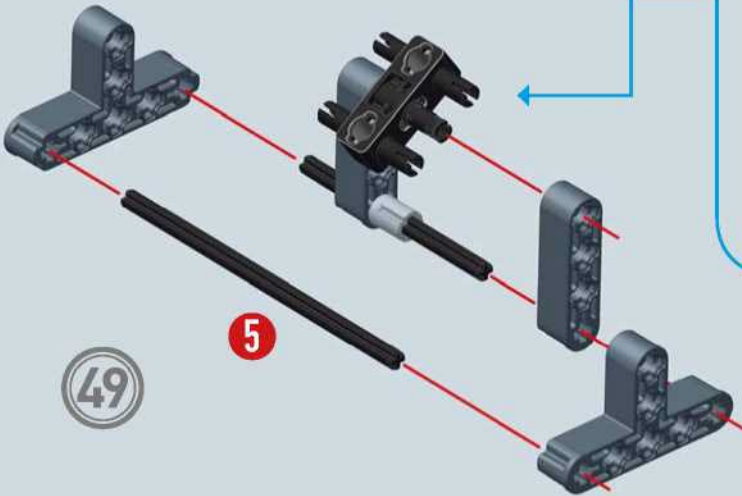

48

- X2  12
- X1 



49

- X1  5
- X1  3
- X2 
- X2 
- X1 
- X1 
- X1 



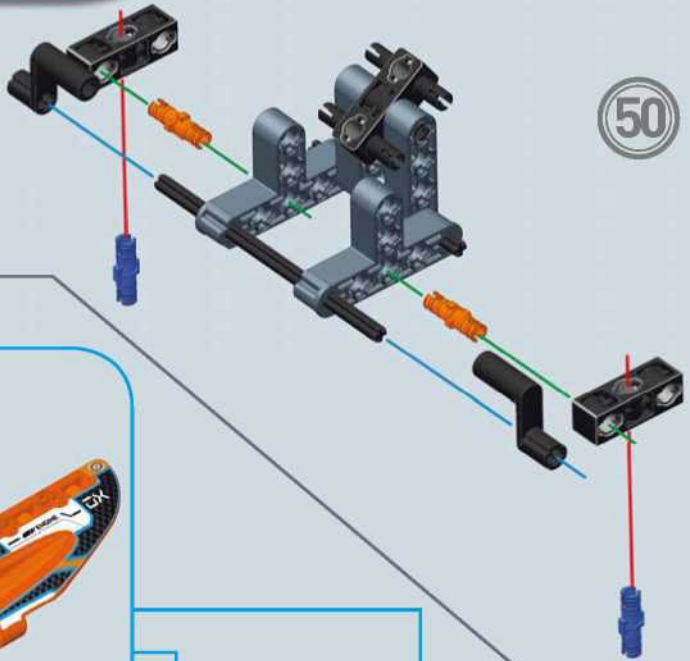
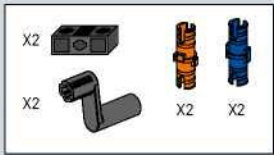

50

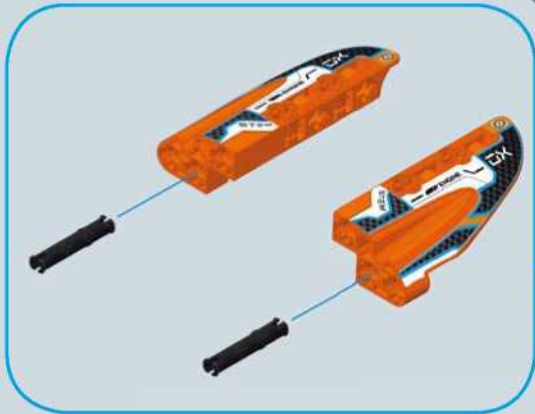

51

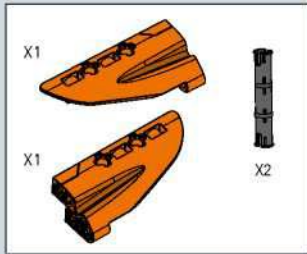

52

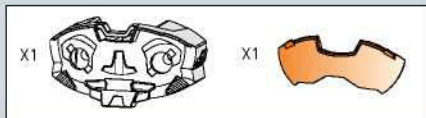
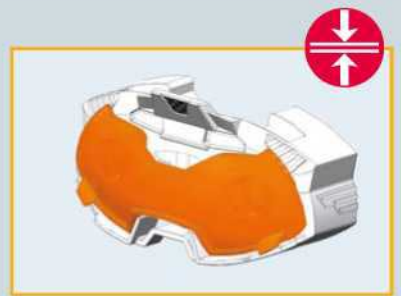
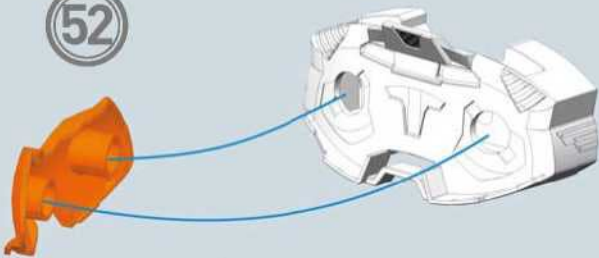

53

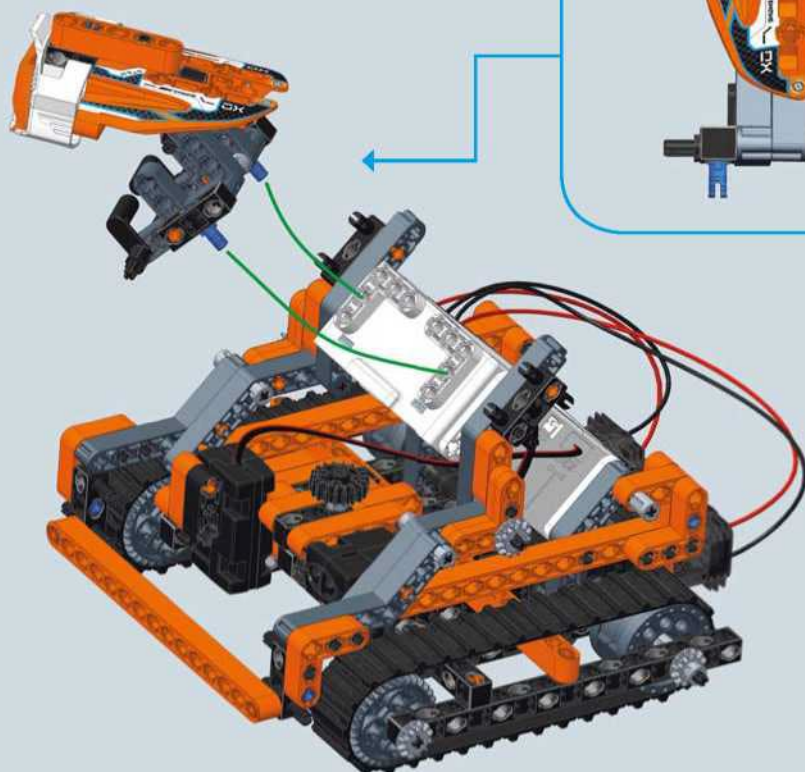
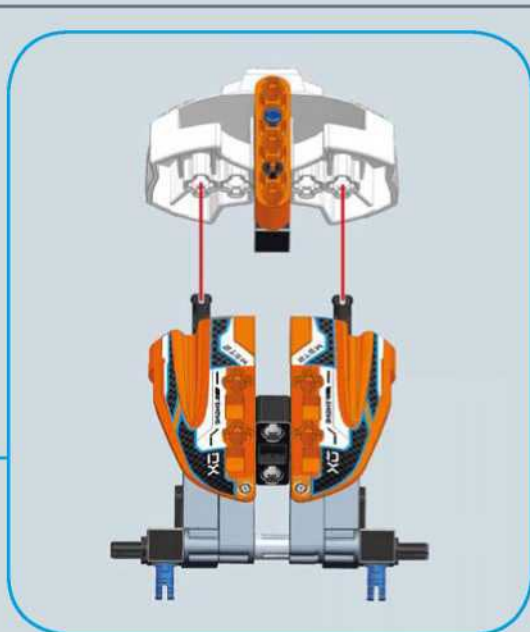
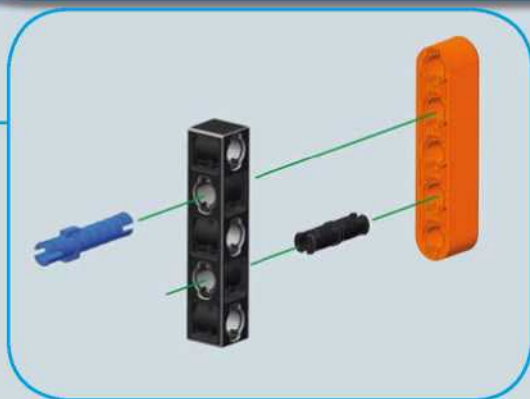
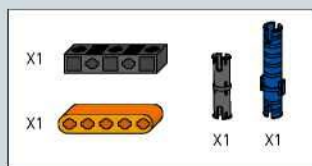
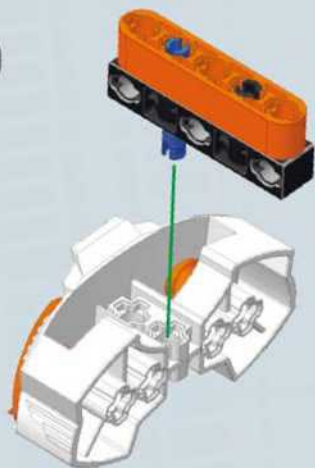

54

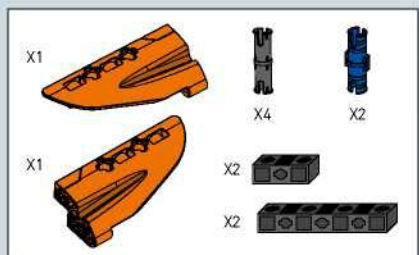
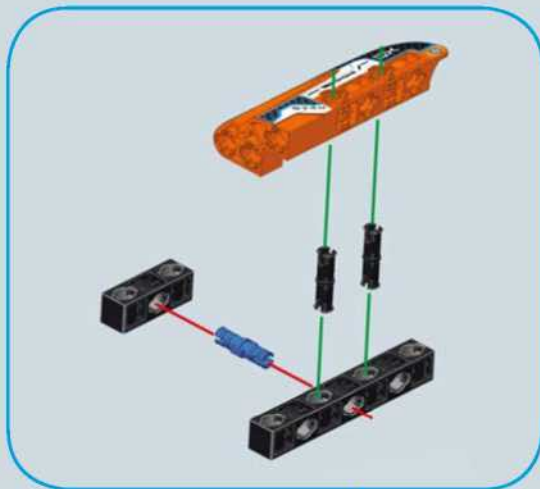
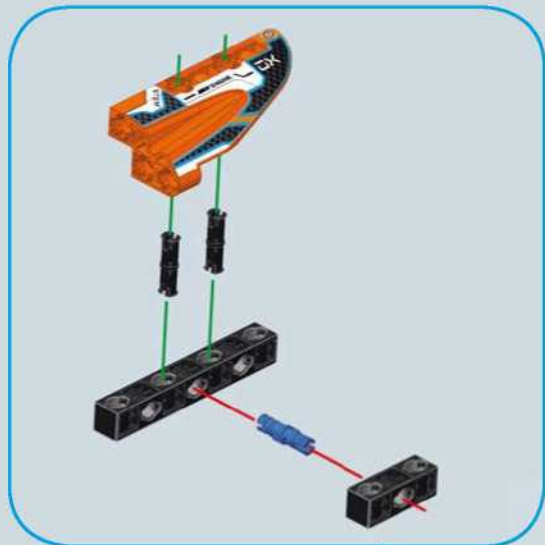

DOKONČENÝ MODEL



Ujistěte se, že jsou IR senzory orientovány podle obrázku: senzor vpravo směřuje dolů a senzor vlevo dopředu. Otáčením 18zubého kolečka můžete změnit polohu snímače vlevo.

Montaż

ZMĚNA ORIENTACE IR SENZORU PRO ÚLOHU SLEDOVÁNÍ LINIE

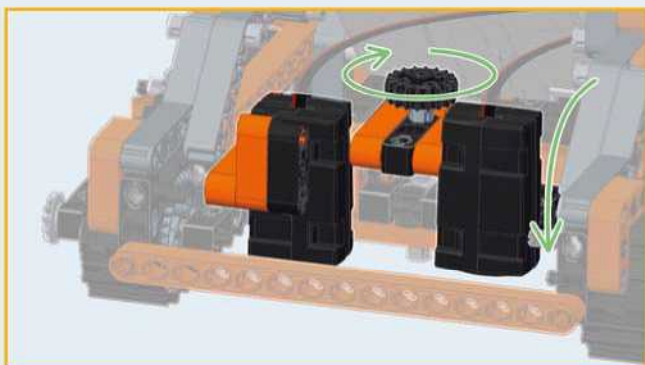

Vycházejte z hotového modelu z úlohy 5 - Sumo a pomocí 18zubého kolečka přeměrujte infračervený senzor vlevo: Otáčejte kolečkem tak, aby infračervený snímač směřoval dolů a druhý infračervený snímač doprava.

